



SV•Xchange™ User Manual



Version 1.33
19 May 2016

Revision History

| Revision | Date | Description | Author |
|-----------------|----------------------|-----------------------------|---------------|
| Version 1.2 | 17 June 2013 | Format revision and updates | Jehan Zouak |
| Version 1.3 | 25 March 2014 | Added Technical Drawing | Jehan Zouak |
| Version 1.31 | 19 September 2014 | Updated technical drawing | Jehan Zouak |
| Version 1.32 | 13 April 2016 | Minor updates | Jehan Zouak |
| Version 1.33 | 19 May 2016 | Minor updates | Jehan Zouak |

Table of Contents

| | |
|--|----|
| General Description of the Sensor | 2 |
| Where Do I Start? | 3 |
| Shipping and Receiving | 4 |
| Receiving the Sensor..... | 4 |
| Returning a Sensor to the Factory | 5 |
| Using the Sensor..... | 5 |
| Pressure Ratings | 5 |
| Installing the Sensor | 5 |
| Removing the Sensor | 6 |
| Pre-Deployment Procedures..... | 6 |
| Post-Deployment Procedures | 6 |
| Maintaining the Sensor | 7 |
| Periodic Maintenance | 7 |
| Inspecting and Replacing the O-ring..... | 8 |
| Communications | 9 |
| SV•Xchange Commands | 9 |
| Support | 10 |
| Troubleshooting | 10 |
| Contact AML Oceanographic..... | 11 |
| Technical Specifications..... | 12 |
| Ordering Codes..... | 12 |
| Warranty | 13 |
| Technical Overview Drawings | 14 |

General Description of the Sensor

AML Oceanographic's SV•Xchange™ sensor is the industry's only field-swappable time-of-flight sound velocity sensor.

SV•Xchange sensors store all pertinent manufacturing and calibration data internally. This allows the sensor to be swapped between any SV•Xchange enabled instruments without manually updating the calibration coefficients. Calibration sheets can be printed on demand by any instrument connected to the SeaCast software. Re-calibrations only require the sensor, not the instrument, to be shipped to the service centre.

SV•Xchange sensors are engraved at the factory with a unique serial number as shown in the image below.



Where Do I Start?

AML Oceanographic X•Series instruments ship with several manuals on the USB:

- An instrument manual providing an overview on how to use and maintain the instrument;
- A SeaCast manual providing instructions on how to use the software to configure the instrument and review instrument data;
- Xchange™ sensor manuals (CT•Xchange, C•Xchange, SV•Xchange, P•Xchange, T•Xchange, and Tu•Xchange) providing overviews on how to install and maintain each of the Xchange™ sensors;

If you are configuring an instrument for field use or lab testing, begin with the SeaCast manual.

If you are performing instrument maintenance, begin with the instrument manual.

If you are planning to swap an Xchange™ sensor, read the Xchange™ manual corresponding to your sensors.

Shipping and Receiving

Receiving the Sensor

When receiving a new sensor, perform the following steps to ensure the sensor will be ready for deployment when required:

- Inspect the shipping container, looking for signs of damage. Damage to the shipping container could indicate damage to the sensor inside.
- Inspect for damage
 - Check the sensor for cracks or bends
 - Check the connector for corrosion, dirt, and salt deposits
- Connect the sensor to an instrument, ensuring it is installed tightly onto its mount. The blue locking sleeve should be tight, and sitting less than 1mm from the instrument end cap.
- Connect the instrument to a computer using the data cable. Launch SeaCast and verify that the instrument tab is displaying accurate SV•Xchange sensor information. The sensor's serial number and last calibration date should be displayed.

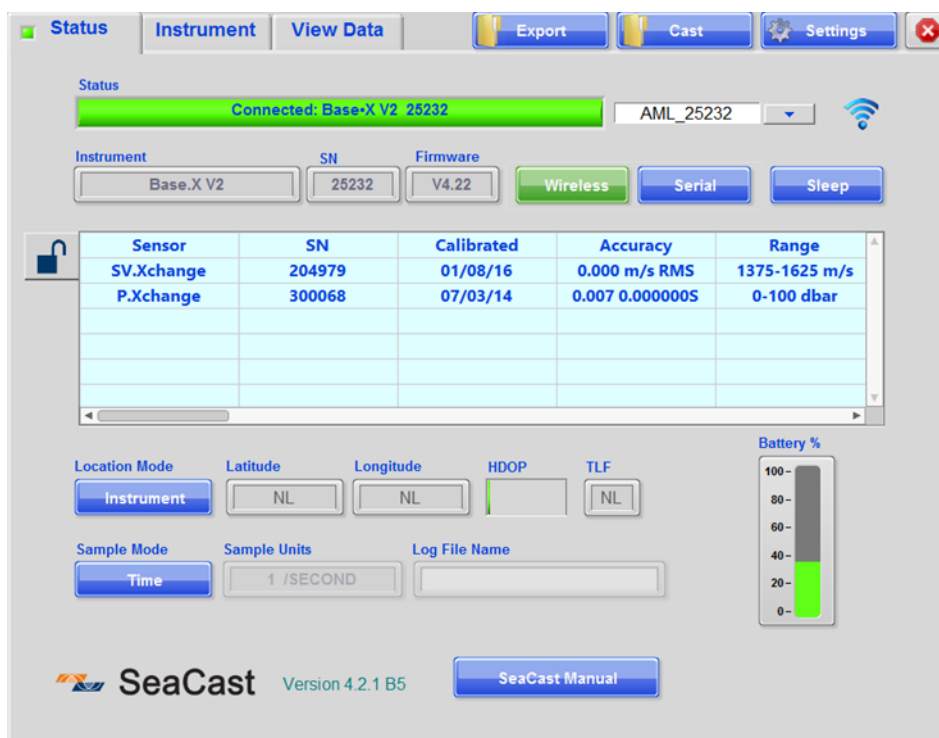

Launch SeaCast and verify that the instrument tab is displaying accurate SV•Xchange sensor information.

- Immerse the sensor (installed on the instrument) in fresh water. Ensure there are no bubbles on the sensor reflector or transducer face. Take a scan; the sound velocity output should agree with the graph below.

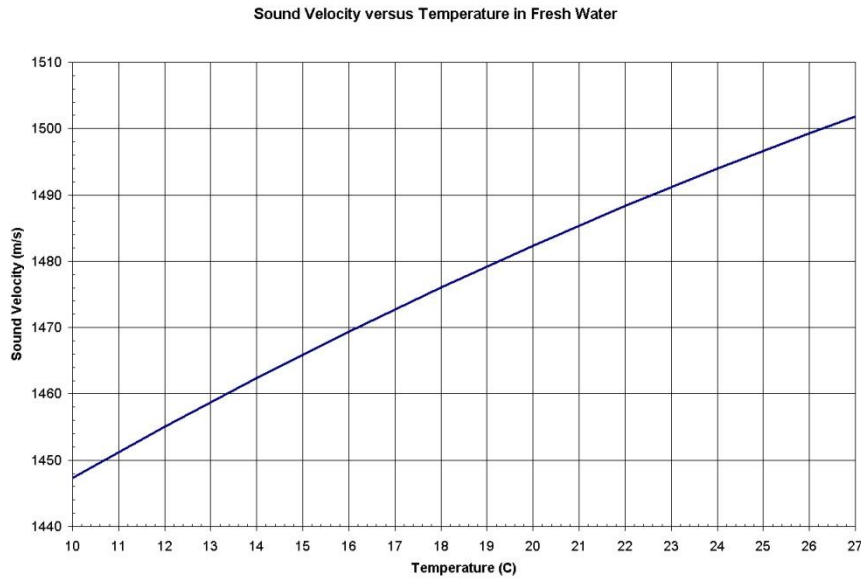

Returning a Sensor to the Factory

- If shipping for repair or recalibration, obtain an RMA number from the service centre.
- Pack the instrument in its original shipping box to prevent damage during shipping.

An RMA number can be requested using the contact options given in the Support section of this manual.

Using the Sensor

Pressure Ratings

SV•Xchange is rated to operate to a maximum depth of 6000m. However, the instrument the SV•Xchange sensor is used on will likely be depth limited by both its pressure case and pressure sensor. **Deployments should never exceed the lower of these two pressure ratings.**

Installing the Sensor

- Ensure that the instrument socket is clean and dry.
- Check the sensor's O-ring for cleanliness (see Inspecting and Replacing the O-Ring later in this manual).
- Align the sensor to the sensor mount.
- Place the sensor into the mount.
- Rotate the sensor until it drops down into the mount enough to allow the blue locking sleeve threads to engage the mount threads.
- Screw down the blue locking sleeve until it stops. The bottom of the sleeve should be within 1 mm of the instrument end cap.



Removing the Sensor

- If the sensor has been used in salt water, rinse it in fresh water.
- Dry the sensor before removal to protect the connector.
- Unscrew the blue locking sleeve.
- Lift the sensor out of the mount.
- Ensure that the instrument socket is dry and clean, using compressed air if necessary.
- Immediately insert the blanking plug or a replacement sensor in the open socket.



C•Xchange & SV•Xchange Blanking plug

Pre-Deployment Procedures

- Upon Receipt
 - Use the Shipping and Receiving instructions to verify the condition of the instrument.
 - Verify the sensor calibration is valid for the duration of the deployment. If not, swap the sensor for one with valid calibrations or send it to a service centre for recalibration.
- Before leaving the jetty
 - Ensure the sensor is properly mounted on the instrument. The blue locking sleeve should be fully threaded onto the sensor mount of the instrument, sitting less than 1mm from the instrument end cap.
 - Test the instrument in fresh water to ensure the sensor is functioning properly.

Post-Deployment Procedures

- Ensure the sensor is clean and dry before storage.

Maintaining the Sensor

Periodic Maintenance

Periodic maintenance will prolong the life of the sensor. The following steps are recommended:

- If the sensor is dirty or oily, allow it to soak in warm, soapy water before cleaning with a rag or soft brush. When finished, rinse with fresh water to remove any residual soap or dirt.
- Before each use:
 - Before installing on an instrument, check the O-ring under the blue locking sleeve of the sensor for silicon grease.
 - If O-ring is damaged, replace it with another. Type 2-116-N70D. See “Inspecting and Replacing the O-ring” later in this manual for more information.
 - If O-ring is dry or has been replaced due to damage, apply a small amount of silicone grease.
 - Ensure that the sensor is clean and undamaged.
 - Ensure that the sensor is properly installed on the instrument
- After each deployment:
 - Clean and rinse the sensor using fresh water.
 - Dry the sensor completely, and store it in a cool, dry place.
- Yearly
 - Send the sensor to a service centre for diagnostics and re-calibration.
 - Install connector and sensor blanking plugs in the instrument if not replacing sensors sent for calibration with others.
- Long term storage preparation
 - Ensure the instrument has been thoroughly cleaned and dried.
 - Remove all Xchange™ sensors from the instrument and dry the connectors.
 - Lubricate the underwater connectors (not Xchange™ mounts) with silicone spray.
 - Lubricate the retainer rings and O-rings with silicone grease.
 - Install connector and sensor blanking plugs in the instrument

Inspecting and Replacing the O-ring

It is crucial to keep the SV•Xchange sensor's O-ring clean and greased. Any fibres or dirt on the O-ring will allow water into the connector and damage both the sensor and the sensor mount. To gain access to the O-ring, perform the following steps:

- Remove the sensor from the instrument.
- Use a small screw driver to remove the retaining ring from the top of the blue locking sleeve.
- Slide the retaining ring over the transducer plate.
- Pinch the blue locking sleeve and slide it over the transducer plate.
- The O-ring should be slick with grease. If it is dry, apply silicone grease.
- Inspect the O-ring for dirt. Clean and reapply grease, if necessary.
- Inspect the O-ring for nicks and cracks. If any are found, the O-ring must be replaced. Use 2-116-N70D Buna Nitrile O-rings. Apply silicone grease to the new O-ring before using it.

Caution: Do not use a sharp instrument to remove the O-ring. If the O-ring groove is scratched, the O-ring will not provide a waterproof seal.

- Slide the blue locking sleeve back over the o-ring
- Re-install the retaining ring



Remove Retainer



Pinch Hard and Lift Sleeve



Check O-ring

Communications

SV•Xchange Commands

When using SeaCast, the full instrument command set is not usually necessary. However, text commands can be issued to the instrument and also to specific sensors on an instrument from SeaCast or any terminal emulation program, such as HyperTerminal.

There is additional command set functionality on SV•Xchange-equipped instruments. To use these commands, direct communication with the SV•Xchange sensor must be established. There are two ways to accomplish direct communication with SV•Xchange.

1. On a Micro•X instrument with a primary sensor mount, SV•Xchange commands can be given directly to the instrument by typing the commands into the terminal emulation program.
2. On all other X•Series instruments, the *TALK* command is used to direct communications to SV•Xchange. Use the following procedure to accomplish this:

Enter Talk Mode

- Establish communications with the instrument.
- Send the *DETECT* command to the instrument. The instrument will return a list of sensors detected on each slot of the instrument. SV•Xchange is usually in the primary slot, but on instruments equipped with C•Xchange or CT•Xchange, SV•Xchange may be located in a different slot.
- Send the *TALK 1* command to the instrument. **Replace the “1” in the command with the appropriate slot number if required.** This command directs subsequent communications directly to the sensor board.

Exit Talk Mode

- Press the CTRL and C keys simultaneously.

Specific Commands of Interest

| Command | Description |
|---------------------|--|
| DIS OPTIONS | Displays the current settings for the SV•Xchange. |
| DIS SV CAL | Displays the calibration information for the SV•Xchange. |
| SET xxxxx FORMAT ab | Changes the numerical output format of the sensor. Where xxxxx=sensor type (SV, CONDUCTIVITY, TEMPERATURE, PRESSURE). a = number of digits ahead of the decimal place. b = number of digits after the decimal place I.e. SET SV FORMAT 42 changes the scan output format to 1475.25 SEE BELOW |
| SET SV FORMAT 43 | Sets the SV format to 4 digits ahead of the decimal place and 3 digits after the decimal place. |
| SET SV FORMAT 42 | Sets the SV format to 4 digits ahead of the decimal place and 2 digits after the decimal place |
| SET SV FORMAT 41 | Sets the SV format to 4 digits ahead of the decimal place and 1 digits after the decimal place. |
| SET SV FORMAT 40 | Sets the SV format to 4 digits with no decimal. |

*For the full set of commands, please refer to the Commands section of an Instrument manual.

Support

Troubleshooting

Instrument fails to detect the sensor:

- Is the sensor properly mounted on the instrument?
- Check the connector on both the sensor and the instrument for corrosion or damaged contacts.
- Cycle power to the instrument.

SV sensor reads 0 m/s:

- Is the sensor immersed in water?
- Are there bubbles on the reflector plate or transducer face?
- Is the acoustic path obstructed by dirt or biofouling?
- Is the sensor damaged?
- Is the water excessively turbid?
- Is there electrical noise on the power or communication lines? There should be no transient spikes greater than 20 mV.

SV data is noisy:

- Check the connector on both the sensor and the instrument for corrosion or damaged contacts.
- Are there bubbles on the reflector plate or transducer face?
- Are there small scale thermal or salinity eddies or stratification of the water being tested?
- Is the water excessively turbid?
- Is there a nearby source of electromagnetic interference? Examples are arcing brushes on electric motors, radio transmitters, and faulty cathode ray tube monitors.
- Check the power supply to the sensor for noise. The power supply should have less than 30mV of noise.

SeaCast fails to recognize the sensor:

- Download the latest version of SeaCast at <http://www.amloceanographic.com/seacast>

Contact AML Oceanographic

Service

To request an RMA or technical support

Email: service@AMLOceanographic.com

Phone: 1-250-656-0771

Phone : 1-800-663-8721 (NA)

Fax: 1-250-655-3655

Sales

For all general sales inquiries

Email: sales@AMLOceanographic.com

Phone: 1-250-656-0771

Phone : 1-800-663-8721 (NA)

Fax: 1-250-655-3655

Website

<http://www.AMLOceanographic.com>

Customer Portal

My AML Oceanographic is AML's online data centre. This secure area within our website is designed to offer one easy location for interested individuals and organizations - distributors, customers, prospects, and other members of our community - to manage their interactions with AML. *My AML Oceanographic* will allow you to:

- View and manage your assets (instruments and sensors)
- Consult instrument diagnostic summaries
- View and download calibration and conformity certificates
- View and manage your technical support cases
- Consult and download sales estimates, sales orders, and invoice copies
- View account balances and generate account statements
- Assess inventory availability at AML

To access the Customer Portal, please navigate to the *Support* button - located on the top right of the AML Oceanographic home page - select *Customer Centre* from the options on the drop down menu and follow the instructions provided.

Mailing and Shipping Address

AML Oceanographic
2071 Malaview Ave.
Sidney, BC, Canada
V8L 5X6

Technical Specifications

Sensors

| Range | Accuracy | Precision | Resolution | Response Time |
|---------------|------------|------------|------------|---------------|
| 1375-1625 m/s | ±0.025 m/s | ±0.006 m/s | 0.001 m/s | 47 µs |

Mechanical Materials

| Housing | | | | |
|----------|----------|--------------|-----------------|-----------------|
| Status | Type | Depth Rating | Diameter | Length |
| Standard | Titanium | 6000m | 31.75mm (1.25") | 87.1 mm (3.43") |

Sampling Capabilities

- Samples up to 25 times per second.

Ordering Codes

| | |
|-------------|----------------------------------|
| XCH-SV-STD | SV•Xchange™ (1375-1625m/s) Range |
| XCH-SV-1120 | SV•Xchange™ (1100-2000m/s) Range |
| XCH-SV-0520 | SV•Xchange™ (500-2000m/s) Range |

Warranty

AML warrants the instrument for a period of TWO YEARS from the date of delivery. AML will repair or replace, at its option and at no charge, components which prove to be defective. The warranty applies only to the original purchaser of the instruments and only to instruments and sensors manufactured by AML Oceanographic. The warranty of third party sensors will apply as per the specific vendor's warranty policy. The warranty does not apply if the instrument has been damaged, by accident or misuse, and is void if repairs or modifications are made by other than authorized personnel.

This warranty is the only warranty for new product given by AML. No warranties implied by law, including but not limited to the implied warranties of merchantability and fitness for a particular purpose shall apply. In no event will AML be liable for any direct, indirect, consequential or incidental damages resulting from any defects or failure of performance of any instrument supplied by AML.

DISCLAIMER

AML reserves the right to make any changes in design or specifications at any time without incurring any obligation to modify previously delivered instruments. Manuals are produced for information and reference purposes and are subject to change without notice.

Technical Overview Drawings

THE INFORMATION CONTAINED IN THIS DRAWING IS THE SOLE PROPERTY OF AML OCEANOGRAPHIC LTD.
 ANY REPRODUCTION IN PART OR WHOLE WITHOUT THE WRITTEN PERMISSION OF AML OCEANOGRAPHIC LTD IS PROHIBITED

REVISION TABLE

| REV | DESCRIPTION | BY | DATE |
|-----|------------------------------------|-----|-----------|
| B | ADDED CTX | ABT | 15AUG2015 |
| C | UPDATED TUX & ADDED SENSOR WEIGHTS | LB | 27NOV2015 |
| D | UPDATED UVX | MS | 11MAY2016 |

C Xchange Right Angle

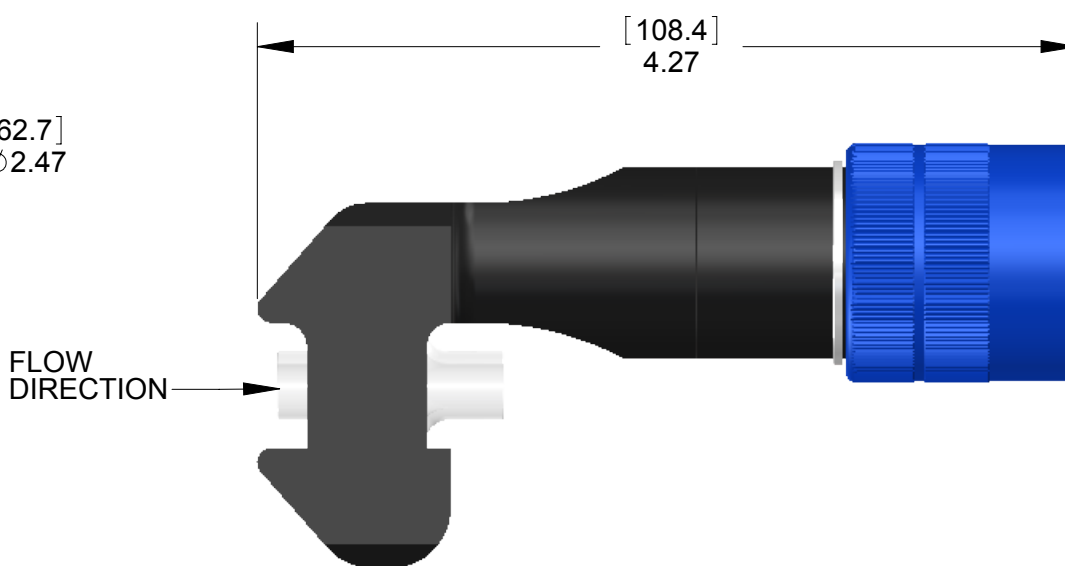
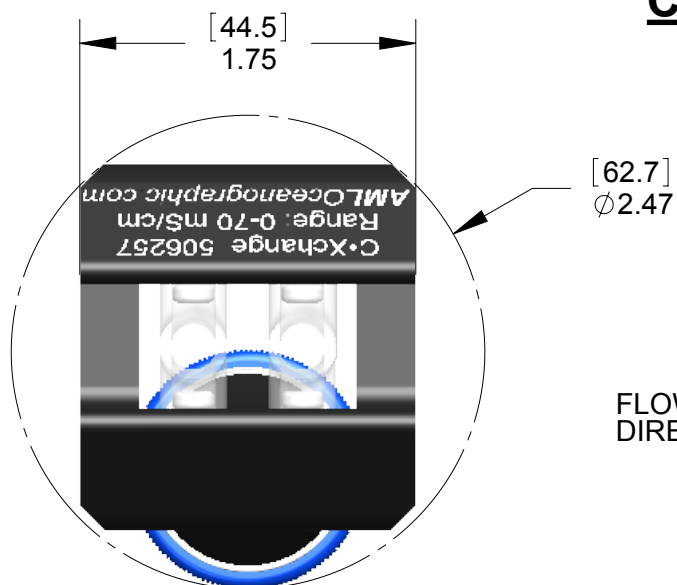

NOTE: WEIGHT = 120 g

C Xchange Straight

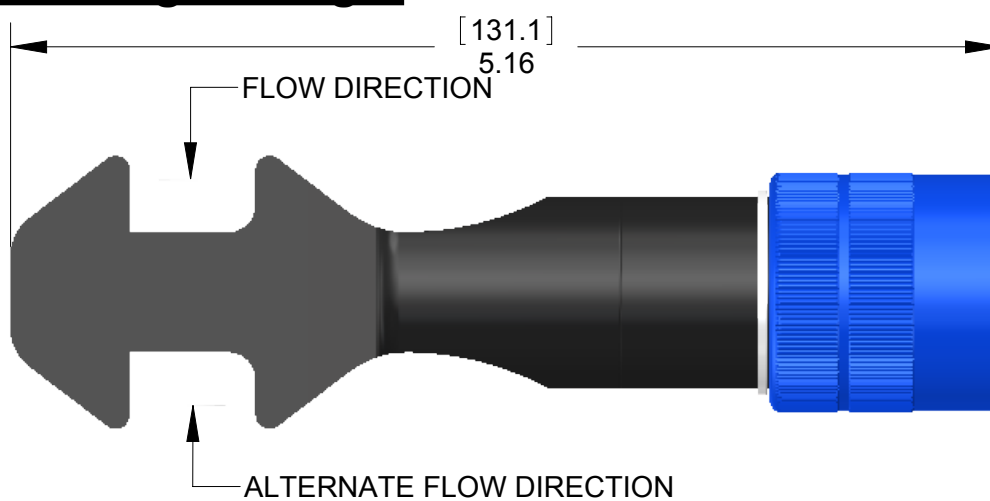
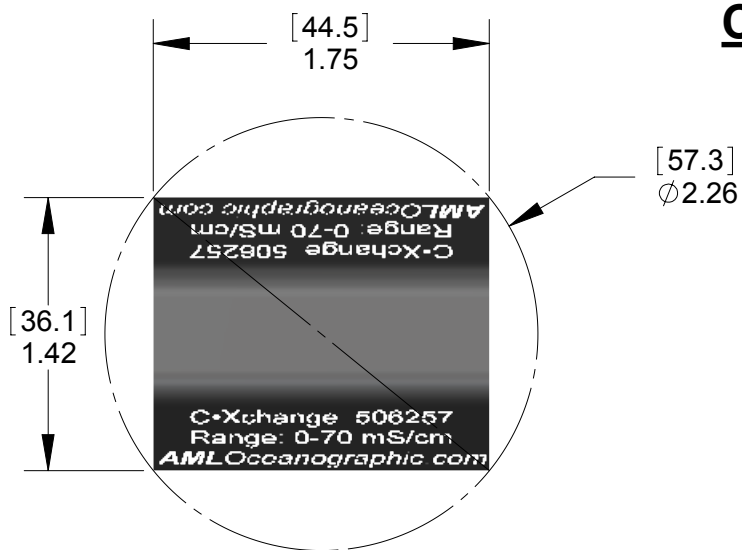

NOTE: WEIGHT = 132 g

CT Xchange

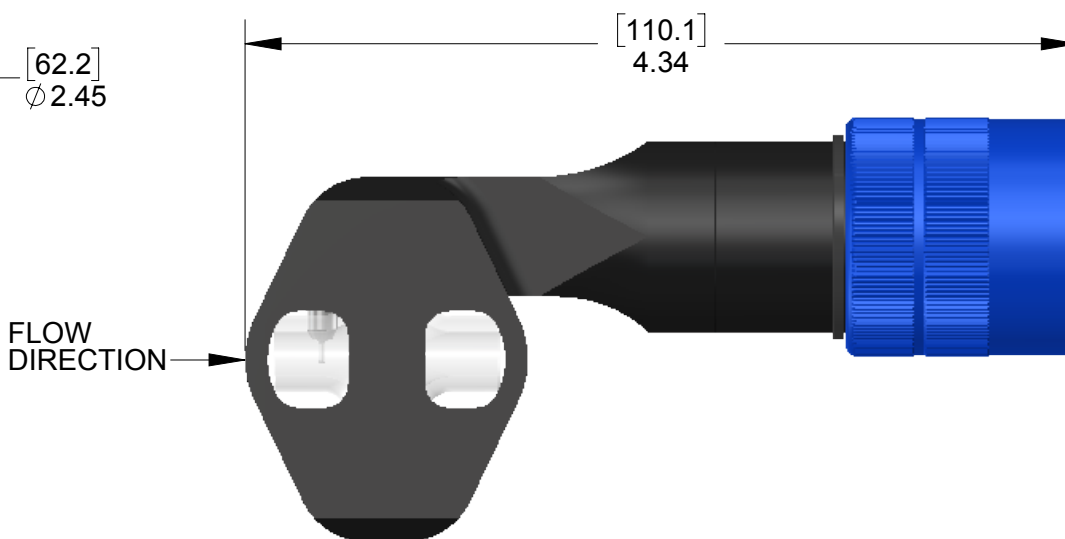
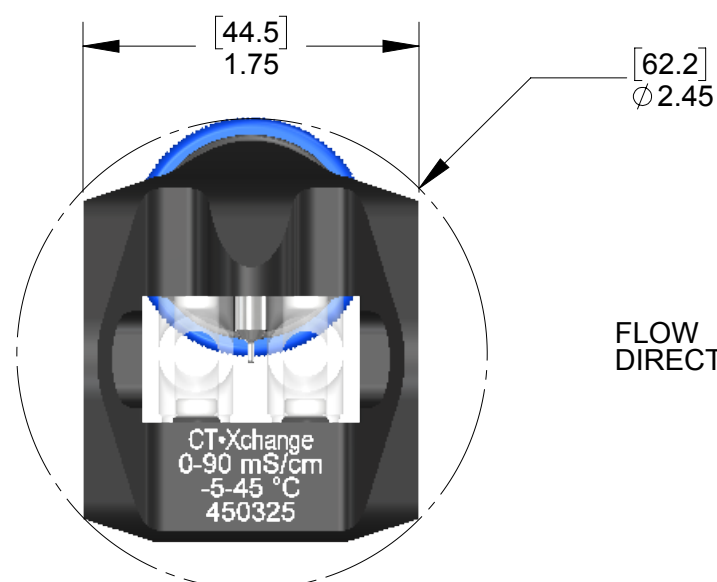

NOTE: WEIGHT = 110 g

NOTE: ALL WEIGHTS MEASURED IN AIR



2071 Malview Avenue W., Sidney B.C. Canada V8L 5X6 (250) 656 0771 Fax: (250) 655 3655

TOLERANCES:

ANGLES: ± 1°
 FRACTIONS: ± 1/32
 HOLE SIZES: ± 0.005(0.13)
 0.00: ± 0.015(0.38)
 0.000: ± 0.005(0.13)

UNLESS OTHERWISE SPECIFIED:

ORIGINAL SCALE: 1:1
 DIM'S ARE IN INCHES (MM)
 SURFACE FINISH: 63

TITLE:

Xchange Sensor / Device Overview

DRAWN

I.L.

DRAWING NO.:

SNS-GA-03351-D

REV

AML NO.

N/A

DATE

26FEB2010

MATERIAL:

N/A

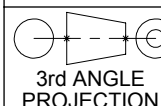

SIZE B

SLD FILE NO.:

N/A

SHEET NO.

Sheet 1 of 3

THE INFORMATION CONTAINED IN THIS DRAWING IS THE SOLE PROPERTY OF AML OCEANOGRAPHIC LTD.
 ANY REPRODUCTION IN PART OR WHOLE WITHOUT THE WRITTEN PERMISSION OF AML OCEANOGRAPHIC LTD IS PROHIBITED

REVISION TABLE

| REV | DESCRIPTION | BY | DATE |
|-----|------------------------------------|-----|-----------|
| B | ADDED CTX | ABT | 15AUG2015 |
| C | UPDATED TUX & ADDED SENSOR WEIGHTS | LB | 27NOV2015 |
| D | UPDATED UVX | MS | 11MAY2016 |

P Xchange

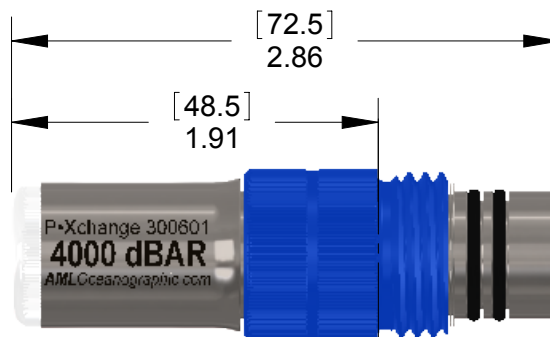
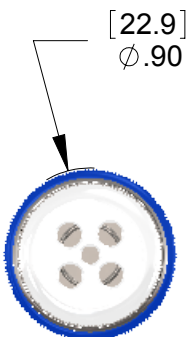

NOTE: WEIGHT = 57 g

ENDCAP FACE LEVEL WHEN INSTALLED ON INSTRUMENT OR BULKHEAD.

SV Xchange

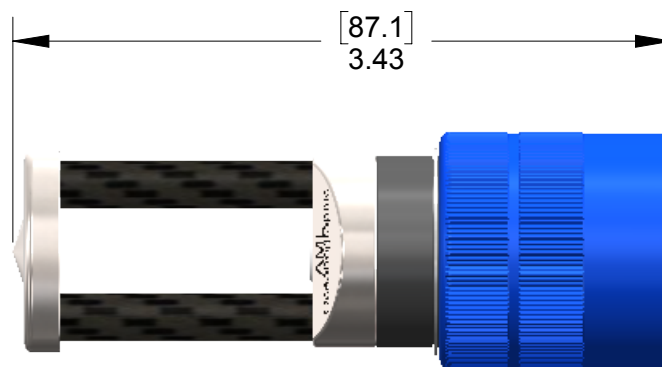
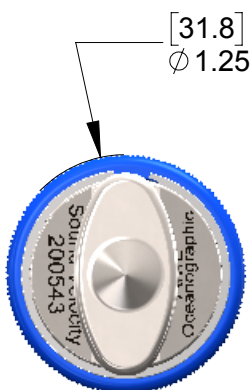

NOTE: WEIGHT = 62 g

T Xchange

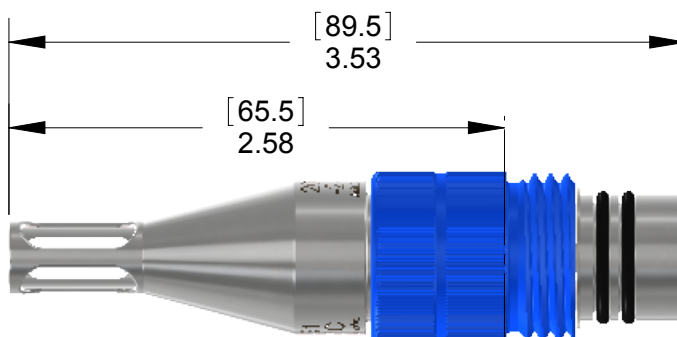
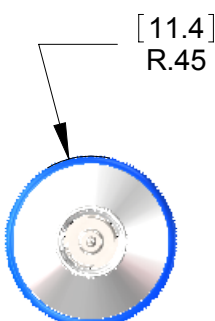

NOTE: WEIGHT = 60 g

ENDCAP FACE LEVEL WHEN INSTALLED ON INSTRUMENT OR BULKHEAD.

NOTE: ALL WEIGHTS MEASURED IN AIR



2071 Malaview Avenue W., Sidney B.C. Canada V8L 5X6 (250) 656 0771 Fax: (250) 655 3655

TOLERANCES:

ANGLES: ± 1°
 FRACTIONS: ± 1/32
 HOLE SIZES: ± 0.005(0.13)
 0.00: ± 0.015(0.38)
 0.000: ± 0.005(0.13)

UNLESS OTHERWISE SPECIFIED:

ORIGINAL SCALE: 1:1
 DIM'S ARE IN INCHES (MM)
 SURFACE FINISH: 63

TITLE:

Xchange Sensor / Device Overview

DRAWN

I.L.

DRAWING NO.:

SNS-GA-03351-D

REV

N/A

AML NO.

N/A

DATE

26FEB2010

MATERIAL:

N/A

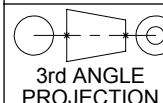

SIZE B

SLD FILE NO.:

N/A

SHEET NO.

Sheet 2 of 3

THE INFORMATION CONTAINED IN THIS DRAWING IS THE SOLE PROPERTY OF AML OCEANOGRAPHIC LTD.
 ANY REPRODUCTION IN PART OR WHOLE WITHOUT THE WRITTEN PERMISSION OF AML OCEANOGRAPHIC LTD IS PROHIBITED

REVISION TABLE

| REV | DESCRIPTION | BY | DATE |
|-----|------------------------------------|-----|-----------|
| B | ADDED CTX | ABT | 15AUG2015 |
| C | UPDATED TUX & ADDED SENSOR WEIGHTS | LB | 27NOV2015 |
| D | UPDATED UVX | MS | 11MAY2016 |

Tu Xchange

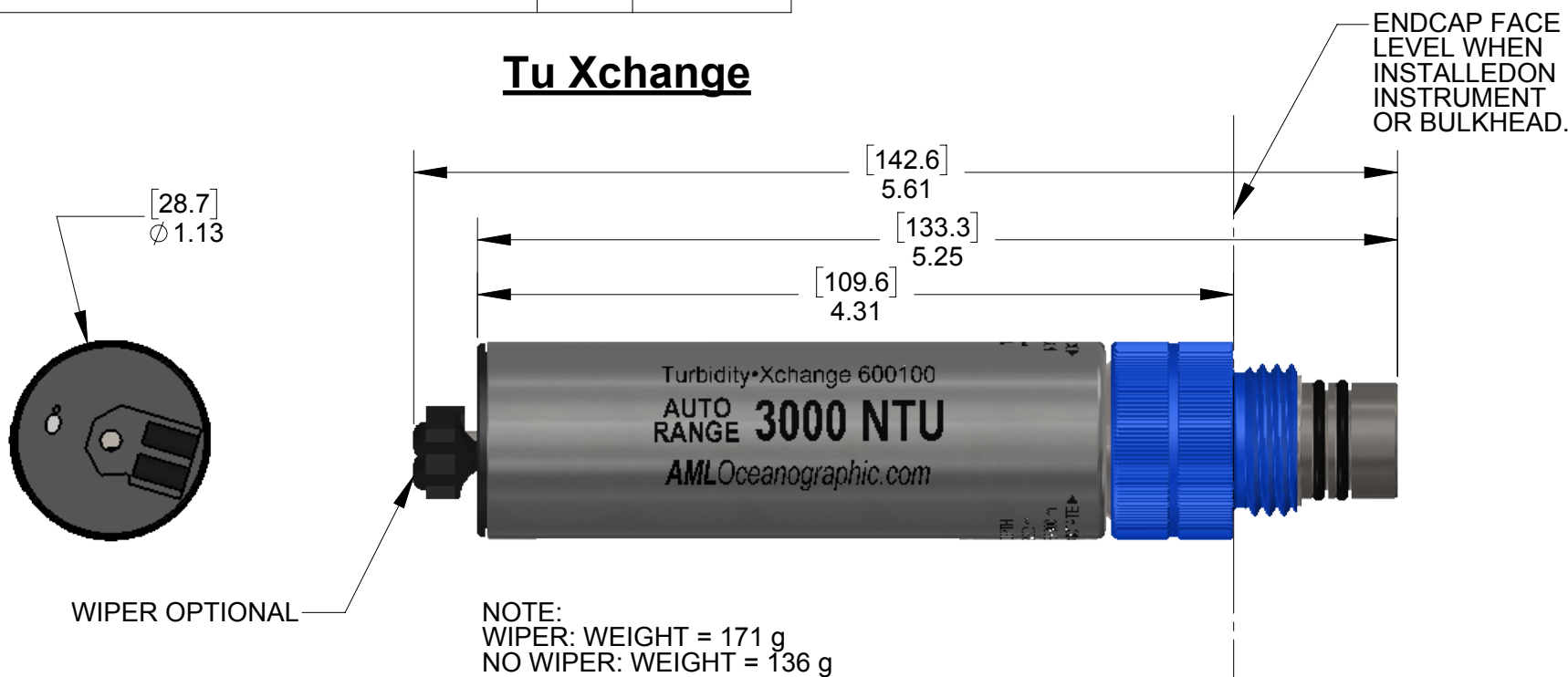

UV Xchange

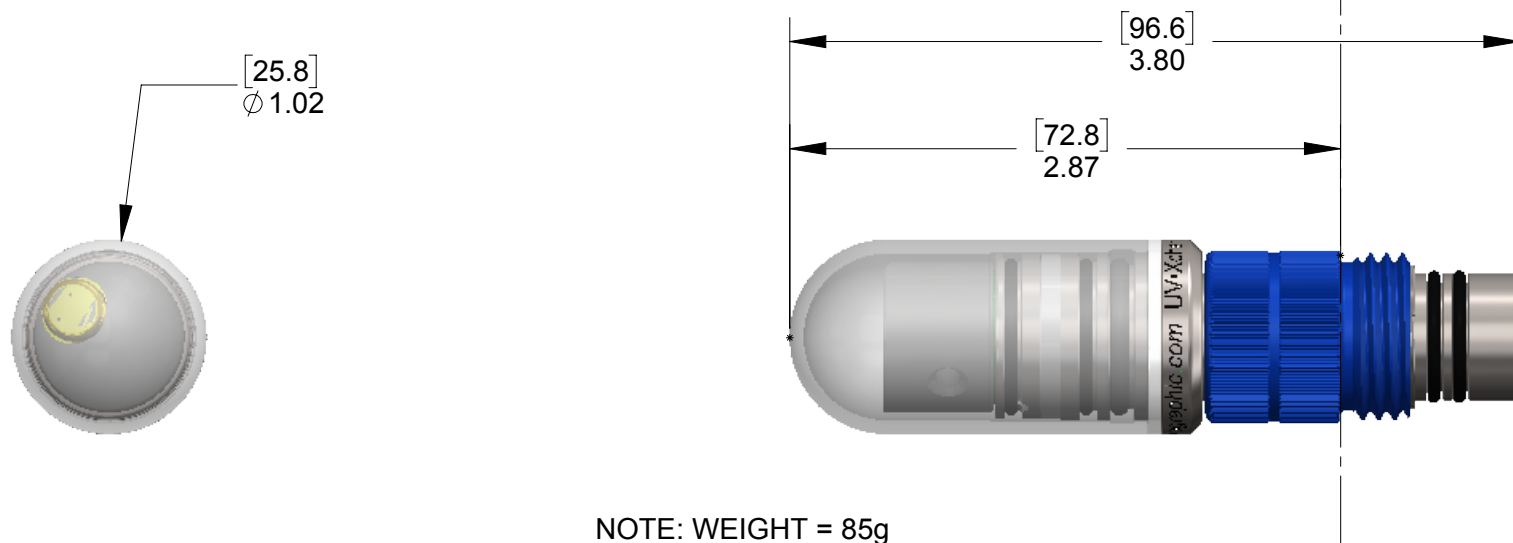
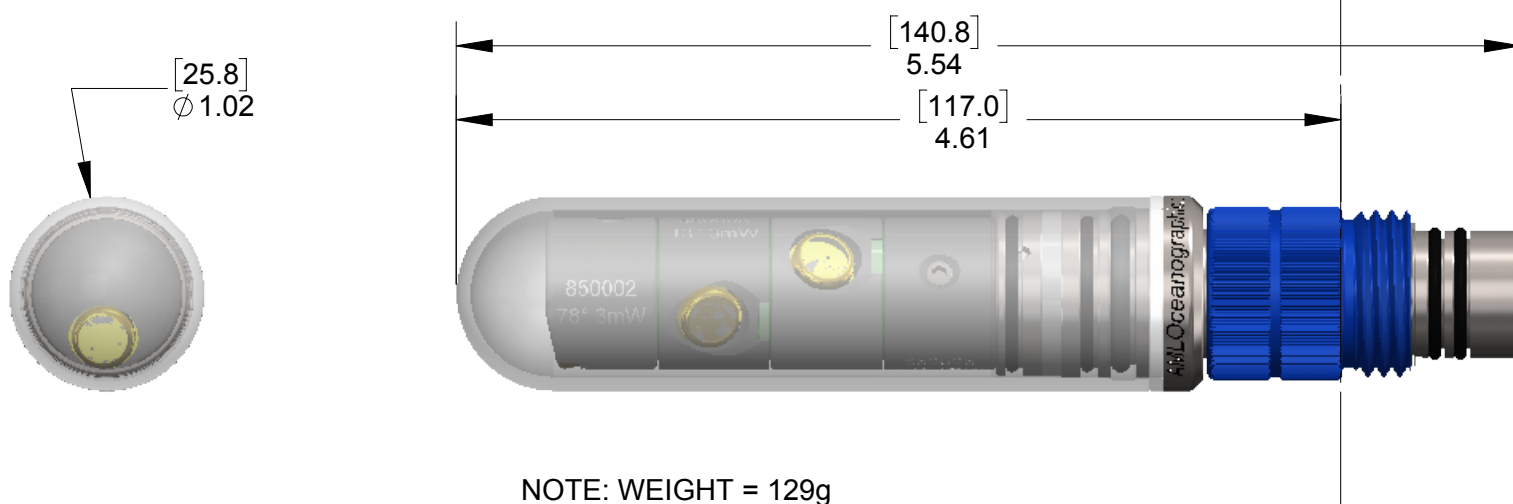

NOTE: ALL WEIGHTS MEASURED IN AIR



2071 Malaview Avenue W., Sidney B.C. Canada V8L 5X6 (250) 656 0771 Fax: (250) 655 3655

TOLERANCES:

ANGLES: ± 1°
 FRACTIONS: ± 1/32
 HOLE SIZES: ± 0.005(0.13)
 0.00: ± 0.015(0.38)
 0.000: ± 0.005(0.13)

UNLESS OTHERWISE SPECIFIED:

ORIGINAL SCALE: 1:1
 DIM'S ARE IN INCHES (MM)
 SURFACE FINISH: 63

| | | | |
|---|---------------------------------------|----------------------------------|-----------------------|
| TITLE: Turbidity Xchange Sensor | | | |
| DRAWN I.L. | DRAWING NO.: SNS-GA-03351-D | REV N/A | AML NO. N/A |
| DATE 26FEB2010 | MATERIAL: N/A | | |
| 3rd ANGLE PROJECTION SIZE B | SLD FILE NO.: N/A | SHEET NO. Sheet 3 of 3 | |