



T•Xchange™ User Manual



Version 1.24
20 May 2016

Revision History

Revision	Date	Description	Author
Version 1.0	06 Dec 2012	Added Revisions. Updated Website information.	Erika Ladouceur
Version 1.1	20 June 2013	Format revision and updates	Jehan Zouak
Version 1.2	25 March 2014	Added Technical Drawing	Jehan Zouak
Version 1.21	19 September 2014	Updated technical drawing	Jehan Zouak
Version 1.22	30 July 2015	Command section edit.	Jehan Zouak
Version 1.23	12 April 2016	Specification updates	Jehan Zouak
Version 1.24	20 May 2016	Minor updates	Jehan Zouak

Table of Contents

General Description of the Sensor	2
Where Do I Start?	3
Shipping and Receiving	4
Receiving the Sensor	4
Returning a Sensor to the Factory	4
Using the Sensor	5
Pressure Ratings	5
Installing the Sensor	5
Removing the Sensor	5
Pre-Deployment Procedures	6
Post-Deployment Procedures	6
Maintaining the Sensor	7
Periodic Maintenance	7
Inspecting and Replacing the O-rings	8
Communications	9
T•Xchange Commands	9
Support	10
Troubleshooting	10
Contact AML Oceanographic	11
Technical Specifications	12
Ordering Codes	12
Warranty	13
Technical Overview Drawings	14

General Description of the Sensor

AML Oceanographic's T•Xchange™ sensor is the industry's only field-swappable temperature sensor.

T•Xchange sensors store all pertinent manufacturing and calibration data internally. This allows the sensor to be swapped between any T•Xchange enabled instruments without manually updating the calibration coefficients. Calibration sheets can be printed on demand by any instrument connected to the SeaCast software. Re-calibrations only require the sensor, not the instrument, to be shipped to the service centre.

T•Xchange sensors are engraved at the factory with a unique serial number and the temperature range of the sensor as shown in the image below.

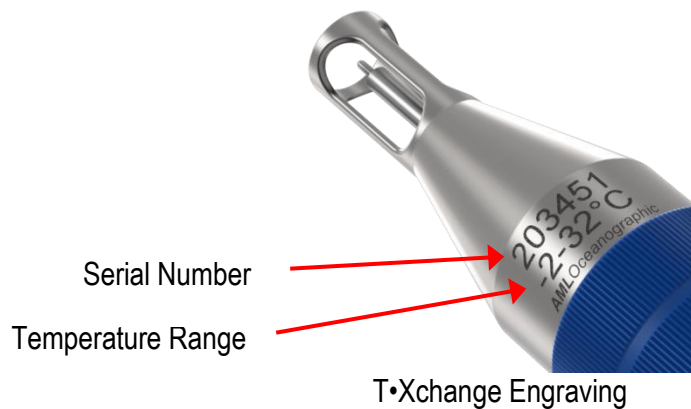

Where Do I Start?

AML Oceanographic X•Series instruments ship with several manuals on the USB:

- An instrument manual providing an overview on how to use and maintain the instrument;
- A SeaCast manual providing instructions on how to use the software to configure the instrument and review instrument data;
- Xchange™ sensor manuals (CT•Xchange, C•Xchange, SV•Xchange, P•Xchange, T•Xchange, and Tu•Xchange) providing overviews on how to install and maintain each of the Xchange™ sensors;

If you are configuring an instrument for field use or lab testing, begin with the SeaCast manual.

If you are performing instrument maintenance, begin with the instrument manual.

If you are planning to swap an Xchange™ sensor, read the Xchange™ manual corresponding to your sensors.

Shipping and Receiving

Receiving the Sensor

When receiving a new sensor, perform the following steps to ensure the sensor will be ready for deployment when required:

- Inspect the shipping container, looking for signs of damage. Damage to the shipping container could indicate damage to the sensor inside.
- Inspect for damage
 - Check the sensor for cracks or bends
 - Check the connector for corrosion, dirt, and salt deposits
- Connect the sensor to an instrument, ensuring it is installed tightly onto its mount. The blue locking sleeve should be tight, and sitting less than 1mm from the instrument end cap.
- Connect the instrument to a computer using the data cable. Launch SeaCast and verify that the instrument tab is displaying accurate T•Xchange sensor information. The sensor's serial number and last calibration date should be displayed.
- On the *View Data* page select "Monitor," and allow the instrument to sample some data, as shown below. You would expect to see readings in degrees C of the current temperature. This will confirm the sensor is working.

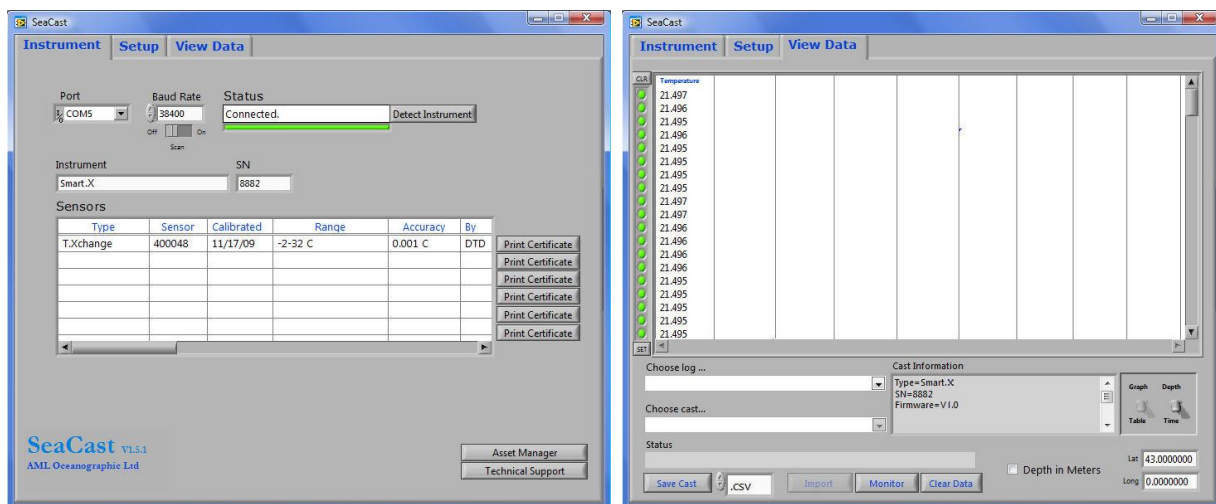

Returning a Sensor to the Factory

- If shipping for repair or recalibration, obtain an RMA number from the service centre.
- Pack the instrument in its original shipping box to prevent damage during shipping.

An RMA number can be requested using the contact options given in the Support section of this manual.

Using the Sensor

Pressure Ratings

The T•Xchange sensor is rated to operate to a maximum depth of 6000m. However, the instrument the T•Xchange sensor is used on will likely be depth limited by both its pressure case and pressure sensor. **Any deployment should never exceed the lower of these two pressure ratings.**

Installing the Sensor

- Select a T•Xchange temperature range that is compatible with your deployment.
- Ensure that the instrument socket is clean and dry.
- Check the sensor's O-ring for cleanliness (see below, Inspecting & Replacing the O-Rings).
- Align the sensor to the sensor mount.
- Place the sensor into the mount.
- Rotate the sensor until it drops down into the mount enough to allow the blue locking sleeve threads to engage the mount threads.
- Screw down the blue locking sleeve until it stops. The bottom of the sleeve should be within 1 mm of the instrument end cap.

Removing the Sensor

- If the sensor has been used in salt water, rinse the sensor in fresh water.
- Dry the sensor before removal to protect the connector.
- Unscrew the blue locking sleeve.
- Lift the sensor out of the mount.
- Ensure that the instrument socket is dry and clean, using compressed air if necessary.
- Immediately insert the blanking plug or a replacement sensor in the open socket.



T•Xchange, P•Xchange & Tu•Xchange blanking plug

Pre-Deployment Procedures

- Upon Receipt
 - Use the Receiving the Sensor instructions to verify the condition of the instrument.
 - Ensure that the installed T•Xchange sensor has the correct temperature range for the deployment. If necessary, swap with another calibrated T•Xchange sensor with the correct range
 - Verify the sensor calibration is valid for the duration of the deployment. If not, swap the sensor for one with valid calibrations or send it to a service centre for recalibration.
- Before leaving the jetty
 - Ensure the sensor is properly mounted on the instrument. The blue locking sleeve should be fully threaded onto the sensor mount of the instrument, sitting less than 1mm from the instrument end cap.
 - Test the instrument in water to ensure the sensor is functioning properly.

Post-Deployment Procedures

- Ensure the sensor is clean and dry before storage.

Maintaining the Sensor

Periodic Maintenance

Periodic maintenance will prolong the life of the sensor. The following steps are recommended:

- If the sensor is dirty or oily, allow it to soak in warm, soapy water before cleaning with a rag or soft brush. When finished, rinse with fresh water to remove any residual soap or dirt.
- Before each use:
 - Before installing on an instrument, check the O-rings under the blue locking sleeve of the sensor for silicon grease.
 - Ensure that the sensor is clean and undamaged.
 - Ensure that the sensor is properly installed on the instrument
- After each deployment:
 - Clean and rinse the sensor using fresh water.
 - Dry the sensor completely, and store it in a cool, dry place.
- Yearly
 - Send the sensor to a service centre for diagnostics and re-calibration.
- Long term storage preparation
 - Ensure the instrument has been thoroughly cleaned and dried.
 - Remove all Xchange™ sensors from the instrument and dry the connectors.
 - Lubricate the instrument and Xchange™ sensor connector contacts with a silicone spray.
 - Lubricate the retainer rings and O-rings with silicone grease.
 - Install connector and sensor blanking plugs in the instrument.

Inspecting and Replacing the O-rings

It is crucial to keep the T•Xchange sensor's O-rings clean and greased. Any fibres or dirt on the O-rings will allow water into the connector and damage both the sensor and the sensor mount. To gain access to the O-rings, perform the following steps:

- Remove the sensor from the instrument
- The O-rings should be slick with grease. If they are dry, apply silicone grease.
- Inspect the O-rings for dirt. Clean and reapply grease, if necessary
- Inspect the O-rings for nicks and cracks. If any are found, the O-rings must be replaced. Use 2-015-N70D Buna Nitrile O-rings. Apply silicone grease to the new O-rings before using them.

Caution: Do not use a sharp instrument to remove the O-rings. If the O-ring grooves are scratched, the O-rings will not provide a waterproof seal. The O-rings can be removed easily with bare hands as shown below.

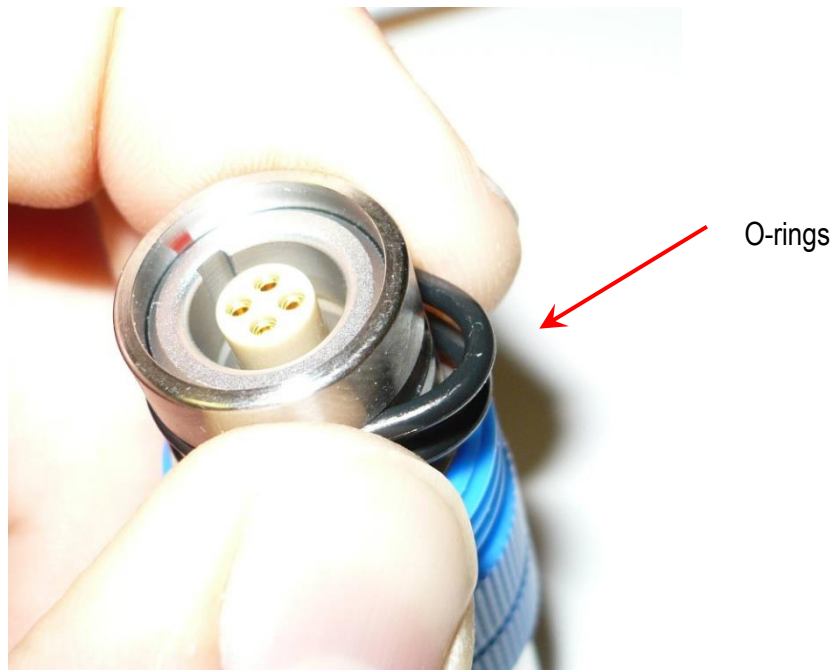

O-ring Removal

Communications

T•Xchange Commands

When using SeaCast, the full instrument command set is not usually necessary. However, the operator can issue text commands to the instrument as well as to specific sensors on an instrument. This can be done from SeaCast or any terminal emulation program such as HyperTerminal.

There is additional functionality on T•Xchange equipped instruments with respect to the command set. To use these commands, direct communication with the T•Xchange sensor must be established. There are two ways to accomplish direct communication with the T•Xchange sensor.

1. On a Micro•X instrument with the T•Xchange option, the T•Xchange commands can be given directly to the instrument by typing the commands into the terminal emulation program.
2. On all other X•Series instruments, the *TALK* command is used to direct communications to the T•Xchange sensor. Use the following procedure to achieve this:

Entering Talk Mode

- Establish communications with the instrument.
- Send the *DETECT* command to the instrument. The instrument will return a list of sensors detected on each slot of the instrument. Note the slot number for the T•Xchange sensor.
- Send the *TALK 2* command to the instrument. **Replace the “2” in the command with the appropriate slot number if required.** This command directs subsequent communications directly to the sensor board.

Exiting Talk Mode

- Press the CTRL and C keys simultaneously.

Specific Commands of Interest

Command	Description
DIS OPTIONS	Displays the current settings for the T•Xchange.
DIS TEMP CAL	Displays the calibration information for the T•Xchange.
SET xxxxx FORMAT ab	Changes the numerical output format of the sensor. Where xxxxx=sensor type (SV, CONDUCTIVITY, TEMPERATURE, PRESSURE). a = number of digits ahead of the decimal place. b = number of digits after the decimal place I.e. SET SV FORMAT 42 changes the scan output format to 1475.25 SEE BELOW
SET TEMP FORMAT 23	Sets the T format to 2 digits ahead of the decimal place and 3 digits after the decimal place.
SET TEMP FORMAT 22	Sets the T format to 2 digits ahead of the decimal place and 2 digits after the decimal place.
SET TEMP FORMAT 21	Sets the T format to 2 digits ahead of the decimal place and 1 digit after the decimal place.

*For the full set of commands, please refer to the Commands section of an Instrument manual.

Support

Troubleshooting

Instrument fails to detect the sensor:

- Is the sensor properly mounted on the instrument?
- Check the connector on both the sensor and the instrument for corrosion or damaged contacts.
- Cycle the instrument power.

Temperature data is noisy:

- Check the connector on both the sensor and the instrument for corrosion or damaged contacts
- Is the instrument subject to vibrations?
- Are there temperature eddies in the water being tested?
- Is there a nearby source of electromagnetic interference? Examples are arcing brushes on electric motors, radio transmitters, switching power supplies, and faulty cathode ray tube monitors.
- Check the power supply to the sensor for noise. Ideally the power supply should have less than 30mV of noise.

SeaCast fails to recognize the sensor:

- Be sure to download the latest version of SeaCast.

Contact AML Oceanographic

Service

To request an RMA or technical support

Email: service@AMLOceanographic.com

Phone: 1-250-656-0771

Phone : 1-800-663-8721 (NA)

Fax: 1-250-655-3655

Sales

For all general sales inquiries

Email: sales@AMLOceanographic.com

Phone: 1-250-656-0771

Phone : 1-800-663-8721 (NA)

Fax: 1-250-655-3655

Website

<http://www.AMLOceanographic.com>

Customer Portal

My AML Oceanographic is AML's online data centre. This secure area within our website is designed to offer one easy location for interested individuals and organizations - distributors, customers, prospects, and other members of our community - to manage their interactions with AML. *My AML Oceanographic* will allow you to:

- View and manage your assets (instruments and sensors)
- Consult instrument diagnostic summaries
- View and download calibration and conformity certificates
- View and manage your technical support cases
- Consult and download sales estimates, sales orders, and invoice copies
- View account balances and generate account statements
- Assess inventory availability at AML

To access the Customer Portal, please navigate to the *Support* button - located on the top right of the AML Oceanographic home page - select *Customer Centre* from the options on the drop down menu and follow the instructions provided.

Mailing and Shipping Address

AML Oceanographic
2071 Malaview Ave.
Sidney, BC, Canada
V8L 5X6

Technical Specifications

Sensors

Range	Accuracy	Precision	Resolution	Response Time
-2 to 32 °C	±0.005 °C	±0.003 °C	0.001 °C	100 ms
-5 to 45 °C ¹	±0.005 °C	±0.003 °C	0.001 °C	100 ms

¹ Will over-range to 60 °C. Inquire for specifications.

Mechanical Materials

Housing				
Status	Type	Depth Rating	Diameter	Length
Standard	Titanium	6000 m	22.9mm (0.9")	89.6 mm (3.53")

Sampling Capabilities

- Samples up to 25 times per second

Ordering Codes

XCH-TMP-N232	T•Xchange™ (-2 to 32 C) Range
XCH-TMP-N545	T•Xchange™ (-5 to 45 C) Range

Warranty

AML warrants the instrument for a period of TWO YEARS from the date of delivery. AML will repair or replace, at its option and at no charge, components which prove to be defective. The warranty applies only to the original purchaser of the instruments and only to instruments and sensors manufactured by AML Oceanographic. The warranty of third party sensors will apply as per the specific vendor's warranty policy. The warranty does not apply if the instrument has been damaged, by accident or misuse, and is void if repairs or modifications are made by other than authorized personnel.

This warranty is the only warranty for new product given by AML. No warranties implied by law, including but not limited to the implied warranties of merchantability and fitness for a particular purpose shall apply. In no event will AML be liable for any direct, indirect, consequential or incidental damages resulting from any defects or failure of performance of any instrument supplied by AML.

DISCLAIMER

AML reserves the right to make any changes in design or specifications at any time without incurring any obligation to modify previously delivered instruments. Manuals are produced for information and reference purposes and are subject to change without notice.

Technical Overview Drawings

THE INFORMATION CONTAINED IN THIS DRAWING IS THE SOLE PROPERTY OF AML OCEANOGRAPHIC LTD.
 ANY REPRODUCTION IN PART OR WHOLE WITHOUT THE WRITTEN PERMISSION OF AML OCEANOGRAPHIC LTD IS PROHIBITED

REVISION TABLE

REV	DESCRIPTION	BY	DATE
B	ADDED CTX	ABT	15AUG2015
C	UPDATED TUX & ADDED SENSOR WEIGHTS	LB	27NOV2015
D	UPDATED UVX	MS	11MAY2016

C Xchange Right Angle

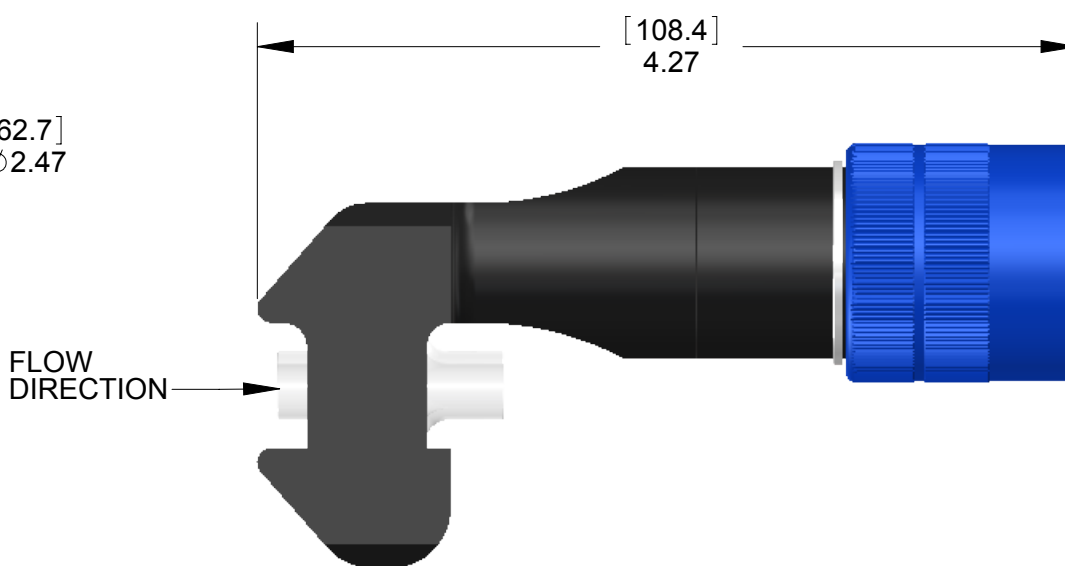
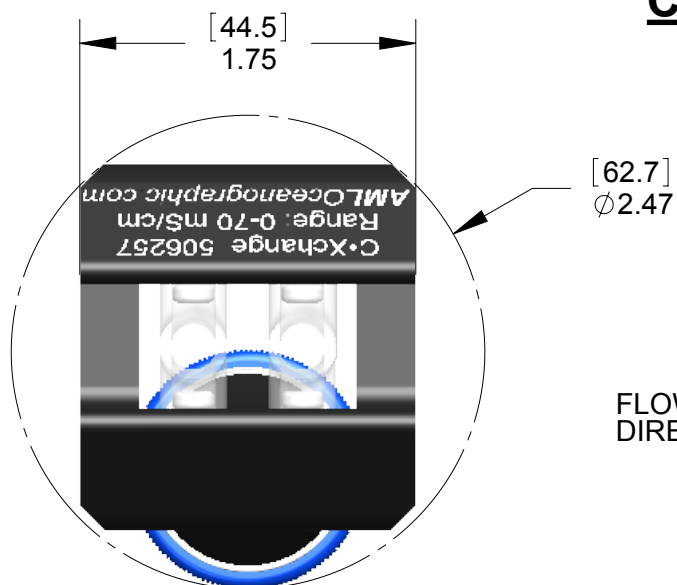

NOTE: WEIGHT = 120 g

C Xchange Straight

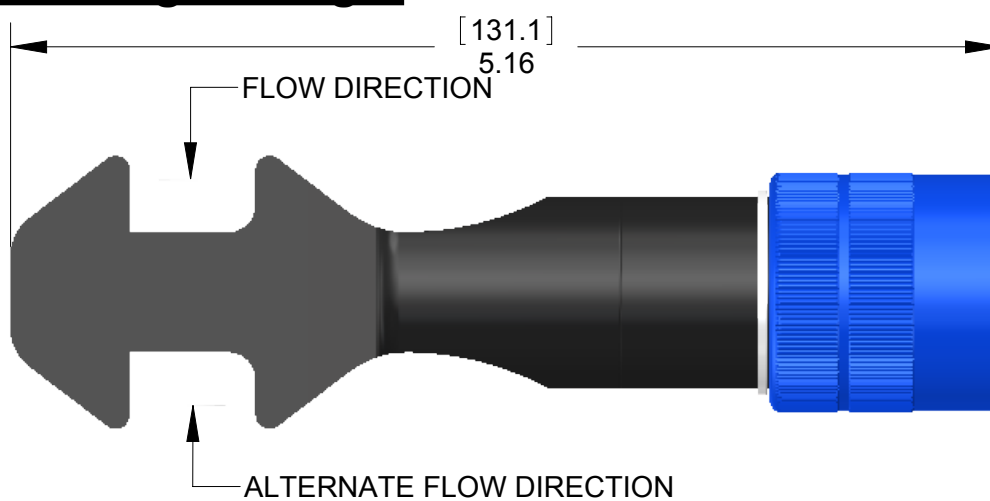
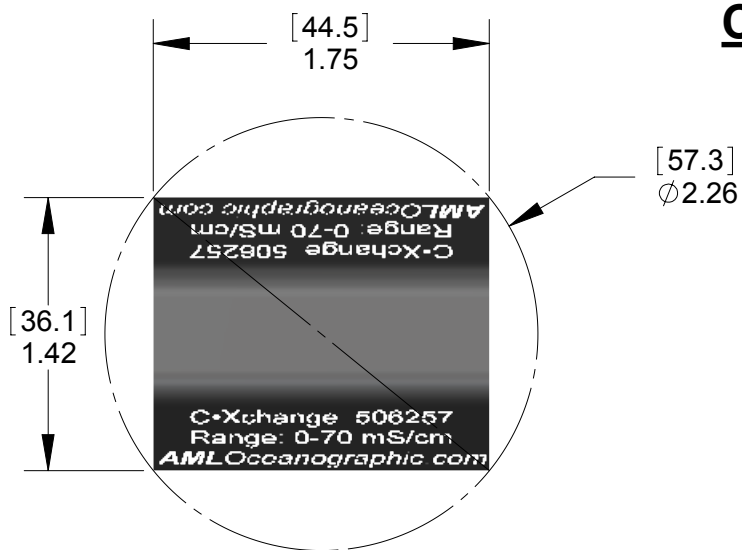

NOTE: WEIGHT = 132 g

CT Xchange

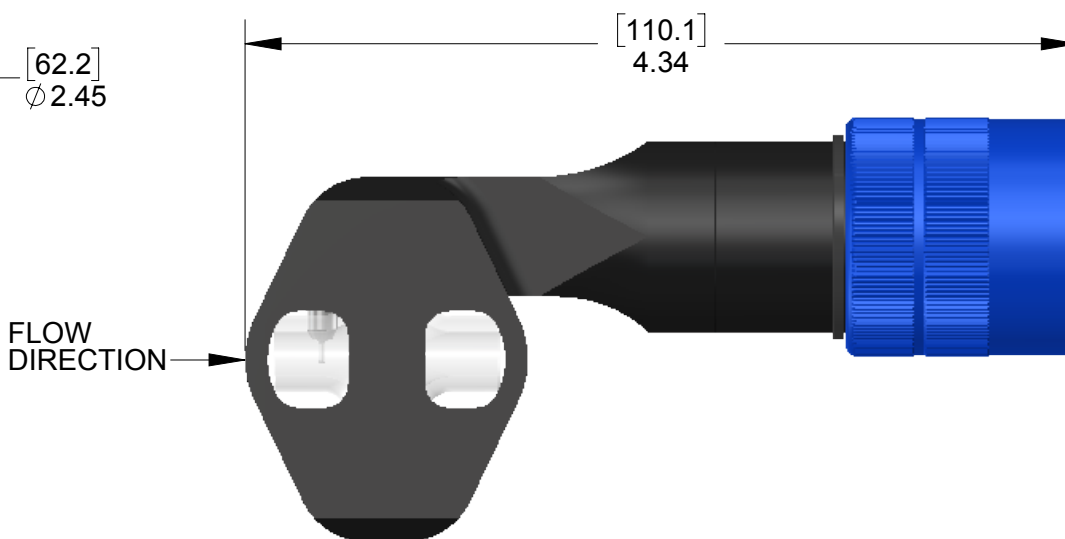
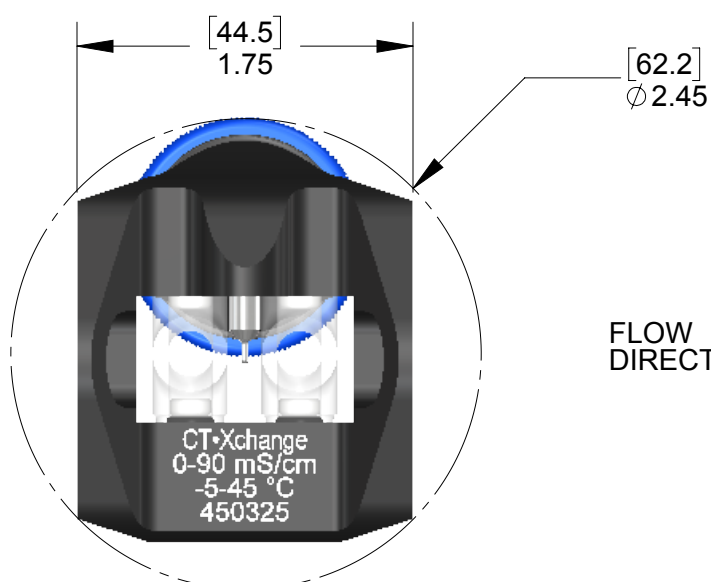

NOTE: WEIGHT = 110 g

NOTE: ALL WEIGHTS MEASURED IN AIR



2071 Malview Avenue W., Sidney B.C. Canada V8L 5X6 (250) 656 0771 Fax: (250) 655 3655

TOLERANCES:

ANGLES: ± 1°
 FRACTIONS: ± 1/32
 HOLE SIZES: ± 0.005(0.13)
 0.00: ± 0.015(0.38)
 0.000: ± 0.005(0.13)

UNLESS OTHERWISE SPECIFIED:

ORIGINAL SCALE: 1:1
 DIM'S ARE IN INCHES (MM)
 SURFACE FINISH: 63

TITLE:

Xchange Sensor / Device Overview

DRAWN	I.L.	DRAWING NO.:	SNS-GA-03351-D	REV		AML NO.	N/A
DATE	26FEB2010	MATERIAL:	N/A				
3rd ANGLE PROJECTION		SLD FILE NO.:	N/A		SHEET NO.		
SIZE B				Sheet 1 of 3			

THE INFORMATION CONTAINED IN THIS DRAWING IS THE SOLE PROPERTY OF AML OCEANOGRAPHIC LTD.
 ANY REPRODUCTION IN PART OR WHOLE WITHOUT THE WRITTEN PERMISSION OF AML OCEANOGRAPHIC LTD IS PROHIBITED

REVISION TABLE

REV	DESCRIPTION	BY	DATE
B	ADDED CTX	ABT	15AUG2015
C	UPDATED TUX & ADDED SENSOR WEIGHTS	LB	27NOV2015
D	UPDATED UVX	MS	11MAY2016

P Xchange

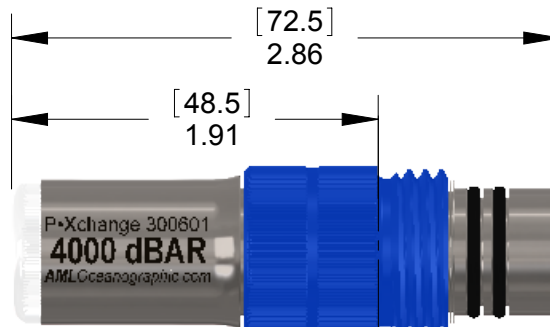
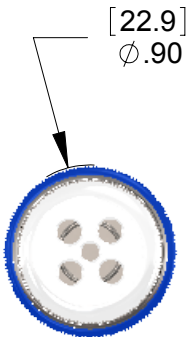

NOTE: WEIGHT = 57 g

ENDCAP FACE LEVEL WHEN INSTALLED ON INSTRUMENT OR BULKHEAD.

SV Xchange

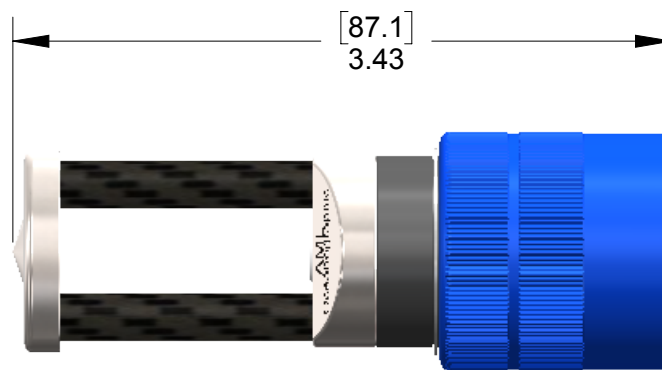
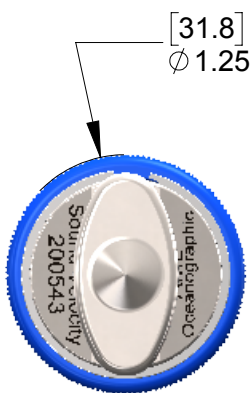

NOTE: WEIGHT = 62 g

T Xchange

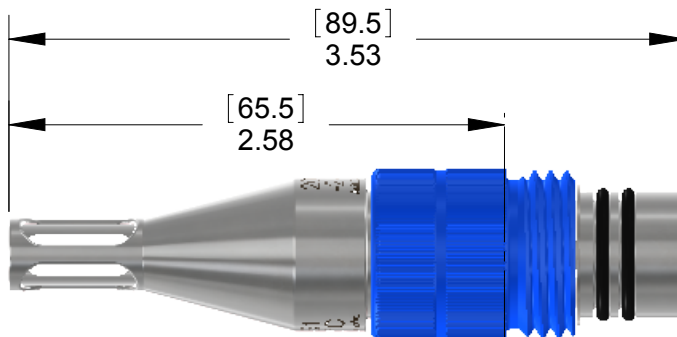
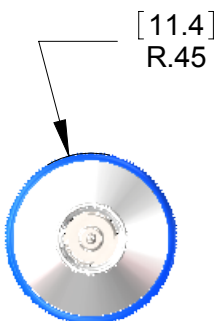

NOTE: WEIGHT = 60 g

ENDCAP FACE LEVEL WHEN INSTALLED ON INSTRUMENT OR BULKHEAD.

NOTE: ALL WEIGHTS MEASURED IN AIR



2071 Malaview Avenue W., Sidney B.C. Canada V8L 5X6 (250) 656 0771 Fax: (250) 655 3655

TOLERANCES:

ANGLES: ± 1°
 FRACTIONS: ± 1/32
 HOLE SIZES: ± 0.005(0.13)
 0.00: ± 0.015(0.38)
 0.000: ± 0.005(0.13)

UNLESS OTHERWISE SPECIFIED:

ORIGINAL SCALE: 1:1
 DIM'S ARE IN INCHES (MM)
 SURFACE FINISH: 63

TITLE:

Xchange Sensor / Device Overview

DRAWN

I.L.

DRAWING NO.:

SNS-GA-03351-D

REV

N/A

AML NO.

N/A

DATE

26FEB2010

MATERIAL:

N/A

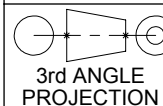

SIZE B

SLD FILE NO.:

N/A

SHEET NO.

Sheet 2 of 3

THE INFORMATION CONTAINED IN THIS DRAWING IS THE SOLE PROPERTY OF AML OCEANOGRAPHIC LTD.
 ANY REPRODUCTION IN PART OR WHOLE WITHOUT THE WRITTEN PERMISSION OF AML OCEANOGRAPHIC LTD IS PROHIBITED

REVISION TABLE

REV	DESCRIPTION	BY	DATE
B	ADDED CTX	ABT	15AUG2015
C	UPDATED TUX & ADDED SENSOR WEIGHTS	LB	27NOV2015
D	UPDATED UVX	MS	11MAY2016

Tu Xchange

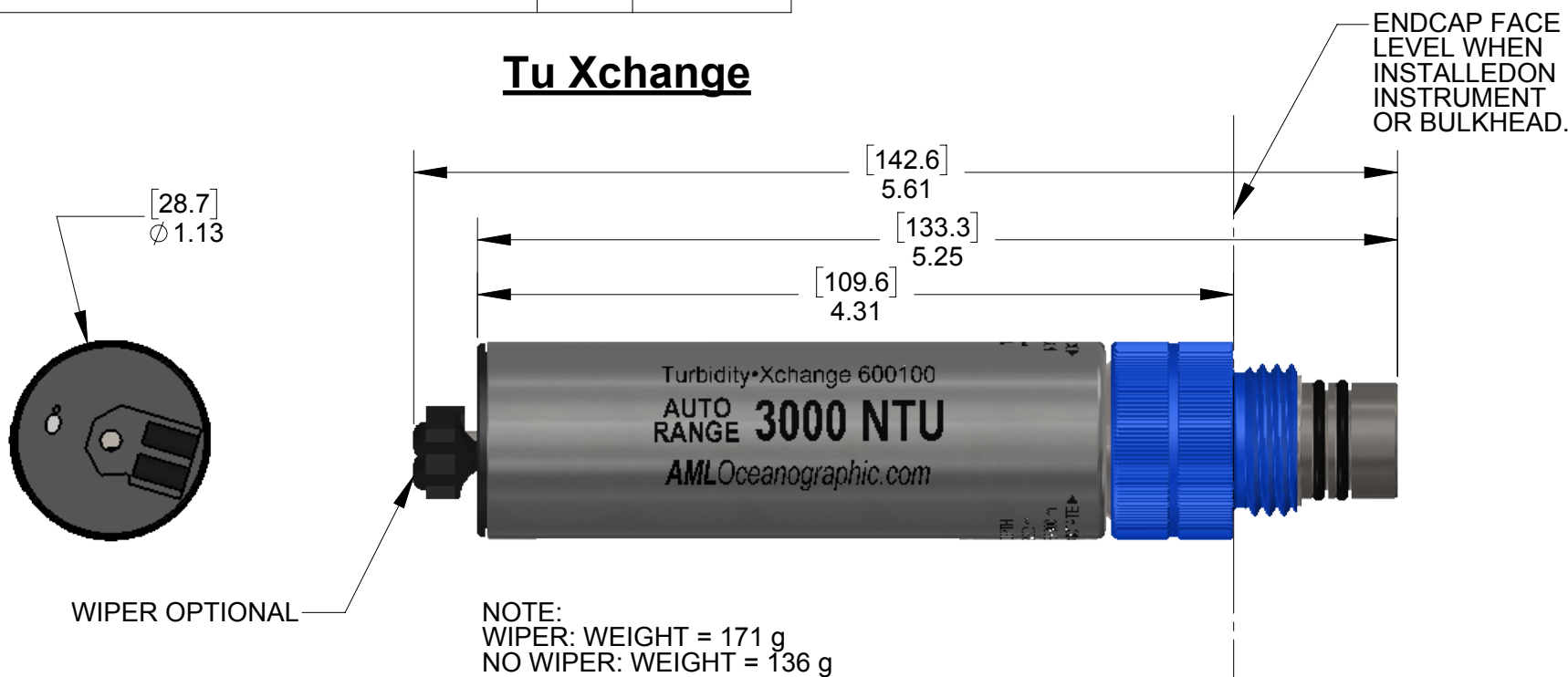

UV Xchange

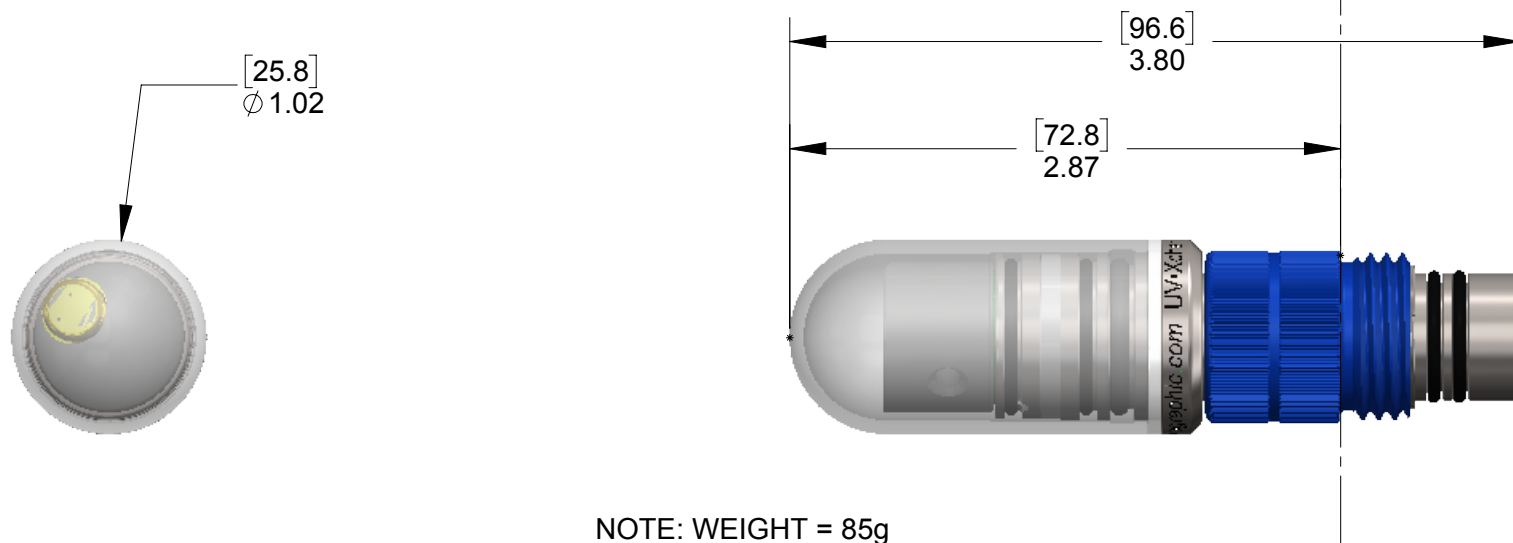
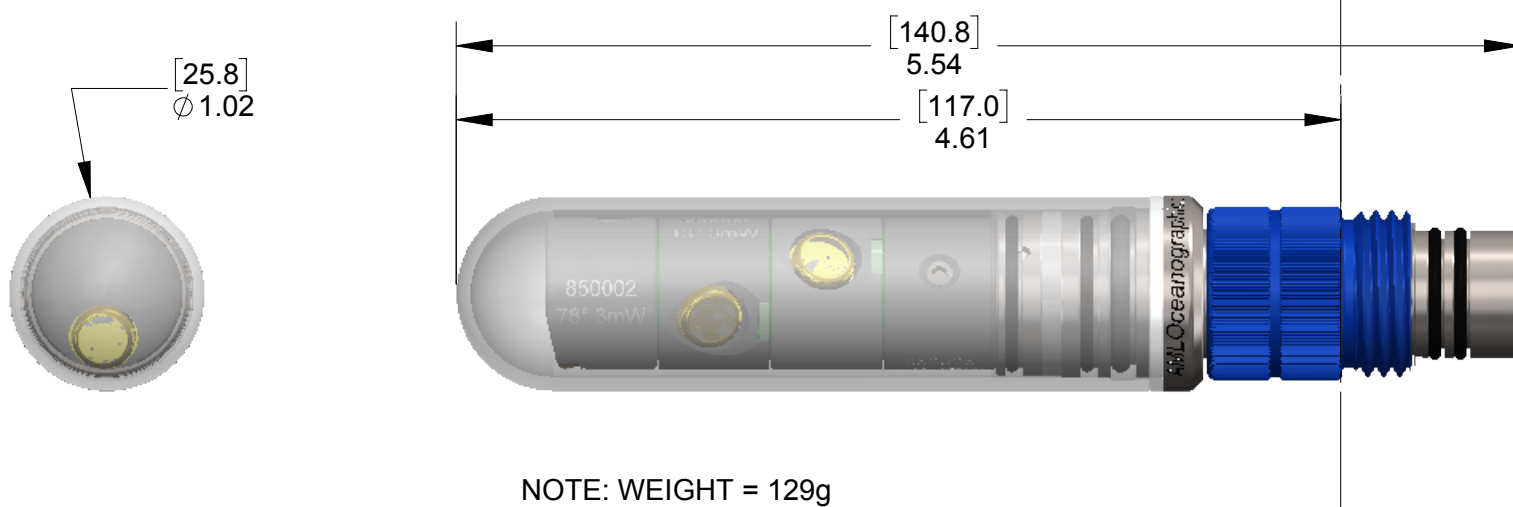

NOTE: ALL WEIGHTS MEASURED IN AIR



2071 Malaview Avenue W., Sidney B.C. Canada V8L 5X6 (250) 656 0771 Fax: (250) 655 3655

TOLERANCES:

ANGLES: ± 1°
 FRACTIONS: ± 1/32
 HOLE SIZES: ± 0.005(0.13)
 0.00: ± 0.015(0.38)
 0.000: ± 0.005(0.13)

UNLESS OTHERWISE SPECIFIED:

ORIGINAL SCALE: 1:1
 DIM'S ARE IN INCHES (MM)
 SURFACE FINISH: 63

TITLE: Turbidity Xchange Sensor			
DRAWN I.L.	DRAWING NO.: SNS-GA-03351-D	REV N/A	AML NO. N/A
DATE 26FEB2010	MATERIAL: N/A		
 3rd ANGLE PROJECTION SIZE B	SLD FILE NO.: N/A	SHEET NO. Sheet 3 of 3	