

Typhoon VMS

Video Measuring System

Features

- High quality camera and laser combination
- Millimetric accuracies
- 470 line resolution, 0.1 lux sensitivity
- Water corrected view port
- Distance and scaling measurements
- User friendly PC software
- 3000m depth rating
- PAL or NTSC options

Applications

- Damage surveys
- Environmental research
- Oceanographic studies



Tritech has developed a laser camera system designed to provide images for capture and subsequent post processing measurements.

The camera has a set of five red laser beams arranged to allow captured images to be calibrated using Tritech's own Video Measuring System (VMS) software.

The Typhoon VMS measures planar targets in the camera's field of view. At its heart is Tritech's Typhoon high resolution colour zoom camera. The red laser diodes surrounding the camera are clearly visible on the operator's monitor. The system software is calibrated by selecting each laser image on the display after which the software allows measurement with high accuracy, within a few minutes of any object in the field of view.

The Typhoon VMS encompasses a 22:1 auto focus zoom lens protected by a 3000m rated hard anodised aluminium housing. Manual focus and zoom may be controlled using analogue signals or via the integrated RS232 interface. It has an angular view in air 47deg (wide) or 2.2deg (telephoto). It has 752 horizontal by 582 vertical sensing pixels.

'The importance of a high quality view port is commonly overlooked in underwater cameras,' said a spokesman. 'The acrylic view port is water corrected, which is the preferred type of lens for underwater applications.'

This view port design reduces the effects of refraction and also removes chromatic aberrations, resulting in a camera that provides a clear and sharp picture during close proximity viewing. This is absolutely essential for accurate subsea metrology.

The camera is available in PAL as standard but NTSC can also be provided. The camera has a minimum scene illumination sensitivity requirement of 0.1Lux, and gives a horizontal resolution output of more than 460 TV lines.

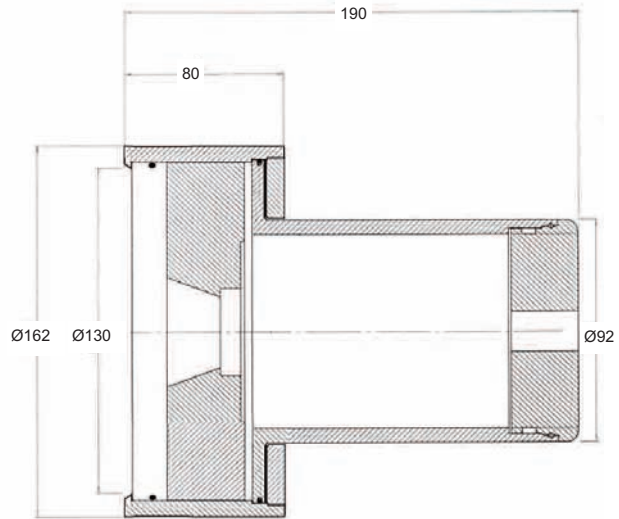
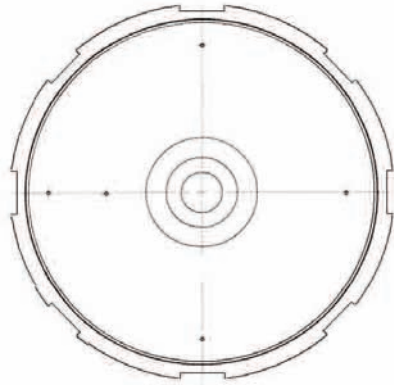

Specifications

Optics

Pick-up element Sensor 1/4inch Interline Transfer CCD Image
Number of pixels 795H x 596V
Number of sensing Pixels 752H x 582V
Scanning 2:1 Interlace PAL CCIR 50hz 625 lines
Lens F1.6 F=4-88mm; High durability
 x 22 Zoom lens (x14 usable). Auto Focus option.
 47° (Wide); 2.2° (Tele)
Angular view in air More than 470 TV lines
Horizontal resolution 0.1Lux (1/2s), 0.2Lux (1/4s)
Minimum illumination

Laser Array

Quantity 5
Class 3R
Wavelength 635nm

Electrical

Connector Burton 1508
Power Nominal 12 -28VDC @ 10W
Video line drive 3 stage amplifier (max 1500m 75 Ohm low loss coax)
Focus & zoom control Analog and RS232 serial controls available

Pressure housing

Mechanical Hard Anodised Aluminium
View port Acrylic, water corrected
Max Diameter 165mm
Length 190mm (excluding connector)
Weight (Air) 3.9Kg
Weight (Water) 1.4Kg

Environmental

Depth rating 3000m
Operating temperature -5 to +40°C
Storage temperature -10 to +50°C
Video frame capture Customer PC or Laptop and frame capture card

VMS software features

File functions File recall and save of processed image
Picture calibration Manual computer aided marking, auto calibration
Measurement Linear to better than 1mm resolution
 Area measurement
 Plan view mode
Picture annotation Measurements overlaid and saved to file
Image enhancement Spot enhancement, edge detection, colour balance, contrast

“This camera is not designed for use in a helium/oxygen atmosphere”

All specifications are subject to change in line with Tritech's policy of continual product development.

Ref: EDS-LSR-003.3



Tritech International Limited

Peregrine Road • Westhill Business Park • Aberdeen
AB32 6JL • United Kingdom

T: +44 (0)1224 744111
F: +44 (0)1224 741771
E-mail: sales@tritech.co.uk
Website: www.tritech.co.uk

Distributed by:

Subsea Technologies Inc.

1323 Price Plaza Drive
Katy, Texas 77449

Tel. : 281 398 5600
Fax : 281 754 4401

Email: sales@subseatechnologies.com
http://www.subseatechnologies.com