



APPLIED ACOUSTICS

Underwater Technology

An AAE Technologies Group Company

1100 Series Operation Manual



Registration No. QU180081a
ISO9001:2015

Applied Acoustic Engineering Ltd

Marine House, Marine Park
Gapton Hall Road
Great Yarmouth NR31 0NB
United Kingdom

T +44(0)1493 440355
F +44(0)1493 440720
E general@appliedacoustics.com
W www.appliedacoustics.com

THIS PAGE IS INTENTIONALLY LEFT BLANK

Revision History

Issue	Change No.	Reason for change	Date
A	-	First Issue, 111X Model	09/10/17
1	2154	Updated to include 2019 design connector endcap Inc other minor changes	16/07/19

Table of Contents

REVISION HISTORY	3
1. INTRODUCTION TO THE 1100 SERIES	6
MINI.....	7
DEPTH TELEMETRY OPTION.....	7
REMOTE TRANSDUCERS.....	8
2. GETTING STARTED	9
HANDLING.....	10
BEACON SUPPORT AND MOUNTING.....	10
3. 1110 BEACON CONNECTOR	11
4. BEACON CHARGING	12
TRICKLE CHARGING.....	13
FAST CHARGING.....	14
1110 FAST CHARGING.....	14
AFTER CHARGING.....	16
5. OPERATING INSTRUCTIONS	17
SWITCHING ON.....	17
BEACON CONFIGURATION.....	17
SERIAL COMMUNICATION.....	17
DEPTH TELEMETRY.....	18
OPERATION WITH EASYTRAK NEXUS 2 SYSTEM (TRANSCIVER MODEL 2686 AND 2780).....	19
SIGMA 2.....	19
SIGMA 2 QUICKSET.....	19
OPERATION WITH EASYTRAK NEXUS 2682 SYSTEM (SPREAD SPECTRUM SS).....	20
OPERATION WITH EASYTRAK SYSTEM.....	21
IXBLUE COMPATIBLE OPERATION.....	21
OPERATION WITH SIMRAD HIPAP.....	22
EXPANDABILITY.....	23
6. OPERATIONAL RANGE	24
7. MAINTENANCE	25
ENDCAP OVERVIEW.....	25
INITIAL INSPECTION.....	26
DISASSEMBLY.....	27
BATTERY REPLACEMENT.....	28
CHECKING ALKALINE BATTERIES.....	28
O-RINGS.....	29
PRESSURE RELIEF VALVE (PRV).....	29
8. END OF LIFE RECYCLING / DISPOSAL	30
9. SPARES	31
CONNECTOR PARTS.....	31
CONNECTOR PARTS.....	31
MISCELLANEOUS.....	31
BATTERY PACKS.....	31
CONNECTOR PARTS.....	31
O-RINGS.....	31
10. FAULT FINDING	32
11. SPECIFICATION	34

12. TRANSPORTATION BY AIR.....	38
NIMH AND ALKALINE BATTERY PACKS	38
13. GENERAL ARRANGEMENT.....	39
1115 / 1115H MINI BEACON.....	39
1119 MINI BEACON	39
1110 MINI BEACON	39
USE WITH REMOTE TRANSDUCERS.....	40
RM15.....	40
RM45.....	41
RM90.....	41

Thank you for choosing Applied Acoustic Engineering as one of your subsea equipment suppliers.
We hope you experience many years of reliable operational use from our products.

If you do encounter any technical issues with any of our products then please don't hesitate to
contact our Technical Team via the following methods.

Tel: +44 (0)1493 440355
Fax: +44 (0)1493 440720

Email: techsupport@appliedacoustics.com



Applied Acoustic Engineering Ltd has made every effort to ensure that the information contained in this manual is correct at time of print. However our policy of continual product improvement means that we cannot assume liability for any errors which may occur.



These written instructions must be followed fully for reliable and safe operation of the equipment that this manual refers to. Applied Acoustic Engineering Ltd cannot be held responsible for any issues arising from the improper use or maintenance of equipment referred to in this manual or failure of the operator to adhere to the instructions laid out in this manual. The user must be familiar with the contents of this manual before use or operation.

1. Introduction to the 1100 Series

The AAE 1100 Series subsea beacons suit a variety of underwater positioning and relocation tasks. This manual covers all standard models in the range.

Beacons can operate as: -

- Acoustically triggered transponder (requires one or two acoustic signals before replying).
- Electrically triggered responder.

These beacons can operate on multiple transmit and receive frequency combinations, defined by AAE and referred to as 'channels', and are compatible with the following systems: -

AAE Easytrak Nexus 2	AAE Digital Spread Spectrum Sigma 2 8 AAE Digital Spread Spectrum Sigma 2 Quick Set channels
AAE Easytrak Nexus	32 AAE Digital Spread Spectrum.
AAE Easytrak	AAE Tone channels.
IxBlue GAPS	4 Interrogate codes plus 00 to 09, 22 & 23 reply codes.
Simrad HPR 400, HiPAP	56 'HiPAP' channels.

A stainless steel selector switch on the connector end cap combines switch on, switch off, and dedicated charge selection plus depending on the model a pressure relief valve.

The beacons bulkhead connector provides responder electrical trigger input, external 24V input, battery charging and RS232 serial communication for beacon configuration.



NOTE: - The term 'beacon' describes either of the above three types of transmitting device.

The following standard models are available: -

Mini

Model 1115	± 45 degrees	194dB SPL	2000m survival depth rating
Model 1115H	± 30 degrees	196dB SPL	2000m survival depth rating
Model 1119	± 90 degrees	188dB SPL	1500m survival depth rating



NOTE: - A published depth rating does not necessarily imply that a particular product will acoustically operate at that depth at all times.

Depth Telemetry Option

1100 Series beacons with a 'D' suffix support depth telemetry. These beacons are identical to the existing 1100 Series models, with the addition of a depth (pressure) transducer and are thus able to reply back to the tracking system with a second telemetry pulse.

The following depth transducers can be supplied as standard: -

- 100 metres
- 300 metres
- 1000 metres
- 2000 metres
- 4000 metres

Other depth transducers can be supplied on request.



NOTE: - Depth beacons are not intended for use at a depth beyond the depth transducers rating. Mechanical damage to the depth transducer will occur.

Remote Transducers

There are also versions of all the above beacons without a transducer fitted, instead an interconnect lead connects to a remote transducer. The following remote transducers are currently available:-

Model RM43	+/-30 degrees
Model RM45	+/-45 degrees
Model RM90	+/-90 degrees

Check with the factory or your area representative for further details.

Applications: - For dedicated tow fish / ROV's where the electronics can be fitted inside and away from potentially damaging, or difficult locations.



Please refer to specifications for Technical Details.



A note on depth ratings: -

A published depth rating does not necessarily imply that a particular product will acoustically operate at that depth at all times. Some units are depth limited to 1000 metres and are not intended for use at a depth beyond 1000 metres. Mechanical damage will occur.

2. Getting Started

On delivery of your beacon, please check the following: -

- Model number
- Depth rating
- Battery type
- Selector switch in the OFF position.

This information can be found on the beacon product label and on the delivery note.

Please ensure that this information is correct and suits your requirements.

Please check the beacon for any transit damage, if any is found, do not use the equipment and return it to your supplier.



Example product label

Your beacon is charged at the factory before dispatch and should arrive fully charged. If the beacon requires charging prior to commissioning, please refer Section 3 Beacon Charging.



NOTE: - If the beacon has been shipped with the selector switch in the ON position, we recommend charging the beacon before deployment.

Handling

Although these beacons are resistant to mechanical vibration and shock, every effort should be made to avoid careless handling. Dropping the beacon could damage the transducer, which contains piezo ceramic material sensitive to mechanical shock.

Beacon Support and Mounting

Beacons must be held securely by means of a mechanical clamp or clamps. The clamping pressure must not overstress the beacon's main tube and the clamp must not contact the beacon electrically if it is metallic. The fixing method must be electrically isolated using rubber or plastic and preferably the clamping fixture should be plastic.



NOTE: - Damage to the beacon's anodising must be avoided at all cost, as this will reduce the operational life of the beacon.

When mounting a beacon, its position should be considered to maximise its operational performance. Beacons need to be mounted so that there is a clear and unobstructed sound path between the transducer and the ship's tracking system. Directional transducers must be 'aimed' at the vessel in a similar way that a torch would be pointed at an object, so that the vessel is 'illuminated' with signal from the beacon. When using highly directional transducers, the towing angle and cable catenary can have a significant effect on the position of the acoustic beam and comprehensive experimentation with positioning is recommended. Also ensure that ROV thruster noise is taken into account when positioning the beacon. We advise that the tracking system is set to low power when tracking at short distances. This is to reduce any multipath that may occur in some environments.



NOTE: - High internal temperatures may occur if the beacon is left out in direct, strong sun light. This may lead to reduced battery operational life span and reduced charge capacity during charging. A 72 degree C thermal fuse is included in the battery pack(s) which will render the beacon inoperative should this temperature be exceeded.



NOTE: - Upon deployment, fit Dummy Connector. Any underwater connections should be greased with O-Lube or Silicone Grease to prevent mating damage occurring and aid water block.

3. 1110 Beacon Connector

1110 beacons MCBH5M 5-pin bulkhead connector provides responder electrical trigger input, external 24V input, battery charging and RS232 serial communication for beacon configuration: -



- PIN 1.** External Trigger Input / RS232 RXD
- PIN 2.** 0VDC Common
- PIN 3.** Fast Charge / RS232 TXD
- PIN 4.** External 24VDC Input / Fast Charge Status
- PIN 5.** Not Connected



WARNING: - Applied Acoustic Engineering cannot be held responsible for injury or damage caused by incorrect use of fuse ratings higher than those recommended above.

PIN 1 functions as both responder trigger input and RS232 serial data input. The beacon can differentiate between a responder trigger and serial data character. Responder trigger specification is a positive going pulse 5V to 25V of duration 2ms to 10ms. Trigger pulses longer than 10ms duration are ignored.

PIN 2 functions as the common 0VDC reference for all electrical signals.

PIN 3 functions as both 30VDC input for fast charging and RS232 serial data output. Serial communication is only possible when the beacon is not being fast charged. Refer Section 4 Beacon Charging.

PIN 4 functions as both external 24VDC input for trickle charging and fast charge status output. Refer Section 4 Beacon Charging.



NOTE: - When powered from a 24VDC external power supply, the beacon will work as either responder or transponder. The transponder circuitry is not switched off when a responder is connected or used



NOTE: - Upon deployment, fit Dummy Connector. Any underwater connections should be greased with O-Lube or Silicone Grease to prevent mating damage occurring and aid water block.

4. Beacon Charging

Your beacon comes with one of the following battery types: -

- Nickel Metal Hydride (NiMH) rechargeable battery pack
- Alkaline **non-rechargeable** battery pack

1110 Series beacons feature an on-board fast charger for a typical 3 to 4 hour charge time (1110 beacons only). **This fast charger is compatible with Nickel Metal Hydride (NiMH) battery type only. 1110 Series beacons can only be charged using the Applied Acoustic 1082 Smart Switch or 1083 Multi Charger.**

The 1100 Series beacon range feature an on-board trickle charger. **This trickle charger is compatible with Nickel Metal Hydride (NiMH) battery type only.** Your beacon can be trickle charged with the 1082 Smart Switch or 1083 Multi Charger, or from a nominal 24VDC power supply.



WARNING: - The sealed beacon must be vented to atmosphere before and after a charge cycle by manually operating the pressure relief valve.



NOTE: - Battery life is quoted in the specification section. Battery life is based on good, recently charged cells. Battery life is quoted as X number of days listening or Y number of replies (operational). Therefore when half the listening life has been used, the number of possible replies has also reduced by half. It is advisable to ensure that operational parameters do not result in the battery pack being discharged before the job is finished! Make sure you have a safety margin!

Trickle Charging

Connecting a nominal 24VDC power supply will trickle charge the beacon battery regardless of selector switch position. Refer Section 3 & Section 4 for beacon connector power supply connection details. Input voltage range is 22VDC to 35VDC with a recommended inline fuse as below: -

Model	Trickle Current	Fuse (MAX)
1110 Mini	80mA	100mA to 200mA



NOTE: - If the inline fuse blows, the beacon should be examined by a competent engineer to establish why the fuse failed. Alternatively, the beacon should be de-commissioned and returned to Applied Acoustic Engineering for evaluation.

Connecting a 24VDC power supply is typical with the beacon fitted to an R.O.V. (Remotely Operated Vehicle) to maximise the beacon's operating life whilst on the R.O.V. It will still be necessary to remove and charge the beacon monthly in order to maintain the beacon battery pack.



NOTE: - The supplied non-shorting dummy connector, complete with locking sleeve, must be fitted when a pigtail is not connected. Always ensure the connector and dummy are greased with O-Lube or Silicon Grease to prevent mating damage occurring and aid water block.

Fast Charging

The beacon selector switch has a dedicated position for fast charging. Set the beacon selector switch to the CHAR position.

Fast charging must take place in a dry environment at normal room temperature (recommended temperature range is between 14°C and 23°C).

Removal of the end cap is not necessary before charging. The sealed beacon must be vented to atmosphere before charging by manually operating the pressure relief valve. If battery gassing should accidentally occur during charging, this gas will vent to atmosphere through the beacon selector switch pressure relief valve. After charging, again the sealed beacon must be vented to atmosphere by manually operating the pressure relief valve.



WARNING: - Do not attempt to charge the beacon if the pressure relief valve is not operational.

The beacon must not be charged if any doubt exists to its operating status. If water ingress is suspected, the beacon should be de-commissioned and returned for evaluation.



WARNING: - Incorrect charging may damage the battery pack, reducing its operational life. Applied Acoustic Engineering cannot be held responsible where incorrect use could prove potentially hazardous.



WARNING: - Do not attempt to recharge the beacon immediately after charging. Attempting to recharge a fully charged battery may reduce the life of the battery and cause damage. Applied Acoustic Engineering cannot be held responsible where incorrect use could prove potentially hazardous.

1110 Fast Charging

The 1110 Series beacons feature an on-board fast charger for a typical 3 to 4 hour charge time (1110 beacons only). A temperature sensor embedded within the battery pack is monitored by the on-board fast charger.



WARNING: - The sealed beacon must be vented to atmosphere before and after a charge cycle by manually operating the pressure relief valve.

Fast charge termination is qualified using both $-\Delta V$ voltage and $\Delta T/\Delta t$ temperature techniques, and can detect various battery faults. Fast charge termination is also qualified by actual charge time, i.e. fast charger time out, and by battery pack temperature.

The Applied Acoustic 1082 Smart Switch & 1083 Multi Charger activate and monitor charging of 1100 Series beacons, displaying to the user charge status information including cause of termination and charge time. Refer 1082 Smart Switch & 1083 Multi Charger manuals for detailed information on operation.

A typical charge activation and termination cycle with the 1082 Smart Switch follows steps listed below: -

1. Manually vent the beacons PRV.
2. Firmly secure beacon connection cable (supplied with 1082 Smart Switch &) between beacon and 1082 Smart Switch.
3. Select 1082 Smart Switch menu item “Fast Charge”.
4. Set beacon selector switch to the CHAR position. Confirm 1082 Smart Switch instruction “Beacon to CHAR”.
5. Confirm 1082 Smart Switch instruction “Plug in DC PSU” by inserting 30VDC power supply unit (supplied with 1082 Smart Switch) into the 1082 Smart Switch and switching on.

If 30VDC power supply unit was already inserted into the 1082 Smart Switch and switched on prior to step 5, this step will be omitted.

6. Confirm 1082 Smart Switch instruction “Start charging”. While charging, the 1082 Smart Switch will display “Charging...”, together with the elapsed charging time.
7. If the pressure relief valve starts to vent water vapour or gas during charging, stop charging immediately and decommission the beacon.
8. If the 1082 Smart Switch indicates “T°c limit!”, the battery pack has exceeded an over temperature or under temperature limit, but the charge cycle continues. Fast charging will pause until the battery pack temperature is within limits, then recommence. This will increase overall charging time. Check the following: -
 - Is the charging environment ambient temperature too hot or too cold?
 - Battery pack temperature will increase toward the end of a fast charge cycle.
9. If the 1082 Smart Switch indicates fast charging has terminated due to “Fault!”, check the following: -
 - Has the beacon pressure relief valve vented? Decommission the beacon.
 - Was the beacon battery pack already fully charged? Attempting to recharge a fully charged battery may reduce the life of the battery and cause damage.
 - Is the beacon battery pack approaching the end of its operational life? Fast charging may have timed out if the battery pack was not charging correctly.
 - None of the above. Return the beacon to Applied Acoustic Engineering for evaluation.

10. If the 1082 Smart Switch indicates fast charging has terminated due to “No status!”, check the following: -
 - Is the beacon selector switch set to the CHAR position?
 - Is the beacon connection cable firmly secure?
 - Is the beacon battery pack open circuit?
 - Is the beacon battery pack exhausted? Set the beacon to the OFF or CHAR position and trickle charge for 10 minutes before attempting to fast charge.
11. If the 1082 Smart Switch indicates fast charging has terminated due to “No DC PSU!”, check the following: -
 - Is the DC power supply unit inserted into the Smart Switch?
 - Check the mains lead and mains supply.
12. After charging has successfully terminated, the 1082 Smart Switch will display “Charged!”, together with overall charging time.
13. On exit from charge termination display, the 1082 Smart Switch will instruct the user to “Vent beacon PRV”. Manually vent beacon’s PRV.

After Charging



WARNING: - The sealed beacon must be vented to atmosphere before and after a charge cycle by manually operating the pressure relief valve.



NOTE: - The supplied MCDC5F non-shorting dummy connector, complete with locking sleeve, must be fitted when a pigtail is not connected.

Making a note of the date of each charge may be helpful in the field to avoid unnecessary future overcharging of the battery pack or beacon charge status with reference to deployment.

The beacon is now ready to use in service.

5. Operating Instructions

Switching On

Switching on is achieved by rotating the beacon selector switch to the ON position.

Beacon Configuration



NOTE: - Beacon must be switched on to be configured.

1100 Series beacons are configured via RS232 serial communication using the 1082 Smart Switch or 1083 Multi Charger. Configuration options includes channel selection, depth telemetry transmission on/off (if available), battery pack voltage monitoring, etc. Refer 1082 Smart Switch & 1083 Multi Charger manuals for detailed information on operation.

Serial Communication

The beacon supports RS232 serial communications at 9600 baud only. Serial communication is only possible when the beacon is switched on. Serial communication is not possible when the beacon is switched off or during fast charge. Refer Section 10 Specification for detailed serial communication specification.

Depth Telemetry

1100 Series beacons with a 'D' suffix support depth telemetry. These beacons are identical to the existing 1100 Series beacons, except they are fitted with pressure (depth) transducers and are thus able to reply back to the tracking system with the depth.

Depth telemetry transmission is selected ON (enabled) or OFF (disabled) using the 1082 Smart Switch or 1083 Multi Charger. Select beacon configuration menu option followed by "Depth Status".



NOTE: - For non-'D' suffix beacons, depth telemetry cannot be selected ON (enabled).

Depending on the selected mode of operation the depth data is either sent in a data telegram or a time delay between the first transmitted pulse and second transmitted pulse. This is automatically switched depending on selected channel.

For AAE Easytrak Nexus Sigma 2 Spread Spectrum operation the depth information is transmitted using a data telegram.

For AAE Easytrak Tone, an initial delay of 100ms is used to convey 0 metres depth and a maximum delay of 900ms is used to convey maximum depth. This depth is written on the case of the beacon. It follows that the maximum interrogate rate should be limited to 2 seconds in most instances.

For Simrad HPR / HiPAP operation the 0 metres depth delay is 125ms. The depth reply delay is 0.5ms per metre for HPR300 and 1ms per metre for HPR400 / HiPAP compatibility.

Operation with Easytrak Nexus 2 system (Transceiver Model 2686 and 2780)

Sigma 2

Sigma2 Channel configuration consists of a Wake-Up Tone (WUT), Interrogate Code (IC), Reply Code (RC) and Turn-Around-Time Extension (TATX) in sequence before selecting the confirmed configuration

WUT + IC + RC + TATX

Wake up (WUT) ID 0-7, total of 8

Interrogate Code (IC) 00 to14, total of 15 codes

Reply Code (RC) 00 to 14, total of 15 codes

Turn-Around-Time Extension (TATX): Default extension = 0ms.

The Sigma 2 framework provides configuration options for common interrogate of an array of up to 10 1110 beacons for high speed positional updates. The TATX extension is applicable to this functionality.

Sigma 2 Quickset

Beacon Channel ID	Nexus 2 Channel ID	Transponder TAT (ms)	Responder TAT (ms)	Description
AA	Sigma 2 Quick Set 1	75	75	AAE Sigma 2, Quick Set
AB	Sigma 2 Quick Set 2	75	75	AAE Sigma 2, Quick Set
AC	Sigma 2 Quick Set 3	75	75	AAE Sigma 2, Quick Set
AD	Sigma 2 Quick Set 4	75	75	AAE Sigma 2, Quick Set
AE	Sigma 2 Quick Set 5	75	75	AAE Sigma 2, Quick Set
AF	Sigma 2 Quick Set 6	75	75	AAE Sigma 2, Quick Set
BC	Sigma 2 Quick Set 7	75	75	AAE Sigma 2, Quick Set
BD	Sigma 2 Quick Set 8	75	75	AAE Sigma 2, Quick Set



NOTE: - Depth Telemetry is not supported in Quickset mode.

Operation with Easytrak Nexus 2682 system (Spread Spectrum SS)

Channel	ID	Transponder TAT (ms)	Responder TAT (ms)	Description
E0	SS CH 0	100	100	AAE Spread Spectrum
E1	SS CH 1	100	100	AAE Spread Spectrum
E2	SS CH 2	100	100	AAE Spread Spectrum
E3	SS CH 3	100	100	AAE Spread Spectrum
E4	SS CH 4	100	100	AAE Spread Spectrum
E5	SS CH 5	100	100	AAE Spread Spectrum
E6	SS CH 6	100	100	AAE Spread Spectrum
E7	SS CH 7	100	100	AAE Spread Spectrum
E8	SS CH 8	100	100	AAE Spread Spectrum
E9	SS CH 9	100	100	AAE Spread Spectrum
EA	SS CH 10	100	100	AAE Spread Spectrum
EB	SS CH 11	100	100	AAE Spread Spectrum
EC	SS CH 12	100	100	AAE Spread Spectrum
ED	SS CH 13	100	100	AAE Spread Spectrum
EE	SS CH 14	100	100	AAE Spread Spectrum
EF	SS CH 15	100	100	AAE Spread Spectrum
F0	SS CH 16	100	100	AAE Spread Spectrum
F1	SS CH 17	100	100	AAE Spread Spectrum
F2	SS CH 18	100	100	AAE Spread Spectrum
F3	SS CH 19	100	100	AAE Spread Spectrum
F4	SS CH 20	100	100	AAE Spread Spectrum
F5	SS CH 21	100	100	AAE Spread Spectrum
F6	SS CH 22	100	100	AAE Spread Spectrum
F7	SS CH 23	100	100	AAE Spread Spectrum
F8	SS CH 24	100	100	AAE Spread Spectrum
F9	SS CH 25	100	100	AAE Spread Spectrum
FA	SS CH 26	100	100	AAE Spread Spectrum
FB	SS CH 27	100	100	AAE Spread Spectrum
FC	SS CH 28	100	100	AAE Spread Spectrum
FD	SS CH 29	100	100	AAE Spread Spectrum
FE	SS CH 30	100	100	AAE Spread Spectrum
FF	SS CH 31	100	100	AAE Spread Spectrum

Digital Depth telemetry available if depth sensor fitted

Operation with Easytrak system

Channel	RXF1 (Hz)	RXF2 (Hz)	TXF1 (Hz)	TXF2 (Hz)*	Transponder TAT (ms)	Responder TAT (ms)	Pulse Width (ms)
A0	17500	-	30000	29000	30	30	2
A1	18500	-	28000	27000	30	30	2
A2	19500	-	26000	25000	30	30	2
A3	20500	-	29000	28000	30	30	2
A4	21500	-	27000	26000	30	30	2
A5	22500	-	30000	29000	30	30	2
A6	18000	20000	27000	26000	60	30	2
A7	18000	21000	28000	27000	60	30	2
A8	18000	22000	30000	29000	60	30	2
A9	18000	23000	29000	28000	60	30	2
B0	20000	18000	30000	29000	60	30	2
B1	20000	21000	29000	28000	60	30	2
B2	20000	22000	28000	27000	60	30	2
B3	21000	18000	27000	26000	60	30	2
B4	21000	20000	26000	25000	60	30	2
B5	21000	22000	28000	27000	60	30	2
B6	21000	23000	30000	29000	60	30	2
B7	22000	18000	26000	25000	60	30	2

*Depth telemetry transponders only.

iXBlue compatible operation

Firmware and option permitting, these beacons are iXBlue compatible as detailed below: -

The Interrogate Frequency is selectable 19.5KHz, 20KHz, 20.5KHz, 21.5kHz.

The Reply Code is selectable from 00 to 09, 22 & 23 for a total of 12 codes.

Turn-Around-Time is selectable from 20 milliseconds to 200 milliseconds in 1 millisecond steps.

Operation with Simrad HiPAP

Simrad's HiPAP systems use 56 channels listed below and transmit a double interrogation pulse.

Channel	RXF1 (Hz)	RXF2 (Hz)	TXF1 (Hz)	TXF2 (Hz)*	Transponder TAT (ms)	Responder TAT (ms)	Pulse Width (ms)
12	21000	21500	29250	29750	60	30	10
13	21000	22000	29750	30250	60	30	10
14	21000	22500	30250	28750	60	30	10
15	21000	23000	30750	27250	60	30	10
16	21000	23500	27250	27750	60	30	10
17	21000	24000	27750	28250	60	30	10
18	21000	24500	28250	30750	60	30	10
21	21500	21000	28500	29000	60	30	10
23	21500	22000	29500	30000	60	30	10
24	21500	22500	30000	28500	60	30	10
25	21500	23000	30500	27000	60	30	10
26	21500	23500	27000	27500	60	30	10
27	21500	24000	27500	28000	60	30	10
28	21500	24500	28000	30500	60	30	10
31	22000	21000	28750	29250	60	30	10
32	22000	21500	29250	29750	60	30	10
34	22000	22500	30250	28750	60	30	10
35	22000	23000	30750	27250	60	30	10
36	22000	23500	27250	27750	60	30	10
37	22000	24000	27750	28250	60	30	10
38	22000	24500	28250	30750	60	30	10
41	22500	21000	28500	29000	60	30	10
42	22500	21500	29000	29500	60	30	10
43	22500	22000	29500	30000	60	30	10
45	22500	23000	30500	27000	60	30	10
46	22500	23500	27000	27500	60	30	10
47	22500	24000	27500	28000	60	30	10
48	22500	24500	28000	30500	60	30	10
51	23000	21000	28750	29250	60	30	10
52	23000	21500	29250	29750	60	30	10
53	23000	22000	29750	30250	60	30	10
54	23000	22500	30250	28750	60	30	10
56	23000	23500	27250	27750	60	30	10
57	23000	24000	27750	28250	60	30	10
58	23000	24500	28250	30750	60	30	10
61	23500	21000	28500	29000	60	30	10
62	23500	21500	29000	29500	60	30	10
63	23500	22000	29500	30000	60	30	10
64	23500	22500	30000	28500	60	30	10
65	23500	23000	30500	27000	60	30	10
67	23500	24000	27500	28000	60	30	10
68	23500	24500	28000	30500	60	30	10

Operation with Simrad HiPAP cont.

Channel	RXF1 (Hz)	RXF2 (Hz)	TXF1 (Hz)	TXF2 (Hz)*	Transponder TAT (ms)	Responder TAT (ms)	Pulse Width (ms)
71	24000	21000	28750	29250	60	30	10
72	24000	21500	29250	29750	60	30	10
73	24000	22000	29750	30250	60	30	10
74	24000	22500	30250	28750	60	30	10
75	24000	23000	30750	27250	60	30	10
76	24000	23500	27250	27750	60	30	10
78	24000	24500	28250	30750	60	30	10
81	24500	21000	28500	29000	60	30	10
82	24500	21500	29000	29500	60	30	10
83	24500	22000	29500	30000	60	30	10
84	24500	22500	30000	28500	60	30	10
85	24500	23000	30500	27000	60	30	10
86	24500	23500	27000	27500	60	30	10
87	24500	24000	27500	28000	60	30	10

*Depth telemetry transponders only.

1100 Series beacons comply with 'B' Channels as shown on the monitor screen e.g. "B24" for our channel 24. Please note that the HiPAP system is not able to operate with the 'old' HPR channels 11/22/33/44/55 and 1 to 9.

Expandability

There are a number of channels that have not been defined. If your company has the need for additional channels for any reason, please contact us and we may be able to help.

6. Operational Range

This is the most commonly asked question and there is no direct answer. Acoustic conditions, tracking system type and quality of installation all have an effect upon range. Experience with the vessel and system in question is the governing factor.

7. Maintenance

Endcap Overview

1110 Mini Series Connector End Cap (Pre 2019 design)

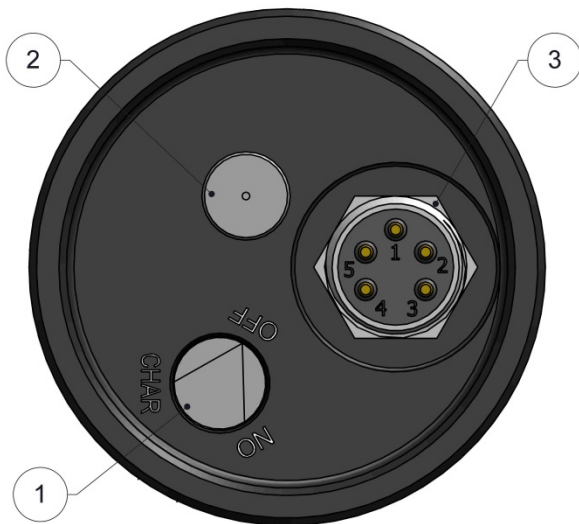

1. ON/OFF/CHARGE Actuator inc Pressure Relief
2. Depth Sensor (if applicable)
3. MCBH5MSS Bulkhead Connector

1110 Mini Series Connector End Cap (2019 design)

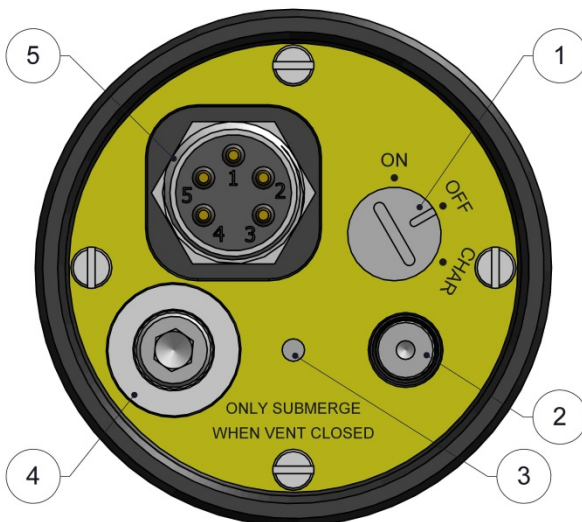

1. ON/OFF/CHARGE Actuator
2. Pressure Relief Valve
3. Depth Sensor (if applicable)
4. Sacrificial Anode
5. MCBH5MSS Bulkhead Connector

Initial Inspection

Inspect the beacon for obvious signs of mechanical damage or corrosion prior to attempting disassembly.

- Is there damage to, or corrosion of, the beacons anodised exterior?
- **PRE 2019 DESIGN ONLY** Is the Pressure Relief Valve (Switch Actuator) proud of the lower end-cap, indicated (as shown below) by the red indicator ring? This indicates that there is a build-up of internal pressure, manually vent PRV immediately by simply pulling out the PRV actuator until you can audibly hear the internal air pressure releasing.

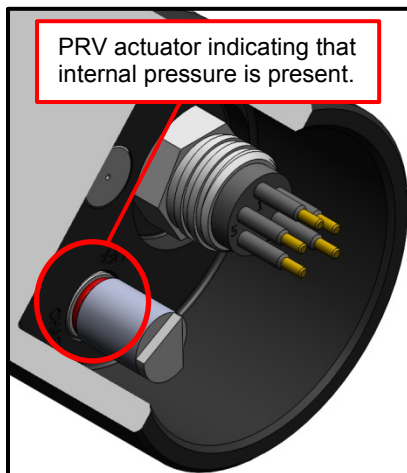

- **2019 DESIGN ONLY** Is the Pressure Relief Valve proud of the end-cap cover plate? This indicates that there is a build-up of internal pressure, manually vent PRV immediately by simply fitting a M3 threaded screw and pulling out the PRV actuator until you can audibly hear the internal air pressure releasing.

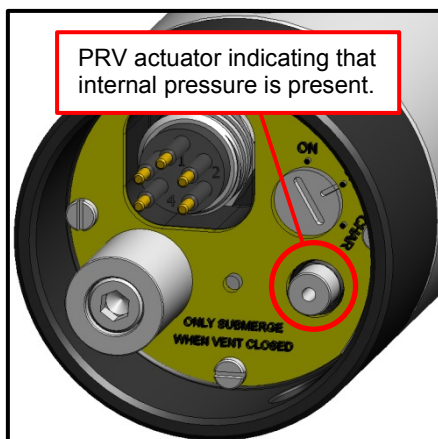

- Is the bulkhead connector corroded? This could cause problems charging the beacon, operating on external power, using responder trigger or configuring the beacon.
- Is the beacon hot / warm to touch (above 40°C)? Has the beacon been exposed to high temperatures? Has the beacon been over charged? Manually vent PRV immediately.
- Is the bulkhead connector secure on the connector end cap? Check for rotation of the connector and correct during disassembly if movement is detected.



WARNING: - IF YOU SUSPECT THE BEACON HAS FLOODED, DO NOT ATTEMPT TO CHARGE OR OPERATE THE BEACON. The beacon must be carefully examined before it can resume service. Even the smallest amount of contamination can seriously destabilise the battery cells, reducing operational life and leading to internal pressure build up.

Disassembly



WARNING: - Vent any internal pressure by manually actuating the pressure relief valve (PRV). During pressure housing disassembly, orientate end caps away from the engineer. Always assume that there is pressure internally.



NOTE: - Take appropriate anti-static precautions during disassembly to prevent damage to beacon electronics. In addition, when working internally, ensure the large storage capacitor is discharged.

- Disconnect all cables and ensure beacon is switched off by rotating the beacon selector switch to the OFF position.
- Manually vent the PRV switch actuator to atmosphere to equalise any internal pressure build up.
- 1110 Mini Series
 - Remove the four white plastic screws from the beacon connector end.
 - Remove the connector end cap carefully from the housing, ensuring it does not drag on the sealing face of the tube.
 - Disconnect the internal interconnecting cable from the connector end cap and remove the mechanical safety strap.
 - Remove the four white plastic screws from the beacon transducer end.
 - Remove the transducer end cap and electronics assembly from the housing, ensuring it does not drag on the sealing face of the tube.
- Check the O-rings and clean or replace them if necessary before re-assembly. During re-assembly, ensure all seals and sealing faces are undamaged and contamination free, with a light covering of O-ring lubricant.
- Reassembly is the reverse of the above. During reassembly, do not over-tighten the white plastic screws (where fitted).

Contact Applied Acoustic Engineering for spares and assistance.



NOTE: - The pressure relief valve is a non-serviceable item, if it is faulty or mechanically damaged then the beacon should be returned to the factory or service centre for replacement.

Battery Replacement

In due course, rechargeable batteries will require replacement and this can be achieved quite simply with the 1100 Series. We recommend a maximum 3 year life for re-chargeable packs.



NOTE: - Replace battery packs with Applied Acoustic Engineering battery packs only. Applied Acoustic Engineering battery packs are constructed with numerous safety features for long operational life. Refer Section 9 Spares for battery pack part numbers. Applied Acoustic Engineering cannot be held responsible for damage or injury caused by incorrect battery replacement or fitment by non-Applied Acoustic Engineering personnel.

Nominal battery voltages are as follows: -

1110 Mini Series NiMH Battery Pack	15 cells at 1.2V / cell = 18V.
1110 Mini Series Alkaline Battery Pack	12 cells at 1.5V / cell = 18V.



NOTE: - Ensure that replacement battery packs are the same as the original type and complete the battery pack information label. Refer to the label on the old pack.

Checking Alkaline Batteries

Estimating the remaining life of an alkaline battery pack is not precise and the following advise should only be regarded as a guide.

Nominal voltage is 1.5V per cell. We recommend connecting a 680 ohm 1 watt resistor to the battery pack, then wait for 30 seconds and measure the battery pack voltage under load across the resistor. A new pack will measure approximately 21V under load. We would consider a battery pack to require replacement if it measures 17V or less. Using a flat (straight line) discharge curve between 21V and 17V would indicate that at 19V, the battery's energy has depleted by 50%. We do not recommend using battery pack below 17V.



NOTE: - Do not use alkaline in equipment designed to operate with rechargeable batteries as this could lead to an explosion and injury. Applied Acoustic Engineering cannot be held responsible for damage or injury caused by incorrect battery replacement or fitment by non Applied Acoustic Engineering personnel.

O-Rings

It is recommended that the O-rings are inspected annually for integrity and foreign matter.

O-ring seals that are exposed to high pressure cycles (working depths in excess of 1500 metres) should be changed annually to ensure operational reliability.

Typical O-ring guidelines are to check their integrity and are clean, ensure all seals and sealing faces are undamaged and contamination free, with a light covering of O-ring lubricant. Contact Applied Acoustic Engineering for spares and assistance.

Pressure Relief Valve (PRV)

As the pressure relief valve is a user accessible safety device on the 1100 series beacons, the operator should, during routine use, visually inspect the condition of the PRV actuator for debris or reduction in O-ring lubrication. Any interim cleaning and lubrication required should be performed by the operator to maintain the integrity of the valve. Failure to maintain the valve throughout life cycle voids warranty and compromises safety.

Typical O-ring guidelines are to check their integrity and are clean, ensure all seals and sealing faces are undamaged and contamination free, with a light covering of O-ring lubricant. Contact Applied Acoustic Engineering for spares and assistance.

Applied Acoustic Engineering strongly recommends that all pressure relief valves are annually tested for safe reliable operation, as a minimum. This is done on a service-repair or exchange scheme at the factory. Pressure relief valves which are not serviced may become contaminated with marine growth or debris, leading to water ingress or pressurisation of the beacon housing.



Inspect pressure relief valve during routine operation, perform interim maintenance or cleaning as required to ensure safe operation.



NOTE: - See Page 33 for PRV location.

8. End of Life Recycling / Disposal



Within the EU all electronic components and batteries must be taken for separate collection at the end of their working life under EU WEEE directives. Applied Acoustics as a manufacturer within the EU will responsibly dispose of any returned end of life Applied Acoustics components / batteries through a registered WEEE scheme. In order to prevent uncontrolled waste disposal and promote re-cycling please return any end of life Applied Acoustic components postage paid by sender to our UK head office. Please contact Tech Support for a RMA number prior to shipping.

9. Spares

The following beacon spares are available from stock. Please also reference the model number and serial number of the unit you require spares for.

Note that this page contains parts for both variants of endcap design (pre 2019 & 2019 design). Refer to page 25 to help identify which variant you have.

Connector endcap (Pre 2019 design)

Connector Parts

MCBH5MSS bulkhead connector Part Number ECN050372

Connector endcap (2019 design)

Connector Parts

MCBH5MSS bulkhead connector assembly Part Number BCN-1110-4001

Miscellaneous

Cover plate Part Number BCN-1110-2008
Sacrificial anode Part Number BCN-1110-2014

The following spares are applicable for both variants.

Battery Packs

NiMH battery pack Part Number BCN-1010-3000
Alkaline battery pack Part Number BCN-1010-3001

Connector Parts

MCDC5F non-shorting dummy connector (with locking sleeve) Part Number ECN050482

O-Rings

1010 Mini Series Body Kit (all kits include O-ring lubricant)

10. Fault Finding

It doesn't work, what can we do?

Most instances of failure are due to mechanical damage or user error but the possibility of component failure is always there.

Did it ever work?

If the answer is yes, either the battery is not charged or the beacon is faulty. Look for mechanical damage and also check for damage to the charging connector.



WARNING: - If there are any signs of mechanical damage which could result in water ingress, do not charge the beacon. Vent any internal pressure by manually operating the pressure relief valve. Return the beacon to Applied Acoustic Engineering for repair.



WARNING: - If the pressure relief valve has vented water or vapour during charging, stop charging and decommission the beacon. Return the beacon to Applied Acoustic Engineering for repair.

If the beacon has been over-charged, do not use. Replace the battery pack or return the beacon to Applied Acoustic Engineering.

If there are no signs of mechanical damage, try charging the beacon.

Check the beacon with the 1082 Smart Switch or 1083 Multi Charger responder test function. If the beacon responds, the battery and the transmitter are functional.

Is the beacon configured correctly?

Try turning the beacon off for minimum of 1 minute then turning beacon back on and retry operation.

If these tests do not help or resolve the problem, contact Applied Acoustic Engineering immediately for technical assistance.

Is performance poor?

If the answer is yes, please consider the following: -

- If you have a similar model, is the performance the same? This will identify if there is just one faulty beacon.
- Are you out of range? Again check with a similar model. Maybe a higher powered beacon is required.
- Is multipath present? Try slowing down the interrogation rate.
- Are you within the beam pattern of the transducer? If the signal from the beacon is not illuminating the vessel, then it cannot be tracked. If you are tow fish tracking, cable catenary has been known to cause problems occasionally, the signal could transmit at the wrong angle and miss the vessel.
- If you are tow fish tracking and there is a large water temperature change between the surface of the water and the beacon position, you may be experiencing severe ray bending.
- Are results different to another model? You may be comparing different models and different specifications.
- Check on a different channel (frequency) to see if performance changes.

If you can't find a solution, contact Applied Acoustic Engineering immediately for technical assistance.

11. Specification

Model Types

Refer to section 13 for additional dimensions

	Beam Pattern	SPL	Diameter	Length	Survival Depth	Weight Air/Water
Model 1115*	± 45°	194dB	74mm	410mm	2000m	3.08kg / 1.46kg
Model 1115H	± 30°	196dB	74mm	410mm	2000m	3.08kg / 1.46kg
Model 1119*	± 90°	188dB	74mm	395mm	1500m	2.88kg / 1.38kg

*includes 'D' suffix models.

Physical

Housing Material	Hard anodised aluminium
External Connector	MCBH5MSS 5-way bulkhead plug
External Switch	<p>Combined selector switch / pressure relief valve. Stainless-steel freely rotating with 3 positions (1110 pre-2019 design). Indexed selector switch / separate pressure relief valve (1110).</p> <p>ON Switch on beacon OFF Switch off beacon CHAR Charge beacon</p>
Operating Temperature	-5°C to 30°C
Storage Temperature	<p>0°C to 45°C Battery pack maximum storage temperature is 55°C Temperatures above 70°C will render the battery pack unserviceable.</p>

Although unlikely, published specifications are subject to change. Please consult the factory if a particular specification is critical. Changes to the existing design are possible - please consult the factory for information.

CE. These units conform to the European directive 89/336/EEC for electromagnetic compatibility when used in the proper manner.

Electrical (All Models)

AAE Sigma 2	Wake up (WUT) ID 0-7, total of 8 Interrogate Code (IC) 00 to 14, total of 15 codes Reply Code (RC) 00 to 14, total of 15 codes Turn-Around-Time: 75ms to 2000ms in 1ms steps
AAE Sigma 2 Quick-Set	Quickset schemes total of 8 pre-set schemes
AAE 'Channels'	AAE Nexus Sigma 1 32 AAE Easytrak 18 HPR400 56
AAE 'Channels' Spare	Yes
AAE Turn-Around-Time	15ms / 30ms / 60ms / 75ms / 100ms / User Depending on AAE 'channel' selected
iXBlue	Compatible, firmware permitting Interrogate Frequency 19.5kHz to 21.5kHz in 0.5kHz steps. Reply Code 00 to 09, 22 & 23 for a total of 12 codes. Turn-Around-Time 20ms to 200ms in 1ms steps.
Responder Trigger	Positive going logic pulse 6V to 25V of duration 2ms to 10ms
Serial Communication	RS232 compliant 9600 baud rate 8 data bits 1 stop bit No parity No flow control
Power Supply	NiMH rechargeable battery pack (3 off for 1050) Alkaline non-rechargeable battery pack (3 off for 1050) External 22VDC to 35VDC (with recommended fuse)

Battery Life*	1110 Mini Series 60 days listening or Model 1119 150 hours at 1 reply per second Model 1115 150 hours at 1 reply per second Model 1115H 100 hours at 1 reply per second
----------------------	---

*Operation Battery life quoted in AAE Mode, operational life reduced by 60% when in other operational modes.

AAE Charge	1110 on-board charger. 1110 Mini 3 to 4 hour typical fast charge - ΔV voltage and $\Delta T/\Delta t$ temperature charge termination techniques Activated and monitored via 1082 Smart Switch or 1083 Multicharger 1110 Mini: 667mA \pm 30mA @ 30VDC
-------------------	--

Trickle Charge	1110 Mini: 80mA \pm 2mA* @ 22VDC to 35VDC
-----------------------	---

* Max charge current dependent on battery charge status

Although unlikely, published specifications are subject to change. Please consult the factory if a particular specification is critical. Changes to the existing design are possible - please consult the factory for information.

CE. These units conform to the European directive 89/336/EEC for electromagnetic compatibility when used in the proper manner.

Depth Models (Suffix 'D')

Depth Span	As written on housing label
Depth Rating	Twice depth span or 1500 metres, whichever is less
Number of Replies	As non-depth model when depth transmission is disabled 48% of the above when depth transmission is enabled
Depth Transducers	100 metres 300 metres 1000 metres 2000 metres 4000 metres

Although unlikely, published specifications are subject to change. Please consult the factory if a particular specification is critical. Changes to the existing design are possible - please consult the factory for information.

Remote Transducer Models

There are also versions of all the above beacons *without a transducer fitted*, instead an interconnect lead connects the electronics bottle to a remote transducer. The following transducers are currently available:-

Model RM15 +/-15 degrees
Size 125mm diameter
206dB with 1130 Midi Series
208dB with 1160 Fatboy Series
Weight in Air / Water: 5.85Kg / 3.4Kg

Model RM43 +/- 30 degrees
Frequency 27 – 33 kHz
Size 75 mm diameter
196dB with 1110 Mini Series

Model RM45 +/-45 degrees
Size 75 mm diameter x 160 mm long.
200dB with 1130 Midi Series
203dB with 1160 Fatboy Series
Weight in Air / Water: 1.8Kg / 1.0Kg

Model RM90 +/-90 degrees
Size 75 mm diameter x 160 mm long
187dB with 1110 Mini Series
190dB with 1130 Midi Series
Weight in Air / Water: 1.8Kg / 1.0Kg

Check with the factory or your area representative for further details.

CE These units conform to the European directive 89/336/EEC for electromagnetic compatibility when used in the proper manner.

12. Transportation by Air

All equipment should be switched off prior to air transportation. Switching off is achieved by rotating the beacon selector switch to the OFF position.

NiMH and Alkaline Battery Packs

These battery packs are **not** classified as dangerous goods for transportation by air. Any paperwork accompanying beacons that use these battery types should state this clearly.

13. General Arrangement

1115 / 1115H Mini Beacon

Inc protective sleeve and cage

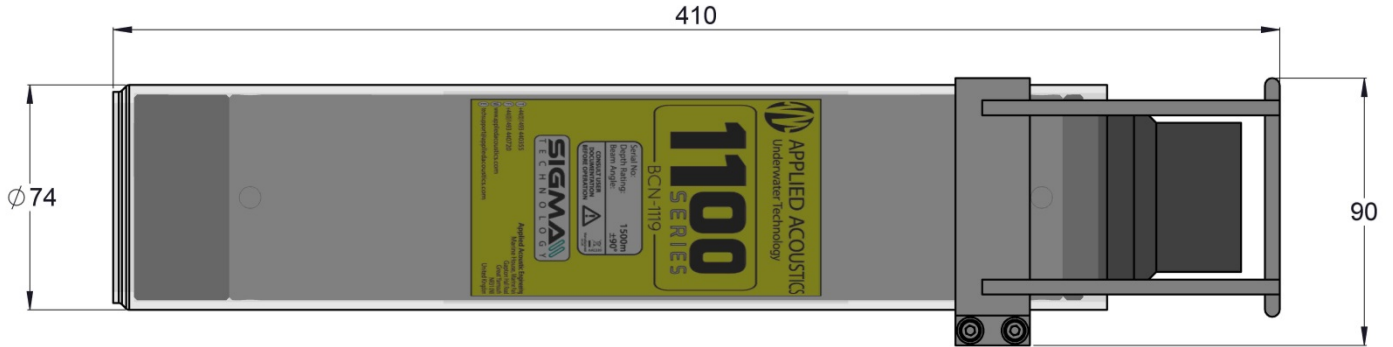

1119 Mini Beacon

Inc protective sleeve and cage

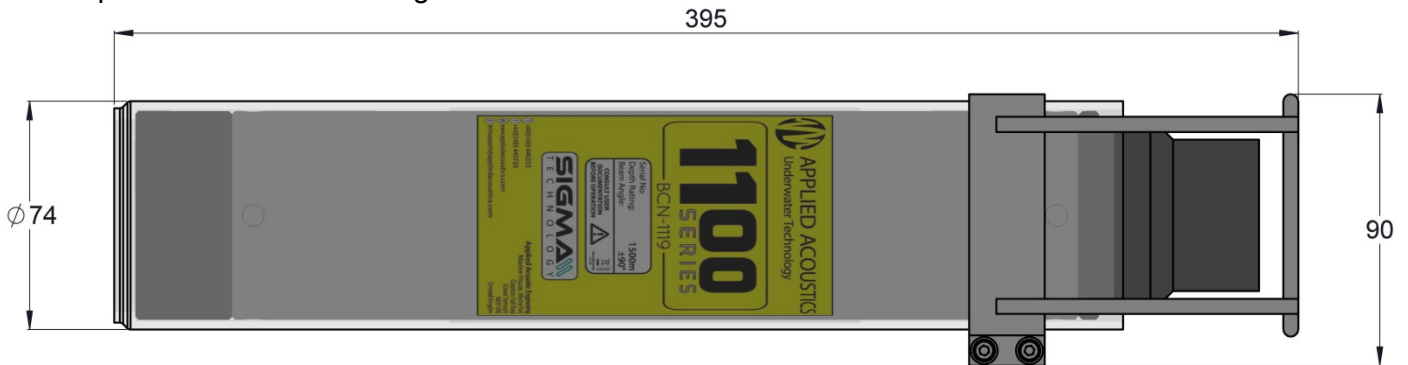

1110 Mini Beacon

Model details to be confirmed, please contact Applied Acoustics



NOTE: - Protective sleeves are dip moulded and are subject to a +/-2mm Tolerance

Use with Remote Transducers

Some beacons can be fitted with remote transducers. This can make installation easier in some instances. The three transducers all connect to the electronics with the same cable:-

Cable Type: 4-4 I/C Lead
Connectors: IL-4-FS and IL-4-MP
Connections:

Free Plug	Free Socket
------------------	--------------------

Pin 1	Pin 1
Pin 2	Pin 2
Pin 3	Pin 3
Pin 4	Pin 4

The cable length is a standard 1.5 metres minimum (typically 1.8 metres). We would not usually recommend that this length be increased to any great extent. As the cable is not screened, it is advisable to ensure that it is not secured close to any electric motors or electrical equipment. We can supply shorter cable lengths to order.

RM15

This has a highly directional transducer beam pattern of +/- 15 degrees and is used for deep water work (ROV's Ploughs etc.). The black potted face is the radiating surface which must be positioned on the vehicle to point directly towards the tracking system. Because of the directional nature of this product, it is unlikely that it will be used for tow fish / ROTV tracking.

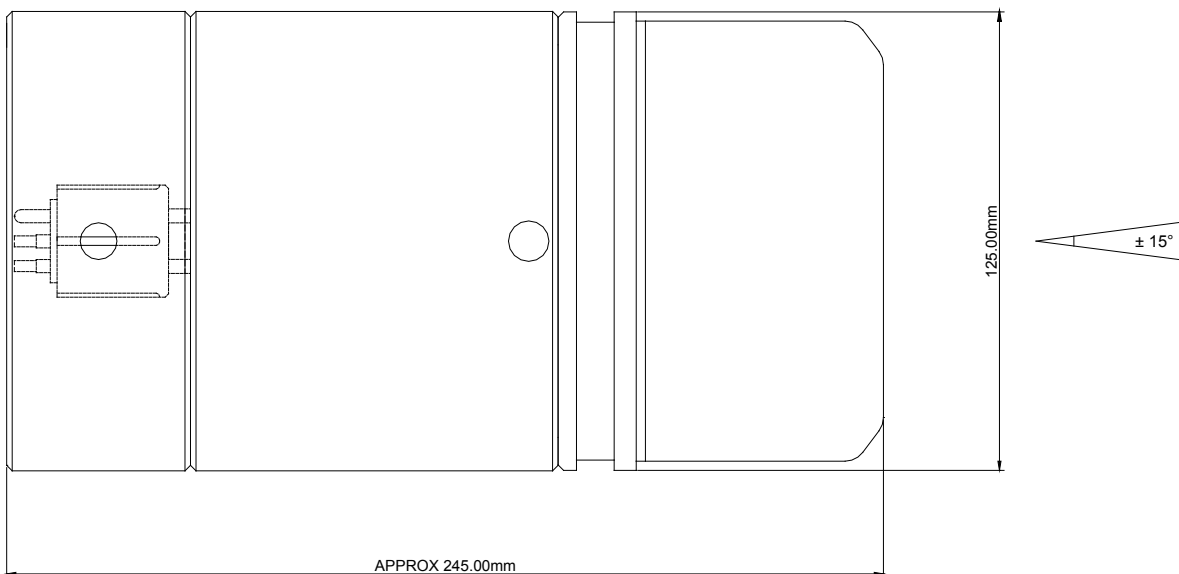

RM45

This is the same transducer element as used with the 935 beacon. When mounted in the RM45 housing it has a directional beam pattern of ± 45 degrees and a depth rating of 3000 metres. The same precautions about mounting apply to this model as the 7920A.

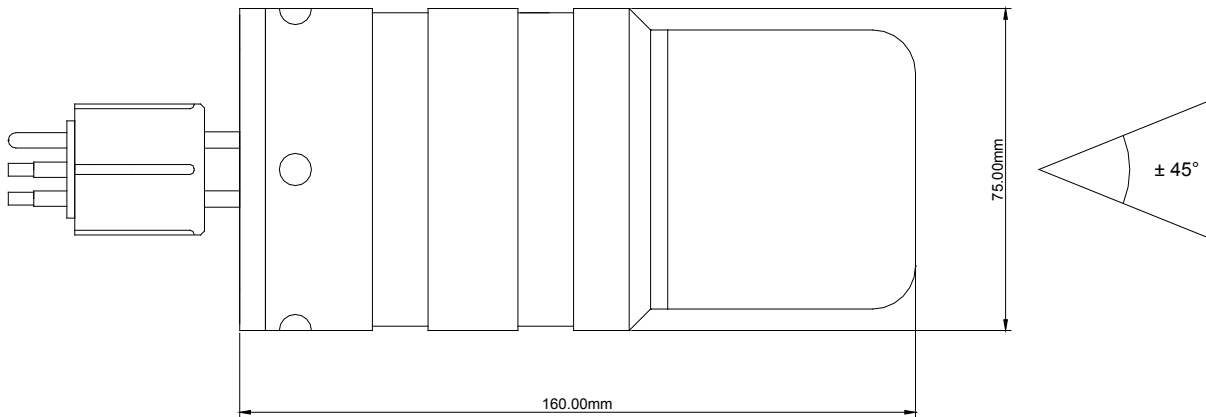

RM90

This transducer has a hemispherical beam pattern (omni directional) and has a depth rating of 1500 metres. Being non directional, the source level from the transducer is less than the other models listed above. We would not recommend this unit for long range work.

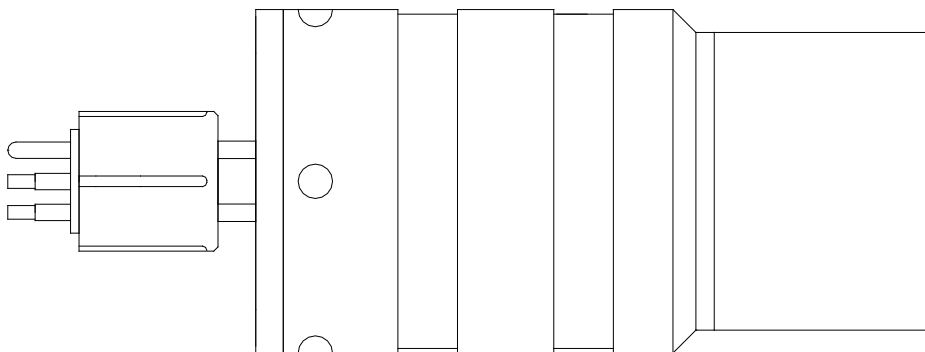

Note that the RM45 and the RM90 have been drawn without a protector ring for the electrical connector. This is usually supplied but can also be removed easily (4 screws). Electrical connectors should be clean and grease free. Rubber mating parts should be O-lubed (see elsewhere in the manual). Contact pins should be clean.

THIS PAGE IS INTENTIONALLY LEFT BLANK

Applied Acoustic Engineering is a leading company in the design and manufacture of a wide range of subsea navigation and positioning products, and marine seismic survey equipment.

The extensive product range includes the innovative USBL tracking system, Easytrak, a variety of positioning and release beacons and seismic devices for offshore geotechnical and seabed analysis known as sub-bottom profiling.

All products use acoustics, underwater sound waves, in location, positioning, navigation and data acquisition applications. system, Easytrak, a variety of positioning and release beacons and seismic devices for offshore geotechnical and seabed analysis known as sub-bottom profiling.



APPLIED ACOUSTICS
Underwater Technology

An AAE Technologies Group Company

Due to continual product improvement, specification information may be subject to change without notice.

© Applied Acoustic Engineering Limited