

# **SeaKing & SeaPrince Imaging Sonars**

## **Product Manual**

0374-SOM-00001, Issue: 08



© Tritech International Ltd

The copyright in this document is the property of Tritech International Ltd. The document is supplied by Tritech International Ltd on the understanding that it may not be copied, used, or disclosed to others except as authorised in writing by Tritech International Ltd.

Tritech International Ltd reserves the right to change, modify and update designs and specifications as part of their ongoing product development programme.

All product names are trademarks of their respective companies.

# Table of Contents

Warning Symbols .....	4
1. Introduction .....	5
2. Getting Started .....	6
3. Installation .....	9
3.1. General Overview .....	9
3.2. Seonet Pro Software .....	9
3.3. Installing the Sonar Head .....	10
3.3.1. SeaKing Communication Configuration .....	10
3.3.2. Subsea Sensor Electrical Installation .....	11
3.3.3. Ground Fault Monitoring Equipment .....	11
3.4. Waterblock Pin-out Diagram .....	12
4. Setup .....	13
4.1. Identifying the Model .....	13
4.2. Changing Configuration for Serial or ARCNET .....	14
4.3. Changing Configuration for Ethernet .....	15
5. Operation .....	17
5.1. Basic Principles .....	17
5.2. Operating the SeaKing & SeaPrince in Seonet Pro .....	18
5.2.1. Main Screen .....	18
5.2.2. Sonar Settings .....	19
5.2.3. Main Menu .....	20
5.2.4. Measurement Tool .....	24
5.2.5. Dynamic Range and Sonar Rx Indicator .....	25
5.2.6. Application Tools .....	26
6. Maintenance .....	32
6.1. After using the sonar .....	32
6.2. If storing the sonar for extended periods .....	32
6.3. SeaKing regular maintenance .....	32
6.3.1. Disassembly of the SeaKing unit .....	33
6.3.2. Reassembly of the SeaKing unit .....	35
6.4. Super SeaPrince regular maintenance .....	36
6.4.1. Disassembly of the Super SeaPrince unit .....	37
6.4.2. Reassembly of the Super SeaPrince unit .....	38
7. Troubleshooting .....	39
A. Help & Support .....	40
B. Specification .....	41
B.1. SeaKing .....	41
B.1.1. SeaKing Dimensions .....	41
B.1.2. SeaKing Physical Properties .....	42
B.1.3. SeaKing Acoustic Properties .....	42
B.1.4. SeaKing Display Characteristics .....	42
B.1.5. SeaKing Electrical and Communication .....	42
B.2. SeaPrince .....	43
B.2.1. SeaPrince Dimensions .....	43
B.2.2. SeaPrince Physical Properties .....	43
B.2.3. SeaPrince Acoustic Properties .....	44
B.2.4. SeaPrince Display Characteristics .....	44
B.2.5. SeaPrince Electrical and Communication .....	44
C. ARCNET Termination .....	45
D. CHIRP Signal Processing .....	46
E. SeaKing Sonar & Profiler Connector Options .....	48
F. Super SeaPrince External Reset .....	49
G. V6 COM PCB Reset .....	51
Glossary .....	53

## Warning Symbols

Throughout this manual the following symbols may be used where applicable to denote any particular hazards or areas which should be given special attention:



### Note

This symbol highlights anything which would be of particular interest to the reader or provides extra information outside of the current topic.



### Important

When this is shown there is potential to cause harm to the device due to static discharge. The components should not be handled without appropriate protection to prevent such a discharge occurring.



### Caution

This highlights areas where extra care is needed to ensure that certain delicate components are not damaged.



### Warning

**DANGER OF INJURY TO SELF OR OTHERS**

Where this symbol is present there is a serious risk of injury or loss of life. Care should be taken to follow the instructions correctly and also conduct a separate Risk Assessment prior to commencing work.

# 1. Introduction

The SeaKing and SeaPrince sonar "system" would consist of the sonar head, the *Tritech International Ltd* Seanet Pro control and display software and either a Surface Control Unit (SCU) or SeaHub. This manual deals with the sonar head and any specific aspects of Seanet Pro that are necessary to get a system working. For more details of Seanet Pro please refer to the Seanet Pro Software Manual and further details of the SeaHub or SCU can also be found in their respective manuals (all current manuals are available on [www.moog.com/tritech](http://www.moog.com/tritech)).

The Seanet Pro software is Windows based and provides control of the complete range of sonars that *Tritech International Ltd* produce. It is also possible to display multiple devices within Seanet Pro and as such two or more sonars can be networked together and displayed on one computer.

The SeaKing and SeaPrince sonar head is typically configured to communicate with the SCU or SeaHub using the ARCNET LAN telemetry protocol. This is the standard protocol that is used in all SeaKing devices and provides a high bandwidth at a default communications rate of 156kbit·s<sup>-1</sup>. It is also possible to reconfigure sensors to communicate at a lower baud rate or using serial protocols (such as RS232).

The DST SeaKing DFS & Super SeaPrince sonar heads have the following features:

Scan rate	The heads can achieve a very fast scan rate which gives faster target acquisition, and helps in obstacle avoidance.
Dual Frequency Operation (SeaKing only)	The SeaKing DFS can use up to two operating frequencies - one giving long range target acquisition characteristics and the other giving shorter range, higher definition, imaging capability. It is effectively two sonar heads in a single housing.
Protected transducer	The SeaKing has a semi-rigid rubber boot and the SeaPrince units have a rigid plastic boot, both are oil filled and offer protection of the transducer head. The unit has no rotating seals to be damaged or wear.
Electrical Connection	The SeaKing and SeaPrince heads use a <i>Tritech International Ltd</i> 6 pin underwater connector but can be fitted with an alternative connector on request.

## 2. Getting Started

This section will detail the basic steps required in order to connect up your Tritech Sonar for the first time to your surface controller (typically a Tritech SCU, PC or Laptop).

A standard Sonar system will comprise of the following elements:

- The Sonar unit - Super SeaKing or Super SeaPrince in this instance
- The Build Record Sheet - This contains detailed information on the configuration and pin outs specific to this unit
- Accessory kit - this will contain extra o-rings and screws. Depending on the Sonar unit it may also contain additional items
- Software and Manual CD - This holds a copy of all commercially released Tritech software as well as electronic copies of manuals for *Tritech International Ltd* products
- Cable whip - this is an optional item, but is usually supplied for units fitted with a standard *Tritech International Ltd* connector

Ensure that the surface controller has Seanet Pro installed onto it, using the supplied CD if necessary. The CD will contain a version of Seanet Pro that would have been appropriate at the time of the manufacture of the Sonar unit, but for the latest version it is recommended that the Tritech website be checked: [www.moog.com/tritech](http://www.moog.com/tritech)

Before attempting to connect up the Sonar with a test cable, check the communications setting of the Sonar either by referring to the label on the unit - or by checking the Build Record Sheet.

Once the setup of the Sonar is confirmed, use the cable whip (if supplied) to create a test cable. Depending on the setup of the Sonar, differing cable wiring may be required:

### ARCNET

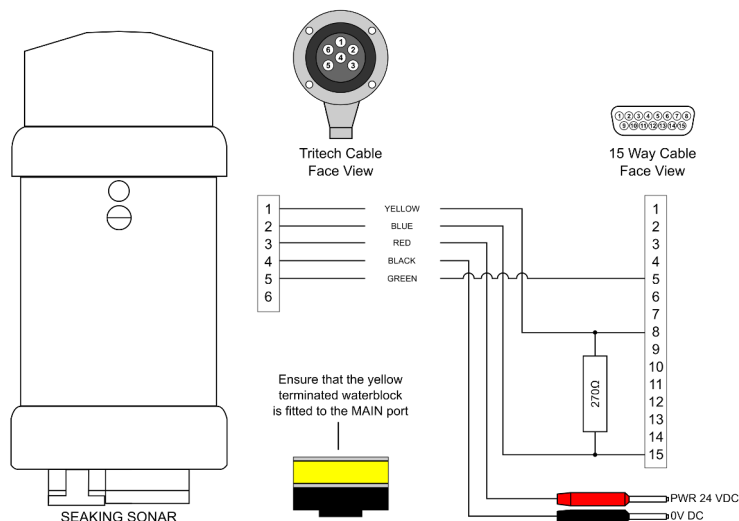

**RS232 or RS485**

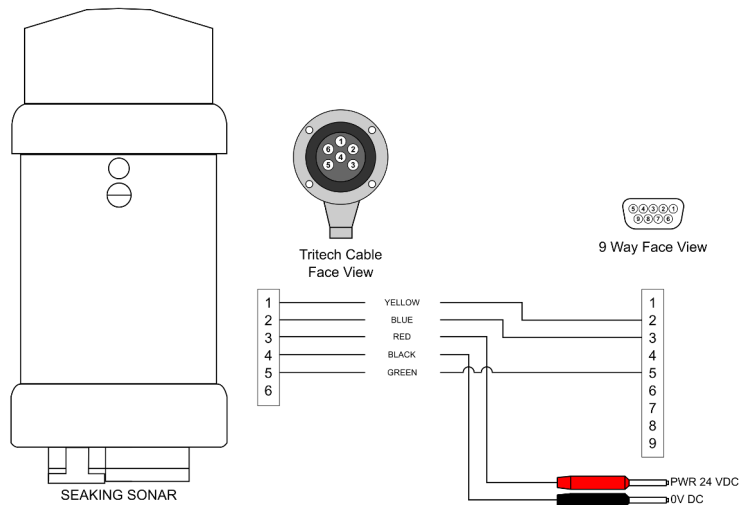

*Note: The wiring detailed above is for the SCU, SeaHub or MicronNav Hub. If using a third party RS485 adapter please check the pin outs required as the RS485 A and RS485 B pins may be configured differently.*

Using the test cable, connect the Sonar unit to your surface controller. Your surface controller can be a SCU, SeaHub, MicronNav Hub or a PC with a RS232 or RS485 port.

Run Seanet Pro and, if working over a serial interface, configure the serial ports using the **Utilities->Com Setup** drop down menu option.

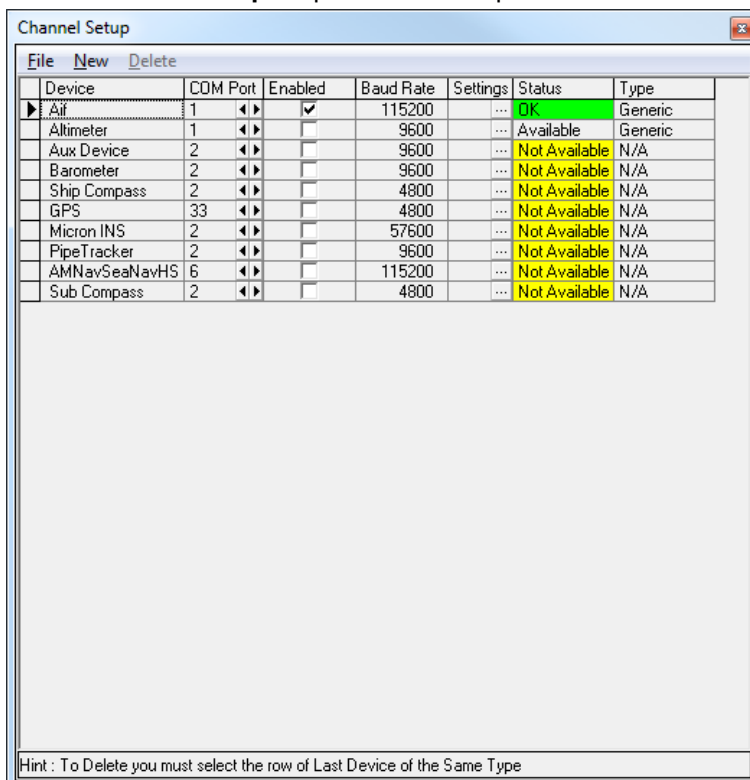

For the COM Port being used, ensure that an **AIF** device has been enabled.

Select the **Applications->Setup** drop down menu option.

The Node table should display the Node of the connected Sonar (normally Node 2, but the label on the unit should state what it has been set to) There may also be additional nodes, depending on how the system is all connected. A SCU or SeaHub will appear as Node 252, whereas a MicronNav Hub will appear as Node 90.

The Status of the Sonar Node should be OK. 

Status
OK

If the Status is UNKNOWN check the following: For RS232 wiring Pin 5 is properly connected For all wiring The main comms pins (1 and 2 on the waterblock) are wired correctly and have not been crossed

With the Status showing as OK, select the Applications->Single Sonar option

The data screen will report a centering message, as part of the Sonar boot up, then will start to scan.

It is recommended that the Super SeaKing Sonar is only run in air for short periods (1 hour maximum) as the unit will become hot to the touch without a body of water to help dissipate the heat.



## 3. Installation

### 3.1. General Overview

The SeaKing and SeaPrince heads are supplied with a waterblock fitted to the device and as standard a proprietary connector usually referred to as the "Tritech 6-Way Connector". Other connectors are available (see Appendix E, *SeaKing Sonar & Profiler Connector Options*) and various lengths of test cable can be supplied with the connector. For more details contact *Tritech International Ltd.*

The waterblock is fastened to the body tube of the head, and provides a 4000m rated pressure bulkhead. This will protect the electronics from water ingress in case the connector is damaged or not fitted correctly. The connector may be disconnected from the heads by unscrewing the four securing screws.



#### Note

It is not necessary to remove the water block when removing the connector or taking the head apart. Whilst the connector is removed from the head, the blanking plugs supplied should be fitted to prevent the ingress of dirt or moisture.

### 3.2. Seanet Pro Software



#### Warning

SeaPrince Sonars with serial numbers 318289 and above incorporate the Mod B improvements and updated firmware. If being used with Seanet Pro version V2.24 dated prior to Feb 2020 do not "Update" the firmware as this will install a previous version and may render the unit inoperable.

It is recommend that the Seanet Pro software be updated to V2.24 dated 03/02/2020 available from the Tritech website and contained on Rev 3 of the Software and Manuals USB (0084-SOF-00002).

Should the previous version of firmware be loaded onto the SeaPrince Sonar connection of the unit to an installation of Seanet Pro V2.24 (03/02/2020) will allow the firmware to be updated to the correct revision.

The Seanet Pro Windows software will be provided either on an Installation CD-ROM (for SeaHub interface to user computer) or pre-installed on the Seanet SCU.

For the CD-ROM Installation, if Setup does not auto-run on disc insertion, run the SETUP.EXE file from the disc to start the installation.



#### Note

A DST SeaKing or SeaPrince sonar head will not work with the SONV3 application or run on a SCUv3

### 3.3. Installing the Sonar Head



#### Caution

Although the sonar heads are rugged, they should be handled with care, particularly the connector and transducer.

The heads should be secured by clamping on the cylindrical body section such that the transducer is unimpeded and not shielded. A guard can be fitted over the head to protect from impact damage but this must not overlap the transducer area or it may have an effect on the sonar image.



#### Caution

It is important that no clamping force is applied to the boot.

The clamp should be applied centrally to the aluminium body tube and should not be over-tightened. Any metallic clamps should be electrically insulated from the sonar body by means of rubber or plastic strips or mount brackets of at least 3mm thickness and extending at least 3mm beyond the clamp boundary to reduce any galvanic corrosion effect. Non-metallic clamps are preferable: if metallic clamps are used they should be painted or lacquered with at least two or three coatings.



#### Caution

Avoid any metal alloys containing copper such as brass or bronze.

Care should be taken to mount sonar heads to ensure that they are mounted as close to the true vertical as possible in relation to the trim position of the vehicle. The front filling plug and red LED should be aligned with the natural direction of travel of the vehicle. Errors in the head alignment can give rise to unreliable results.

#### 3.3.1. SeaKing Communication Configuration



#### Caution

The power should be turned off before making a connection between the sonar head and surface controller (SCU or SeaHub).

The Sonar head may form part of an ARCNET multi-drop, network of sensors that are normally interfaced to the Surface Unit through the internal AIF interface PCB (installed in the SCU) or external SeaHub serial interface module.

Normal communications with the Sonar head is via a customised version of the ARCNET network system and requires a good quality balanced twisted pair cable. It is possible to interface the ARCNET to wide band multiplexer systems - contact *Tritech International Ltd* for details.



#### Note

For an ARCNET connection termination resistors need to be fitted at each end of the umbilical. Refer to Appendix C, *ARCNET Termination*

The Seonet SCU and SeaKing heads cannot be used with RS232 or RS485 AIF Cards as used in earlier WINSON based SCU-3 systems. They must be used with SeaKing AIF

ARCNET cards (AIFV3/V4). Conversely, Series 2 Sonar, Profiler and other heads cannot be directly used with SeaKing and Seanel systems. Note that the SCUv5 units do not have a dedicated AIF ARCNET card but instead process the ARCNET data through the SCU main board. In terms of software and hardware interface though this is exactly the same as using an AIF card as in the older SCUv4 units.

An optional RS232 interface can be provided to allow telemetry connection through a fibre optic system capable of 115kbps transmission. The RS232 interface is available in the guise of an RS232 to ARCNET converter PCB that is installed in a dry pod on the vehicle. Alternatively, an intelligent 4000m pressure rated Junction Box will provide the RS232 interface to the network of SeaKing ARCNET devices.



### Note

SeaKing units with a V6 COM PCB are capable of using a single-head RS232 or RS485 interface. Older units with a COMv5 PCB, or older, will only be able to communicate via RS232.

Super SeaPrince units are capable of communicating on all three protocol options as standard

Refer to the Seanel Pro and Seanel SCU manuals for more information on serial RS232/RS485 configuration and baud setup.

## 3.3.2. Subsea Sensor Electrical Installation

If using a rectified transformer PSU, the output of the PSU must have a filter capacitor of not less than 470 $\mu$ F, for each head being powered. If an unregulated PSU is used, then make sure that the voltage value measured at the head is in the range 20-36v DC, in power on/off and running conditions. If powering the head(s) down a long lead or umbilical, the maximum recommended loop resistance of the power line must not exceed 10 $\Omega$  for one head, 5 $\Omega$  for two heads, and 3 $\Omega$  for three heads. If the supplied voltage is less than 20V DC (or 12V for Super SeaPrince DST) the sonar head may not operate correctly.



### Caution

Never try to make SeaKing or SeaPrince sonar work down a long cable by increasing the PSU output voltage above 36V DC (or 56V DC for the high voltage Super SeaPrince).

## 3.3.3. Ground Fault Monitoring Equipment

The power supply within SeaKing subsea devices includes an electrically isolated DC-DC converter front-end, There is a small capacitive connection to the sonar chassis which should not noticeably affect any impressed current ground fault indicator (GFI) equipment.

### 3.4. Waterblock Pin-out Diagram

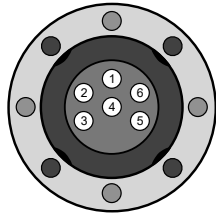

**Figure 3.1. Tritech Waterblock**

Pin	MAIN port	AUX port	Cable colour
1	RS232 TX ARCNET A RS485 A	RS232 RX ARCNET A RS485 A	Yellow
2	RS232 Rx ARCNET B RS485 B	RS232 TX ARCNET B RS485 B	Blue
3	+DC Power		Red
4	-DC Power		Black
5	RS232 Ground		Green
6	Earth/cable shield		cable screen

## 4. Setup

The SeaKing and SeaPrince sonar heads, when newly purchased, will be setup as requested. However, should the setup of the units need to be changed the following instructions can be used to reconfigure the units as desired.

### 4.1. Identifying the Model



Before proceeding with any reconfiguration, it is vital to know what model of SeaKing Sonar you are operating with.

#### SeaKing V5 or older

SeaKing Sonars that are V5 or older models need to be opened in order to change their configuration. Additionally these Sonars may, or may not have a V6 COMS PCB installed and so will use physical jumpers to set up the communications options. Please see *0374-SOM-00003* for jumper configurations as well as V6 COMS PCB DIP switch settings for these units.

#### SeaKing V6

A V6 SeaKing Sonar will typically have the part number S06332A, printed on the main product label. It should also have the V6 Comms box checked on the label.

Tritech .co.uk		SeaKing sonar	
Model:	Super SeaKing DST Sonar		
Depth:	4000m		
Revision:	V6		
Channel 1:	LF	2:	HF
Supply voltage:	Other		
20-36V	<input type="checkbox"/>	20-72V	<input checked="" type="checkbox"/>
Communications:			
Main		Aux	
RS232	<input type="checkbox"/>	RS232	<input checked="" type="checkbox"/>
RS485	<input type="checkbox"/>	RS485	<input type="checkbox"/>
Arcnet	<input checked="" type="checkbox"/>	Arcnet	<input type="checkbox"/>
Node		2	
COM V6		<input checked="" type="checkbox"/>	
S/N:	06332A.123456		
		  	

#### SeaKing V7

A V7 SeaKing Sonar has a different style of product label from that of the V6.

## 4.2. Changing Configuration for Serial or ARCNET



### Note

These instructions are intended for units that support software selectable communications. If you are unsure if your Sonar supports this function, please check Section 4.1, "Identifying the Model" or contact *Tritech International Ltd* for assistance.

To change the configuration of the SeaKing or SeaPrince Sonar, the following steps should be undertaken:

1. Place the Sonar on a short test cable and connect to your controlling computer (either directly or via SeaHub / MicronNav Hub / SCU)
2. Using the **Applications - Setup** ensure that you can see the Node of the Sonar - typically Node 2
3. In the **Action** column, click on the down arrow and select **Setup**
4. Click **Ok** on the pop up warning and the Sonar Setup page should now appear
5. Select the desired communication options from the **MAIN** and **AUX** drop down lists
6. If required, click on the **Baud Rates** button to open and change the baud rates used by the ARCNET and serial outputs of the Sonar
7. Once all changes have been made, click **Ok** to apply the changes
8. The Sonar will now be reprogrammed and will disappear from the Node Table
9. Wait for the Green LED on the Sonar to start flashing, then power it down and disconnect the test cable
10. Re attach the Sonar to the computer using a new test cable suitable for the new communications method
11. Power the Sonar back on and, after a brief delay, the Sonar Node number should reappear

For Sonars using Ethernet communications, changing the IP Address of the Sonar will not require a change in test cable - but it will need the computer and Sonar to be on the same domain in order to establish communications.

### 4.3. Changing Configuration for Ethernet



#### Note

Currently only the SeaKing V7 supports Ethernet communications, with the label showing this option instead of ARCNET.

To change the setup of an Ethernet enabled sonar the following steps should be undertaken:

1. Place the unit on a short test lead directly into the Ethernet port of the controlling computer
2. Change the IP address of the controlling computer to the same domain as the Sonar - typically in the 192.168.2.xxx range
3. Using the **Applications - Setup** ensure that you can see the Node of the Sonar - typically Node 2
4. In the **Action** column, click on the down arrow and select **Setup**
5. Click **Ok** on the pop up warning and the Sonar Setup page should now appear
6. In the Sonar Setup page, click on the **COMV7** tab to show the IP settings of the Sonar
7. Enter the new IP Address for the Sonar as required
8. Once all changes have been made, click **Ok** to apply the changes
9. The Sonar will now be reprogrammed and will disappear from the Node Table
10. If you have changed one of the first three numbers in the IP address, the controlling computer will need to change its IP domain to match once again
11. If the last number of the IP Address has been updated, the Sonar should be detected after a short delay

**Note**

The SeaKing Sonar uses a set Subnet Mask of 255.255.255.0.



## 5. Operation

### 5.1. Basic Principles

On completion of installation of the sonar on a vehicle, it can be tested in air by powering up the system and observing that the red LED illuminates as the head scans through the ahead direction.

As with any active sonar, the SeaKing and SeaPrince sonar heads only show echoes of objects that reflect sound back to the sonar transducer, such that hard shiny surfaces are sometimes only seen when they are at right angles to the sonar beam. Rough seabed textures can blot out smaller targets completely. The plan view also does not show how high an object is, unless a shadow is cast, in which case the length of the shadow is related to the height of the object, its range, and the height of the sonar head.

The SeaKing DFS Sonar is normally supplied with two operating frequencies, typically 325kHz and 675kHz. SeaPrince DST heads only have a single operating frequency, typically 675kHz. DST heads use chirped frequencies centred close to these values. The lower 325 kHz frequency is capable of detecting large targets at ranges in excess of 200 metres. The higher frequency has a narrow horizontal beam and wider vertical beam, for higher detail of closer targets. Switching between the two operating frequencies is performed by using RAT button F5 (or the RAT mimic in Seanet Pro). The current operating frequency is indicated in the F5 panel above the sonar display. If operating on range scales greater than 100 metres, use the lower frequency for maximum range performance.

Interpretation of sonar data develops with experience. Sonar reflections of isolated small objects give no indication of shape or attitude. Man-made structures, such as platforms or rock walls tend to have regular patterns that are easier to identify. Using sonar is rather like looking at a world made of shiny black plastic, in the dark, with only a narrow torch beam for illumination. Remember that when close to large objects, or in a depression in the seabed, that the viewing range may be severely limited. Very strong reflectors may give multiple echoes along a bearing line, and are identified by being equally spaced in range. If they persist, reduce the gain.

When searching for objects, hold the vehicle heading as steady as possible to stop the image blurring. Sit on the seabed if necessary.

Depending on water depth and vehicle depth, there may be ring like echoes. These can be caused by surface or seabed direct reflections and may be difficult to avoid.

Experience with the sonar will enable the operator to be able to quickly and effectively set the "Gain" and "Threshold" controls to give as even a background as possible, without swamping the display, and maximise the performance capabilities of the head. The threshold control is used to mask out any unwanted clutter caused by the weaker returns.

There are 4 range resolutions available, selected from the Main Menu. As you increase the resolution from Low to Medium to High to Ultimate, the sonar display will show better resolution, but at a lower scan speed. Use of a lower resolution will give faster scan speed, but with coarser detail. When searching for smaller targets close by, select a higher resolution mode at the higher frequency. When searching for large targets at long range use a lower resolution on a lower frequency

## 5.2. Operating the SeaKing & SeaPrince in Seanet Pro



### Note

These instructions detail the use of the Seaking and the Seaprince imaging sonars with the Seanet Pro software.

Please refer to the relevant software and quick start guides for the use of the sonars with the Genesis software suite.

### 5.2.1. Main Screen

The Seanet Pro application can be run from the Programs group in the Windows Start menu or from the desktop by double clicking on the shortcut icon.

The Seanet Pro screen display shown below is a Gemini, SeaKing & Bathymetric application, although the view will vary depending on the applications chosen, each application will have a similar layout.

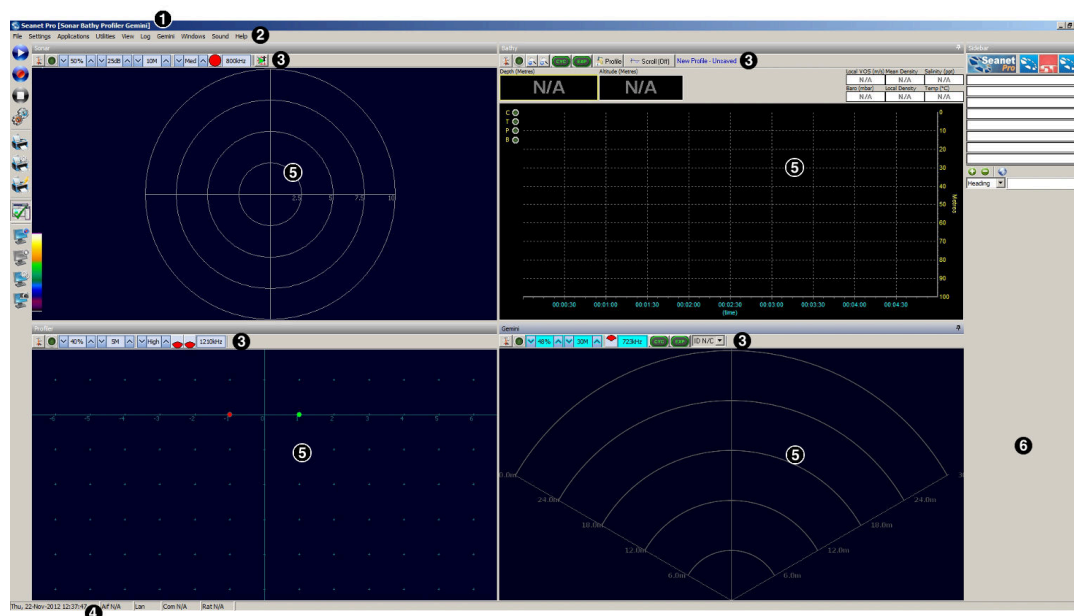

**Figure 5.1.**

The main areas of the display are:

1. **Display Header** This part of the screen is used for system/software identification.
2. **Menu Bar** This is where system set-up functions can be accessed. Printing, Application selection, Colour Scheme setup and Logging are some of the features that can be accessed in this screen area.
3. **Settings Bar** This is where the Sensor can be controlled and configured. The Settings bar is on top of every display window for each device that is connected to the system. It includes a Tools Setup button, Led indicator (Pause/Go) and RAT dials and buttons
4. **Status Bar** This part of the screen is used to display system status information, typically the AIF card interface status, Logging status/progress and Job specific information.
5. **Sensor Display Area** This part of the screen is where the main Sensor data is displayed. Other pertinent data such as Range Scale, Cursor and status messages

pertaining to the Sensor may also be displayed within this area - Refer to the manual section provided with each Sensor for further details of its display area.

6. **Sidebar** This is where Serial input data and user text can be displayed. This bar can be placed on the Left or Right hand side with RHS the default setting. The operator can choose to have this bar visible or not and it can also be folded away.

### 5.2.2. Sonar Settings

These controls are displayed on the Sonar Settings bar. When the RAT is used or screen cursor is moved over the Sonar Settings bar, a pop-up control panel will appear which will display the remaining controls. These mimic the positions of the rotary controls (C1 to C5) and function buttons (F1 to F7) on the RAT. Adjustments may be made using the RAT or the on screen controls using the pointer device.

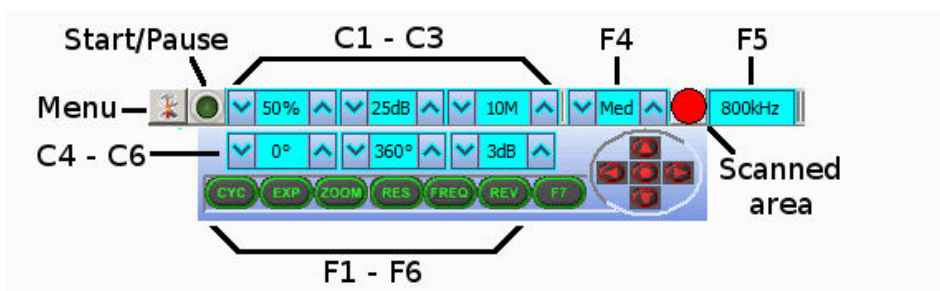

Figure 5.2.



#### Note

F1, F2 are not applicable in single window applications, F7 is not used.

Sonar Gain (C1)	This sets the sonar receive gain as required – typically this is around 50% but is varied according to water and target conditions and user preference.
Contrast (C2)	This sets the display contrast between hard and soft targets. Usually set to user preference, it can help find small features in generally featureless situation or exclude clutter from a heavily featured seabed.
Range (C3)	This sets the maximum range the sonar will scan. Long ranges are scanned more slowly than short ranges due to the limit imposed by the velocity of sound in water.
Sector Scan Direction (C4)	This is used to set the centre of the scanned sector particularly useful when using a narrow sector width to concentrate on a particular feature. A well positioned, narrow sector will allow faster scan updates than a wide sector.
Sector Scan Width (C5)	This sets the width of the scanned sector. Typically this will be adjusted according to the required seabed coverage.
Display Sensitivity (C6)	This sets the display sensitivity threshold. A low setting will effectively remove very low level returns from being displayed which may include (soft) seabed backscatter whereas a higher setting will start to remove higher amplitude echoes which may include objects of interest.

It is normal to keep this at a low setting of no more than 5dB to remove low level 'noise'.

CYC (F1) - Cycle Window	This can be used when one of the display windows is maximised using the Expand (F2) button and will cycle between the Sonar display windows. Also use the F1 button to switch focus between the display windows. The optional RAT controller will switch its control to the display that has the focus. Note: clicking on a display with the mouse pointer will also switch focus to that display.
EXP (F2) - Expand Window	This will maximise the current display window that is in focus. Either click on a display window to switch focus to it before expanding, or press the Cycle (F1) button to switch focus to a display window.
ZOOM (F3)	This will toggle the Acoustic Zoom window on/off. This draws a zoom box on the display positioned by the cursor. This control is also toggled via Application Tools - Acoustic Zoom. The Zoom window size and magnification can then be adjusted in 'Zoom Setup' in the Application Tools.
RES (F4) – Sonar Resolution	Resolution toggles through preset step sizes for the sonar scanning. Available step sizes is dependant on the sonar being used. Smaller angles give a higher resolution picture but slower scan speeds. Usually a Lo or Med resolution is used for tracking moving targets and Hi or Ult for detailed examination of static targets.
FREQ (F5) - Sonar Frequency	This toggles between the channels available on the sonar. For a single frequency sonar unit this control will be inactive and will lock to indicate the operating frequency of the sonar.
REV (F6) - Reverse Scan Direction	This allows the operator to instantly reverse the scan direction without waiting to reach the end of the scanned sector.
Sector Quick Select	This group of 5 buttons in the bottom right of the control allows the user to make a quick selection of a full 360° scan or 180° forward, back, left or right. The display view is changed automatically and the appropriate sector width and direction set.

### 5.2.3. Main Menu



**Figure 5.3.**

1. Print Output screenshot to printer.

2. `Screen Capture` Screen to AVI or save screen to Bitmap/Tiff.
3. `Exit` Used to exit program.

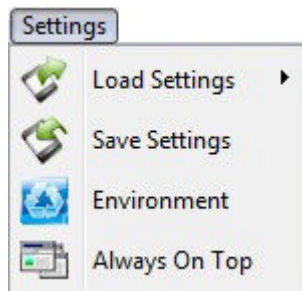

**Figure 5.4.**

1. `Load/Save Settings` Save and Load the current display and device settings (up to 8 can be saved).
2. `Environment` Used to enter environmental parameters such as system Velocity Of Sound.
3. `Always On Top` Main Screen is Always on Top of Windows desktop.

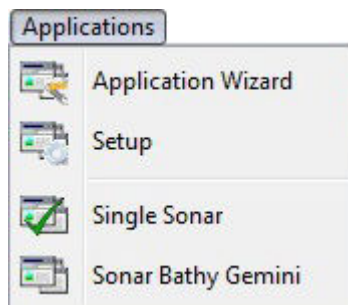

**Figure 5.5.**

This Menu Item will only be present in Seanet Pro and not from running Seanet Setup from the desktop icon. Application examples include `Single Sonar`, `Sonar Profiler` and `Sonar Bathy Profiler`. There is also an `Application Wizard` available at the top of the list which can be used to create user applications for required device combinations.

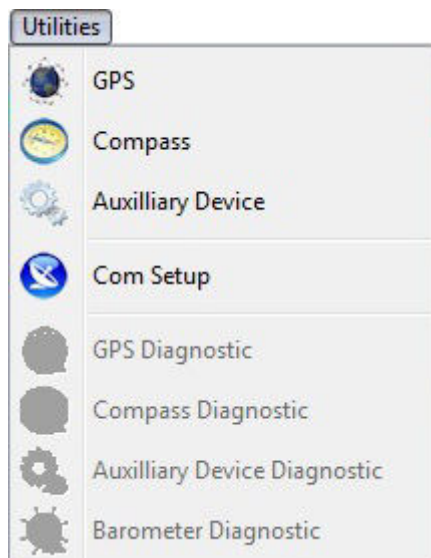

**Figure 5.6.**

1. GPS Pop-up Form to display GPS data received through a COM port.
2. Compass Pop-up Form to display Compass data received through a COM port.
3. Auxiliary Device Pop-up Form to display Aux Device data (i.e. Digiquartz Pressure Sensor or PA/NMEA Altimeter data) received through a COM port.
4. Com Setup Configure and Enable COM ports for various serial inputs/devices including GPS, Pipetracker, Barometer and Compass.
5. GPS Diagnostic Terminal window for viewing received serial data.
6. Compass Diagnostic Terminal window for viewing received serial data.
7. Auxiliary Device Diagnostic Terminal window for viewing received serial data.
8. Barometer Diagnostic Terminal window for viewing received serial data.

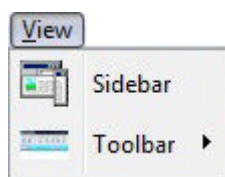

**Figure 5.7.**

1. **Sidebar** Enable/Disable the Sidebar. Note: In certain applications, i.e. 'Sonar Video', the Sidebar will be opened and docked to the blank ¼ window panel filler.
2. **Toolbars** There are several toolbars containing shortcut buttons which can be displayed in the Menu Bar area or docked to the sides of the Display Area. For details see the "Toolbar Shortcut Buttons" section.

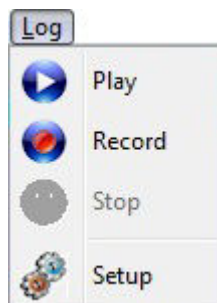

**Figure 5.8.**

1. **Play** Use to play back recorded log data (follow the on screen display).
2. **Record** Use to record Sonar data (follow the on screen display).
3. **Stop** Stop recording and/or Auto Logging.
4. **Setup** Select file options for recording log files (Follow the on screen display).

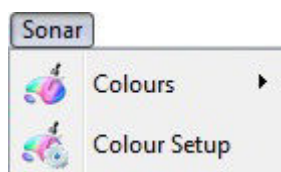
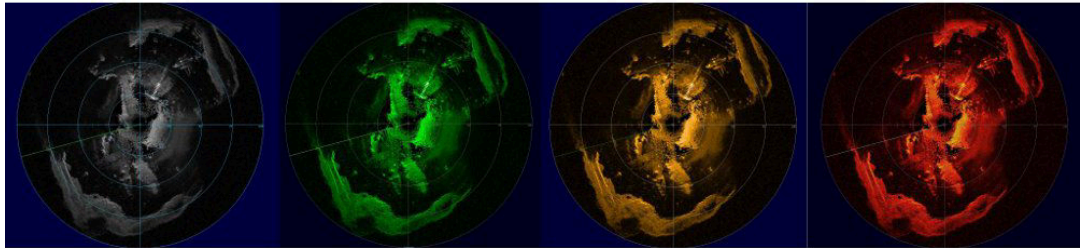

**Figure 5.9.**

Sonar (this will be renamed for other devices, e.g., Sidescan, Profiler, Bathy)

1. **Colours** Use to select a saved colour scheme.
2. **Colour Setup** Use to configure the existing colour scheme or create a new colour scheme.

Some examples of colour schemes that are available by default:



**Figure 5.10.**



**Figure 5.11.**

Windows (only functional in multi-Sensor Applications)

1. **Cycle F1** Cycle to the next Display Window (can also be done using the F1 key).
2. **Zoom F2** Enlarge the current Display Window to fill the window, click again to display all the Display Windows (can also be done with the F2 key).
3. **Sonar** Switch focus to Sonar Display window.
4. **Sidebar** Will be replaced with name of another Sensor in a Multi-Sensor Application.

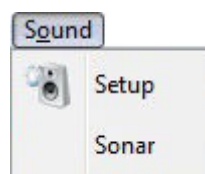

**Figure 5.12.**

The **Sound** menu enables an acoustic representation of the visuals presented on the Main Screen of the Seanet Pro application. Clicking on **Setup** allows configuration of how this sound is represented.



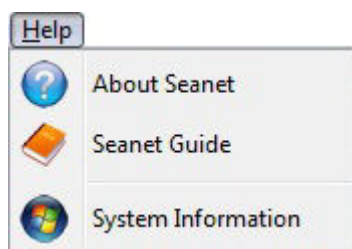

**Figure 5.13.**

1. `About Seanet` Gives details of program and version number.
2. `Seanet Guide` Seanet Help file.
3. `System Information` Gives information of computer resources in use.

### 5.2.4. Measurement Tool

By left button clicking and dragging on the Sonar display window (or Acoustic Zoom window) an elastic band is laid for range and position measuring of targets.

$D_x, D_y$  = Cartesian co-ordinates of current pointer position relative to Sonar.

$R_{ng}, B_{rg}$  = Polar position of pointer relative to where elastic band was laid.



#### **Note**

The range units used are those selected in the Setup menu.



## 5.2.5. Dynamic Range and Sonar Rx Indicator



The dynamic range bar is the A/D sample window (with 64-colour mapping) for the Sonar receive signal (which extends from 0 to 80dB).

To the right of the dynamic range bar is the Sonar receive signal strength indicator (Yellow = Average amplitude over scan-line, Red = Maximum amplitude echo for scan-line).

Normally the sampling window should not need to be adjusted from its default position (as shown on the left). However, if used properly, adjusting the sample window can produce better quality imaging.

The dynamic range bar can be adjusted to change Sonar display contrast and sensitivity. Adjustment is made using the left and right mouse buttons.

Contrast adjustment

Right-click on the bar and whilst holding down the right button, move the mouse up/down to increase/decrease the size of the bar. The sampling window can be any size between a range of 9 - 25dB. Decrease the size of the sampling window to increase the sonar display contrast. Ideally the control should be set somewhere in the centre of the allowed range (16 - 18 dB) to give the best results under most conditions. Select a high value to reduce the contrast of the sonar display.

Sensitivity adjustment

Left-click on the bar and whilst holding down the left button, move the mouse up/down to decrease/increase the Sensitivity of the Sonar receiver. Decreasing the Sensitivity will produce a more saturated display with greater weak-return content. Increasing the Sensitivity will omit background noise and low level returns seen at the receiver

**Figure 5.14.**

The sonar receiver will accept a return signal in the region of 0 - 80dB. The dynamic range controls are used to adjust the position of a sampling window within the 0-80dB dynamic range band of the receive signal. An idealised representation of the sample window is shown:

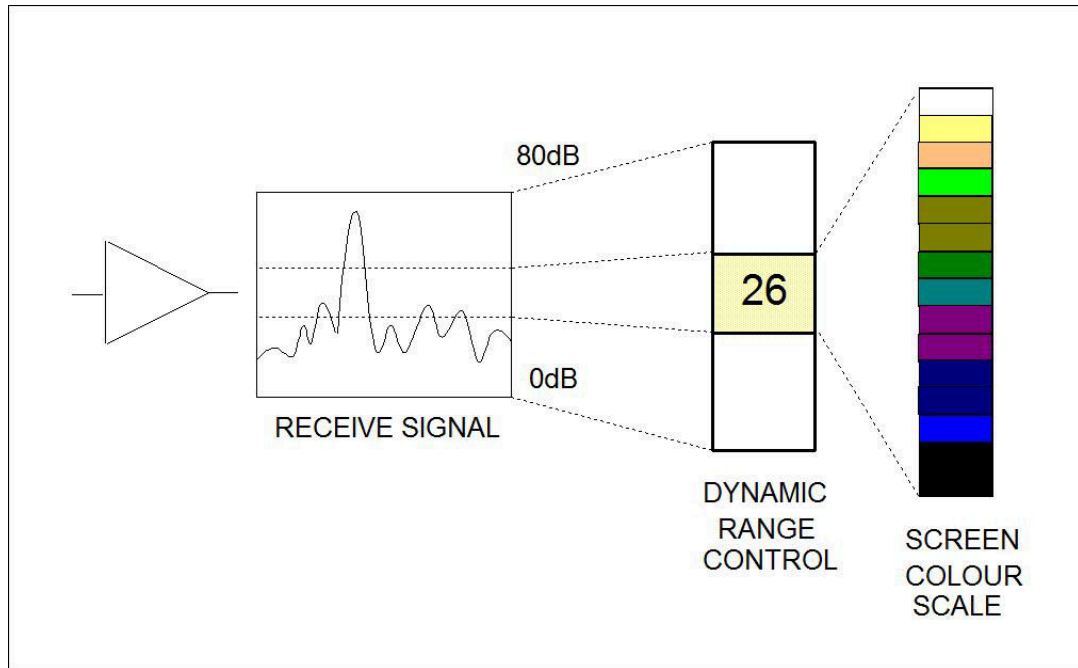

Figure 5.15.

## 5.2.6. Application Tools

### Markers

Markers A-B		
	16.27	353.1°
	18.58	7.7°
Delta	5.00	63.1°

Figure 5.16.

Adds A and B markers onto the sonar display, the range and bearing to each marker & separation and relative bearing are shown.

Click on the symbol to deploy on the Marker panel and that marker symbol will be dropped at the Origin (0, 0) on the Sonar display. Then, pick up the Marker using the left mouse button and drag it to the position required.

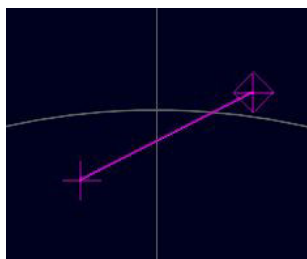
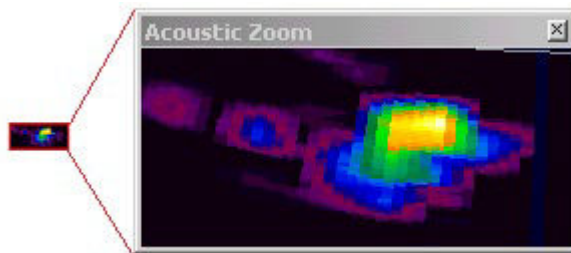

Figure 5.17.

When both markers are dropped on the display, a line will be drawn which connects them. The 'Delta' Range and Bearing at the bottom of the panel indicates separation and angle between both Markers.

There are 4 sets of Markers that can be implemented; A-B, C-D, E-F, G-H. The operation of each set is the same as A-B described above.

**Acoustic Zoom**



**Figure 5.18.**

True Sonar Zoom mode draws a zoom box on the display positioned by cursor. The sonar will take more samples in the area of the zoom box for target magnification.

Zoom Setup sets the size and magnification factor of zoom box.

The Size shows the screen zoomed area (red outline) as a percentage of the Acoustic Zoom display window.

The Factor shows the number of zoomed range bins for each normal range bin. For instance, a Factor of 4 will take four times the number of samples within the zoomed area than will be taken outside the zoomed area.

**Position**

Used to move and size the Sonar PPI display in its display window.

Centre X/Y - Adjust X & Y centre position of the display, Radius - Size the display.

**Display**

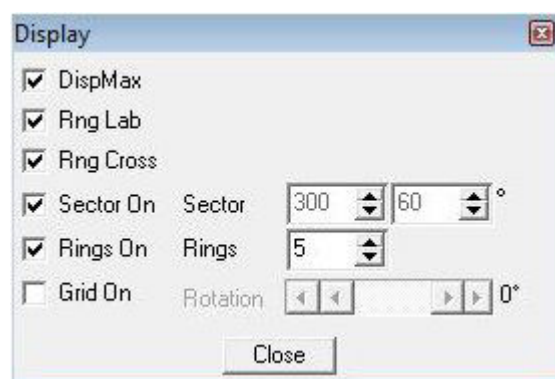

**Figure 5.19.**

Sets up sonar display options.

DispMax – Tick to expand sonar display vertically to fit window. If un-ticked will expand horizontally.

RngLab – Switch the Range Labels On / Off.

Rng Cross, Rings On, Rings, Grid On - Display Grid line options.

Sector On, Sector – Display a Sector overlay with left and right angular limit adjustment (in degrees).

Rotation – Rotational offset to correct Sonar heading – (Disabled for Gemini Sonar).

**Installation**

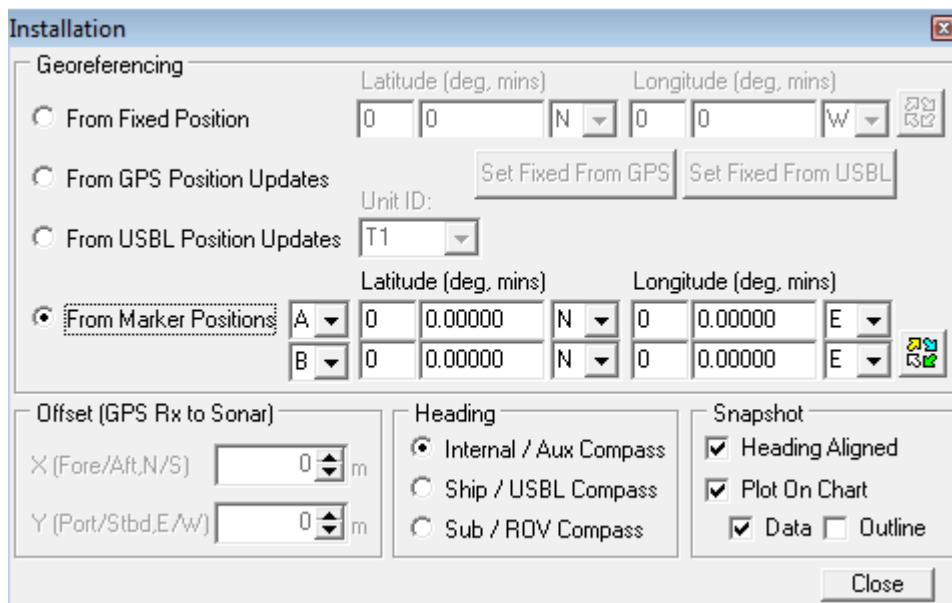

**Figure 5.20.**

This configures the location of the Sonar in the real world and enables the Geo-referencing of sonar targets on the sonar display.

- From Fixed Position**      If there is no GPS input, select this option and input the Sonar position in Latitude and Longitude co-ordinates (DegMin or DegMinSec format). A Heading input will also be applied, else a zero degree heading is applied. If present it is also possible to set the fixed position from the USBL or GPS input so that they can be disconnected and the position will remain persistent – simply click the appropriate button “Set Fixed from GPS” or “Set Fixed From USBL”
- From GPS Position Updates**      If a GPS input is active, select this option. A Heading input will also need to be active for the Geo-referencing to be functional.
- From USBL Position Updates**      If a USBL input is active, select this option. A Heading input will also need to be active for the Geo-referencing to be functional.
- From Marker Positions**      This function requires an application with Sonar and Nav displays loaded (e.g., by selecting Settings→Applications→Sonar Nav). The chart of the Nav display is used to obtain the Marker position references to be used in this function. If a Nav chart is not used then the Marker positions must be manually entered in the Sonar display.
- Offset (GPS RX to Sonar)**      X and Y position offsets should be entered if there is any offset between GPS receiver and Sonar (e.g. for a ship hull mounted system). Or, for an ROV mounted sonar, if the GPS position

updates are the position of a sub/vehicle then this offset may apply for the separation between a beacon/transponder and the sonar.

Heading

Use this option to select the source of the heading data. If using a sonar which contains an internal heading and compass device or if the compass is connected to the Aux port of the sonar select Internal/Aux Compass. If the compass device has been connected through a COM port on the SCU or PC, or if a USBL system is in use then select Ship/USBL Compass. If the sonar is mounted to an ROV and both the ROV and support vessel have a compass it is possible to switch to the ROV compass by selecting Sub/ROV Compass.

Once position and heading data are present, the Cursor display will be extended to provide position co-ordinates when the mouse cursor is moved around the sonar plotter.



**Note**

There must be active sonar data, as well as position and heading data, for the position co-ordinates to be reported.

**Setup**

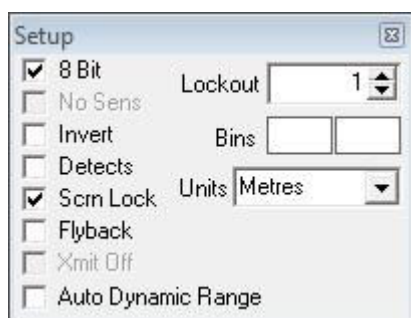
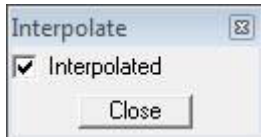

**Figure 5.21.**

- 8 Bit                                      Usually checked. Selects the intensity sampling of sonar data (4-bit or 8-bit).
- No Sens                                    Must be off (grayed out as shown) for normal use to synchronise angular head alignment.
- Invert                                       Swaps the display from left to right. Enable if mounted with Sonar boot down.
- Detects                                     Paint the leading edge of strong targets on the screen (only applicable to certain models of sonar).
- Scrn Lock                                    Locks the number of range bins sampled to the screen resolution.
- Flyback                                      Sets the sector scan to flyback instead of scan back. Normally off.
- Xmit Off                                     This option is not available under normal operation. It is a diagnostics level tool that will switch off the Sonar transmitter for test purposes.
- Auto Dynamic Range                      This will auto adjust the Display Contrast and Sensitivity whilst the Sonar is scanning. Auto adjustment occurs at the end of each full sonar scan.

Lockout	Sets a minimum range for the Detects (always in metres).
Bins	This is the number of samples taken over the current scan-line.
Units	Select the display range units. Options are Metres, Feet, Fathoms & Yards.

**Interpolate**



**Figure 5.22.**

Applies interpolation between adjacent samples on the Sonar display. Blends out contrast and ‘blockiness’ on lower ranges and resolutions.

**Auxiliary Compass**



**Figure 5.23.**

Sonar heads fitted with an Auxiliary (AUX) port can connect a serial RS232 or RS485 compass. The compass string (such as from a TCM-2 or CDL Gyro) includes Heading, Pitch and Roll data which is then displayed in the Aux Compass pop-up form. Ensure that the correct compass is selected in the Installation dialog.

**Overlay**

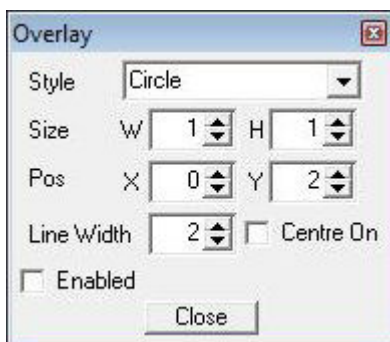

**Figure 5.24.**

When enabled, this option can be used to place and size an overlay shape or outline onto the Sonar display canvas.

Style	Select the type of shape from; Circle, Rectangle. Triangle.
Size	Set the Width and Height of the shape.
Pos	Move the Shape with X, Y position offset from display origin.
Line Width	Line width.
Centre On	Enable centre marker (+) for the shape.

## 6. Maintenance

### 6.1. After using the sonar

Make sure that after using the sonar head that it is washed down with fresh water and check the unit for any signs of obvious damage. Pay particular attention to the transducer head and free any organic matter which has become trapped. Once the unit is clean; dry thoroughly and place in storage container.

### 6.2. If storing the sonar for extended periods

Make sure that the sonar is completely dry (if necessary leave to dry in air before stowing). Pack into storage container along with several pouches of silica gel.

### 6.3. SeaKing regular maintenance

#### General Guidelines



#### Caution

It is essential to have a regular maintenance schedule so that any defects arising from corrosion or erosion can be spotted early and corrected before they cause severe damage to the unit. It is recommended that the unit is annually serviced and can be returned to *Tritech International Ltd* for this purpose

Competent, trained, personnel can perform regular preventative maintenance on these units. Contact *Tritech International Ltd* for more details on the training courses available.

#### Servicable Items

The standard Trittech SeaKing unit has several user serviceable items, all located on the connector endcap.



Exploded view diagram	Item Part Number	Description
	3	S01037 Body O-ring
	4	S01204 Connector Endcap ASSY
	5	S00009 0161-16 O-ring
	6	S01252 Endcap puller
	7	S01299 M5x25 Endcap puller screw
	8	S00987 Waterblock
	9	S01182 Pressurised blanking cap ASSY
	10	S01038 Retaining O-ring
	11	S01023 Retaining ring



**Note**

The part numbers expressed are subject to change.



**Note**

Alternative configurations may have additional serviceable items, if in doubt please contact *Tritech International Ltd* to establish the correct service routine.

The o-ring seals should be regularly inspected, cleaned and lubricates with the appropriate greasing compound. The body of the unit should also be inspected for any obvious signs of corrosion, especially in mating surfaces (such as the waterblock).

**6.3.1. Disassembly of the SeaKing unit**



**Warning**

In the unlikely event that the subsea housing has suffered water ingress at depth there may be internal pressurization. This could forcibly eject the end-cap when the lock ring is removed.

If wishing to dismantle the unit, for any reason, due care and attention should be taken to prevent damage or injury.



### Important

The steps outlined here will expose sensitive electronic equipment and so appropriate steps should be taken to prevent any static discharge occurring which may harm the equipment.



### Caution

Servicing of the SeaKing unit should only be carried out by competent personnel in a dry, clean environment with full ESD precautions.

#### Service tools required

- Clean absorbent wipes
- Silicon grease MS-111 lubricant (or equivalent)
- A M3 Allen Key or Hex driver
- A 5.5mm spanner, or nut spinner
- A small nose flush plier, or M2.5 spanner

#### Procedure

1. Rinse the unit and connector in fresh water and dry with absorbent wipes
2. Using the M3 Allen key, loosen each of the retaining screws of the Pressurised blanking cap (if present)
3. Using the M3 Allen key, loosen each of the retaining screws of the MAIN and AUX (if present) waterblocks. Each screw should be loosened by a quarter turn in order to prevent damage to the screw threads.
4. Remove the connector endcap locking ring
5. Using the endcap puller, pull the connector endcap off the unit
6. The electronics block will then slide out of the housing attached to the connector endcap.
7. On the top of the electronics block, use the 5.5mm spanner to carefully remove the two retaining nuts and the short nose flush pliers to remove the two bullet posts
8. In turn, remove each PCB and each set of four stand off posts underneath until only the PCB closest to the endcap remains – the COM PCB
9. Remove the last PCB and then unscrew the four guide posts from the connector endcap

Once fully disassembled, inspect the various o-ring seals and sealing surfaces for signs of damage and corrosion. Pitting and corrosion within an o-ring sealing area can cause a unit to lose integrity and lead to water ingress and significant damage.

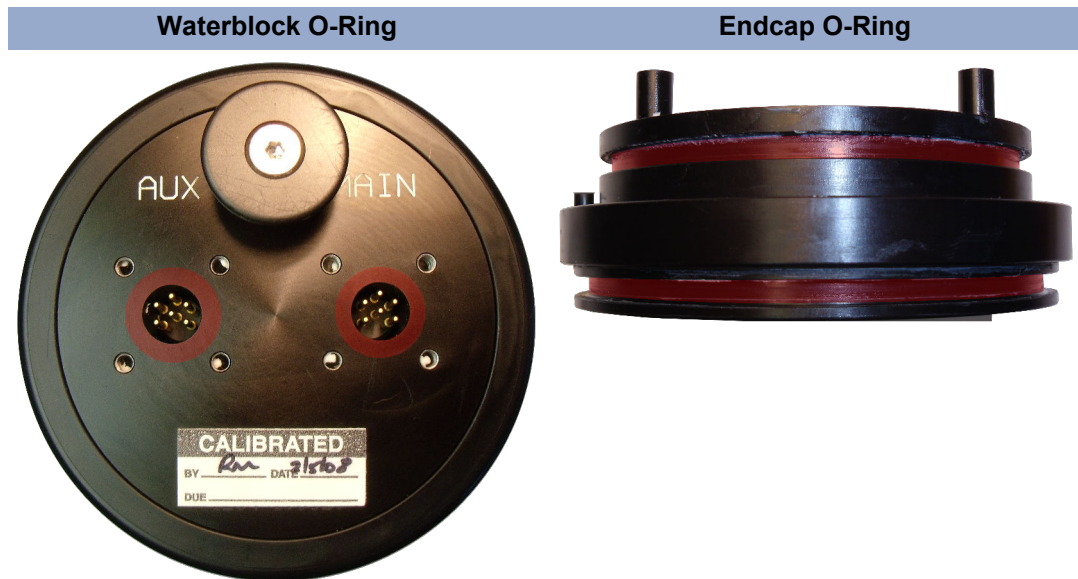

The highlighted areas on the images above are the critical sealing areas that should have no signs of corrosion. Corrosion in these areas will necessitate the replacement of the connector endcap.

### 6.3.2. Reassembly of the SeaKing unit



#### Important

The steps outlined here will expose sensitive electronic equipment and so appropriate steps should be taken to prevent any static discharge occurring which may harm the equipment.



#### Caution

Servicing of the SeaKing unit should only be carried out by competent personnel in a dry, clean environment with full ESD precautions.

Service tools required

- Clean absorbent wipes
- Silicon grease MS-111 lubricant (or equivalent)
- A M3 Allen Key or Hex driver
- A 5.5mm spanner, or nut spinner
- A small nose flush plier, or M2.5 spanner

*Procedure*

1. Carefully clean all parts and check for damage.
2. Inspect o-ring seals and replace if necessary.
3. Screw in the four guide posts onto the connector endcap
4. Fit the COM PCB and a set of four stand off posts
5. Refit each PCB and set of stand off posts

6. On the top most PCB, locate the two hexagonal pictures on the PCB
7. Using the 5.5mm spanner secure the retaining nuts at these locations
8. Using the short nose flush pliers, fit the bullet post at the remaining points
9. Carefully insert the electronics block back into the Body tube, ensuring that the dowel pin on the connector endcap lines up with the recess point on the Body tube
10. Fit the connector endcap locking ring
11. Using the M3 Allen key, fit the MAIN and AUX (if applicable) waterblocks. Each of the waterblock screws should be tightened, in turn, by a quarter turn until the waterblock is flush and level to the connector endcap
12. Using the M3 Allen Key, fit the Pressurised blanking cap (if applicable) either directly onto the AUX port, or on the AUX waterblock if it not to be used.
13. Visually inspect the unit to ensure that all surfaces have mated correctly

## 6.4. Super SeaPrince regular maintenance

### General Guidelines



#### Caution

It is essential to have a regular maintenance schedule so that any defects arising from corrosion or erosion can be spotted early and corrected before they cause severe damage to the unit. It is recommended that the unit is annually serviced and can be returned to *Tritech International Ltd* for this purpose

Competent, trained, personnel can perform regular preventative maintenance on these units. Contact *Tritech International Ltd* for more details on the training courses available.

### Servicable Items

The standard Super SeaPrince has very few user servicable parts.

Item	Part Number	Description
1	S00009	0161-16 O-ring
2	S00987	Waterblock
3	S01182 ASSY	Pressurised blanking cap

The o-ring seals should be regularly inspected, cleaned and lubricated with the appropriate greasing compound. The body of the unit should also be inspected for any obvious signs of corrosion, especially in mating surfaces (such as the waterblock).

### 6.4.1. Disassembly of the Super SeaPrince unit



#### Warning

In the unlikely event that the subsea housing has suffered water ingress at depth there may be internal pressurization. This could forcibly eject the end-cap when the lock ring is removed.

If wishing to dismantle the unit, for any reason, due care and attention should be taken to prevent damage or injury.



#### Important

The steps outlined here will expose sensitive electronic equipment and so appropriate steps should be taken to prevent any static discharge occurring which may harm the equipment.



#### Caution

Servicing of the SeaKing unit should only be carried out by competent personnel in a dry, clean environment with full ESD precautions.

Service tools required

- Clean absorbent wipes
- Silicon grease MS-111 lubricant (or equivalent)
- A M3 Allen Key or Hex driver

*Procedure*

1. Rinse the unit and connector in fresh water and dry with absorbent wipes
2. Using the M3 Allen key, loosen each of the retaining screws of the Pressurised blanking cap (if present)
3. Using the M3 Allen key, loosen each of the retaining screws of the MAIN and AUX (if present) waterblocks. Each screw should be loosened by a quarter turn in order to prevent damage to the screw threads.

Once fully disassembled, inspect the various o-ring seals and sealing surfaces for signs of damage and corrosion. Pitting and corrosion within an o-ring sealing area can cause a unit to lose integrity and lead to water ingress and significant damage.

#### Waterblock O-Rings

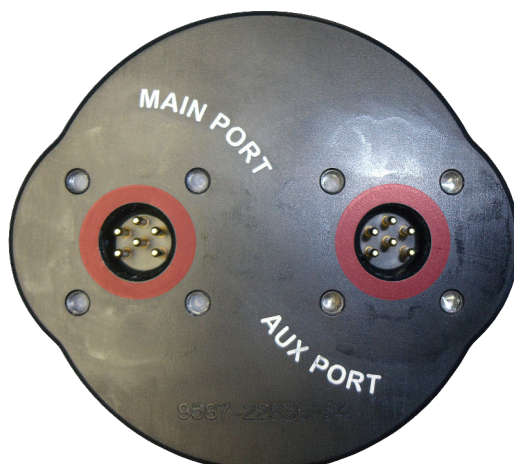

The highlighted areas on the image above are the critical sealing areas that should have no signs of corrosion. If corrosion is present within either of these areas, please contact *Tritech International Ltd* to arrange for immediate servicing of your Super SeaPrince unit.

## 6.4.2. Reassembly of the Super SeaPrince unit



### Important

The steps outlined here will expose sensitive electronic equipment and so appropriate steps should be taken to prevent any static discharge occurring which may harm the equipment.



### Caution

Servicing of the SeaKing unit should only be carried out by competent personnel in a dry, clean environment with full ESD precautions.

Service tools required

- Clean absorbent wipes
- Silicon grease MS-111 lubricant (or equivalent)
- A M3 Allen Key or Hex driver

*Procedure*

1. Carefully clean all parts and check for damage.
2. Inspect o-ring seals and replace if necessary.
3. Using the M3 Allen key, fit the MAIN and AUX (if applicable) waterblocks. Each of the waterblock screws should be tightened, in turn, by a quarter turn until the waterblock is flush and level to the connector endcap
4. Using the M3 Allen Key, fit the Pressurised blanking cap (if applicable) either directly onto the AUX port, or on the AUX waterblock if it not to be used.
5. Visually inspect the unit to ensure that all surfaces have mated correctly

## 7. Troubleshooting

Continuous Status "Timeout 2" message	No communication with the device  (In this case the Node number of the device is 2). Check the power and communications links to the sonar head for continuity and for correct polarity, voltage and ensure that the power supply can provide sufficient current to power all devices. If internal damage is suspected, contact <i>Tritech International Ltd</i> for service and repair options.
Status "Centre Err 2" message	The head has lost its bearing during the scan.  This may be a result of a sudden knock or collision that may have damaged the transducer and/or stepper motor shaft. The transducer will correct its bearing at the end of the scan but if the error message is repeated then there has been damage to the transducer or stepper motor.
Sonar head rotates but no targets observed	Incorrect settings or malfunction.  Listen to sonar head in air. If it "clicks" audibly then the transmitter circuit is OK. Check that the sonar was not operated in clear water where there were no sonar targets. Check the gain control is responding and not set at a minimum.
No seabed sonar targets observed	Sonar at incorrect height above seabed.  SeaKing sonars have a vertical beam width of 20 - 40° about a centre line (plus and minus 10 - 20°) so ensure that the head is positioned sufficiently close to the seabed.

## Appendix A. Help & Support

First please read this manual thoroughly (particularly the Troubleshooting section, if present). If a warranty is applicable, further details can be found in the Warranty Statement, 0080-STF-00139, available upon request.

*Tritech International Ltd* can be contacted as follows:

	Mail	<i>Tritech International Ltd</i> Peregrine Road Westhill Business Park Westhill, Aberdeenshire AB32 6JL, UK
	Telephone	++44(0)1224 744 111
	Email	<a href="mailto:tritech-support@moog.com">tritech-support@moog.com</a>
	Website	<a href="http://www.moog.com/tritech">www.moog.com/tritech</a>

Prior to contacting *Tritech International Ltd* please ensure that the following is available:

1. The Serial Numbers of the product and any *Tritech International Ltd* equipment connected directly or indirectly to it
2. Software or firmware revision numbers
3. A clear fault description
4. Details of any remedial action implemented



### Contamination

If the product has been used in a contaminated or hazardous environment you *must* de-contaminate the product and report any hazards *prior* to returning the unit for repair. *Under no circumstances should a product be returned that is contaminated with radioactive material.*

The name of the organisation which purchased the system is held on record at *Tritech International Ltd* and details of new software or hardware packages will be announced at regular intervals. This manual may not detail every aspect of operation and for the latest revision of the manual please refer to [www.moog.com/tritech](http://www.moog.com/tritech)

*Tritech International Ltd* can only undertake to provide software support of systems loaded with the software in accordance with the instructions given in this manual. It is the customer's responsibility to ensure the compatibility of any other package they choose to use.



## Appendix B. Specification

### B.1. SeaKing

#### B.1.1. SeaKing Dimensions

##### 4000m Rating (standard)

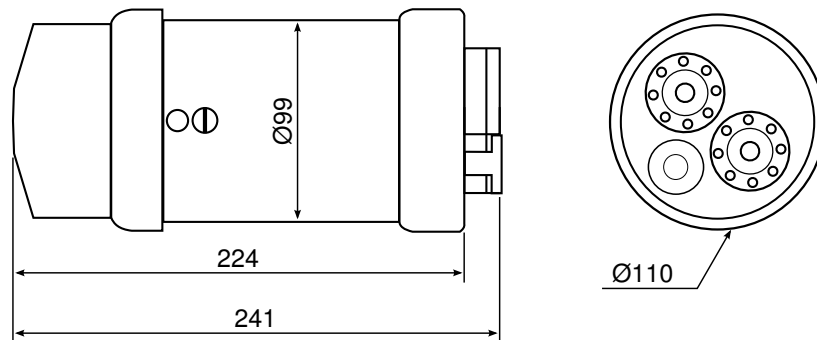

Not to scale, dimensions in mm.

Shown with *Tritech International Ltd* waterblock and 6 pin connector but others are available. See Appendix E, *SeaKing Sonar & Profiler Connector Options* for more details and part numbers.

##### 6800m Rating

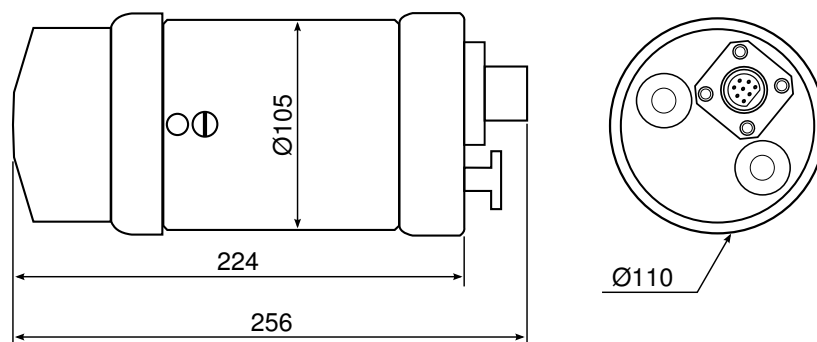

Not to scale, dimensions in mm.

Shown with a SeaConn 5506 connector but others are available. See Appendix E, *SeaKing Sonar & Profiler Connector Options* for more details and part numbers.

### B.1.2. SeaKing Physical Properties

Depth rating	4000m standard 6800m optional
Weight in air	3kg (aluminium)
Weight in water	1.4kg (aluminium)
Materials	Anodised aluminium alloy (6Al4V Titanium alloy optional)
Operating temperature	-10 to 35°C
Storage temperature	-20 to 50°C

### B.1.3. SeaKing Acoustic Properties

Property	Low Frequency	High Frequency
Frequency	CHIRP centred on 325kHz	CHIRP centred on 650kHz
Beamwidth	20° vertical, 3.0° horizontal	40° vertical, 1.5° horizontal
Pulse length	400µs	200µs
Maximum range	300m	100m
Minimum range	0.4m	
Range resolution	approximately 15mm (minimum)	
Source level	210dB re 1µPa at 1m	

### B.1.4. SeaKing Display Characteristics

Mechanical resolutions	0.45°, 0.9°, 1.8°, 3.6°
Scanned sector	Variable up to 360°
Continuous 360°	Yes
Sector offset mode	Yes

### B.1.5. SeaKing Electrical and Communication

Connector options	Tritech 6-pin (standard) Others available on request
Power requirements	20 to 72V DC at 12W AUX port voltage equal to Main port supply
Data communication	Ethernet, ARCNET, RS232, RS485
Data rate	Ethernet: 100Mbps (minimum) ARCNET: 156kbit·s <sup>-1</sup> (maximum) RS232 & RS485: 115.2kBd (maximum)
Drive capability (ARCNET only)	1500m at 156kbit·s <sup>-1</sup> 2500m at 78kbit·s <sup>-1</sup>
Isolation (ARCNET only)	Transformer Isolated 1500V

## B.2. SeaPrince

### B.2.1. SeaPrince Dimensions

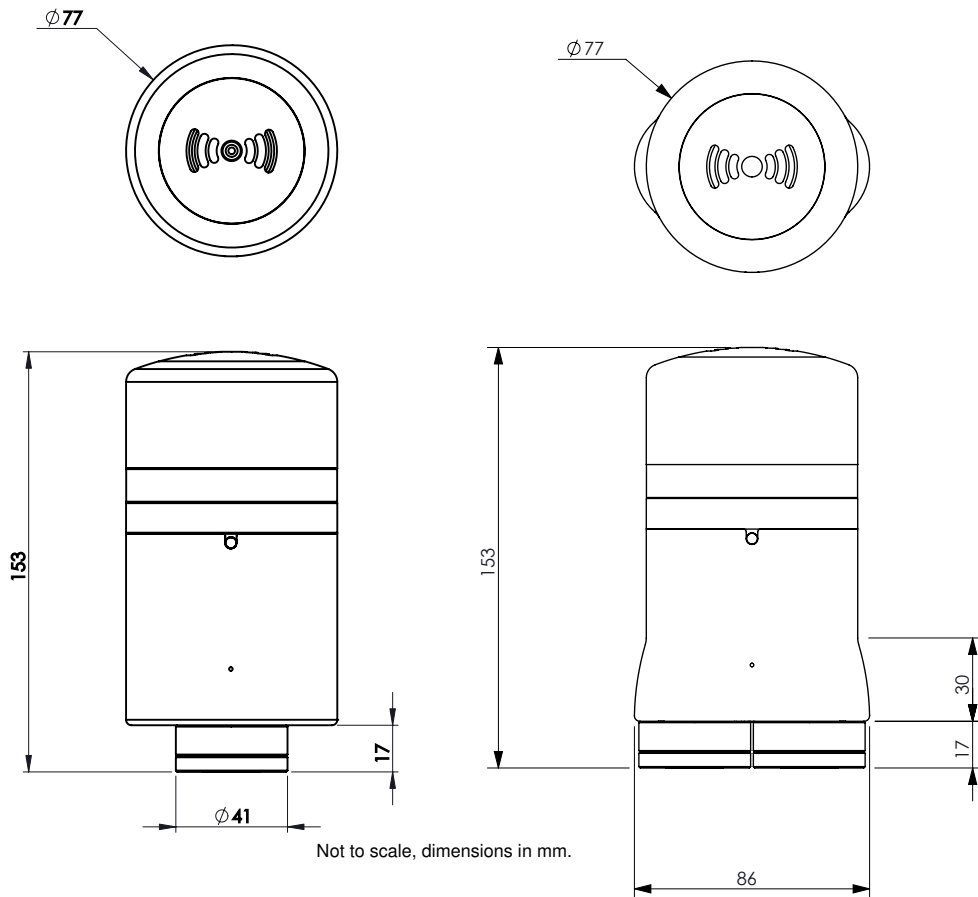

#### Note

Single port model is part number 8249 and dual port is 8250 (a high voltage version is available which is 8250 48V).

### B.2.2. SeaPrince Physical Properties

Depth rating	4000m
Weight in air	1kg (single port), 1.05kg (dual port)
Weight in water	0.39kg (single port), 0.44kg (dual port)
Operating temperature	-10 to 35°C
Storage temperature	-20 to 50°C



#### Note

DST SeaPrince units manufactured prior to 2011 have an overall length of 146mm and a maximum diameter of 74.5mm (Single Port) or 86mm (Dual Port model). If you are unsure which sonar you have please contact *Tritech International Ltd* support.

### B.2.3. SeaPrince Acoustic Properties

Operating frequency	Maximum bandwidth 500kHz to 900kHz (default of 675kHz)
Beamwidth	38° vertical, 2.3° horizontal
Maximum range	100m
Minimum range	1m

### B.2.4. SeaPrince Display Characteristics

Mechanical resolutions	0.45°, 0.9°, 1.8°, 3.6°
Scanned sector	360°
Continuous 360°	Yes
Sector offset mode	Yes

### B.2.5. SeaPrince Electrical and Communication

Power requirement	12 to 36V DC at 10W (18 to 56V DC optional)
Communication Protocols	ARCNET, RS232, RS485
Data rate	ARCNET: 156kbit·s <sup>-1</sup> (maximum) RS232 & RS485: 115.2kBd (maximum)
Drive capability (ARCNET only)	1500m at 156kbit·s <sup>-1</sup> 2500m at 78kbit·s <sup>-1</sup>
Isolation (ARCNET only)	Transformer Isolated 1500V

## Appendix C. ARCNET Termination

Depending on the cable length the ARCNET communication link requires a termination resistor to be installed at each end of the umbilical cable. Normally this is supplied fitted within the ARCNET cable DA-15 or within the SCU/SeaHub at the surface and is left for the user to fit at the sub-sea end in a convenient junction box or by use of a special waterblock.

The purpose of these terminations is to attenuate any electrical interference or "reflections" which may occur due to an impedance mis-match and the overall aim is to improve signal quality and negate any effects which might otherwise be felt by other sources of impedance such as from the cable itself.

The diagram below shows best practice to use when installing termination resistors on an ARCNET network of *Tritech International Ltd* sonar products.



### Note

A special yellow waterblock is available from *Tritech International Ltd* which contains an in-line impedance of  $39\Omega$  which will enable quick and easy installation of the subsea termination resistor.

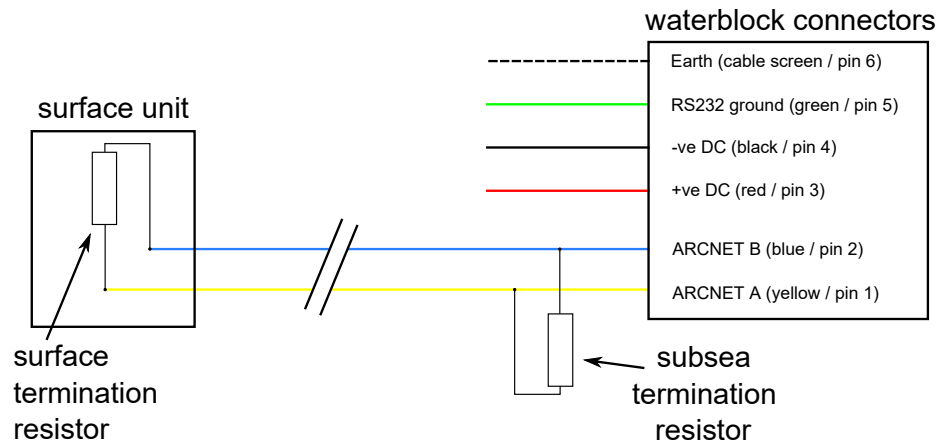

Cable length	Termination	Baud rate setting
Less than 100m	Single $39\Omega$ subsea resistor	Normal baud rate
100-1200m	$270\Omega$ at surface and $39\Omega$ subsea	Normal baud rate
1200-2500m	$270\Omega$ at surface and $39\Omega$ subsea	Half baud rate



### Note

If there is more than one sensor connected then the sub-sea resistor should be fitted at the junction box or splice of the cable.

## Appendix D. CHIRP Signal Processing

There are several advantages of *Tritech International Ltd* Digital Sonar Technology (DST) which allows the use of CHIRP signal processing technology to improve the images generated by the sonar.

In monotonic (single frequency burst) sonar, the range resolution is determined by the length of the transmitted pulse. The smaller the pulse, the greater the resolution achievable and vice-versa. The smallest pulse length is typically 50 micro seconds and velocity of sound in water is approximately 1500 metres/second which gives a range resolution of 37.5mm. This result determines the ability to resolve separate targets.

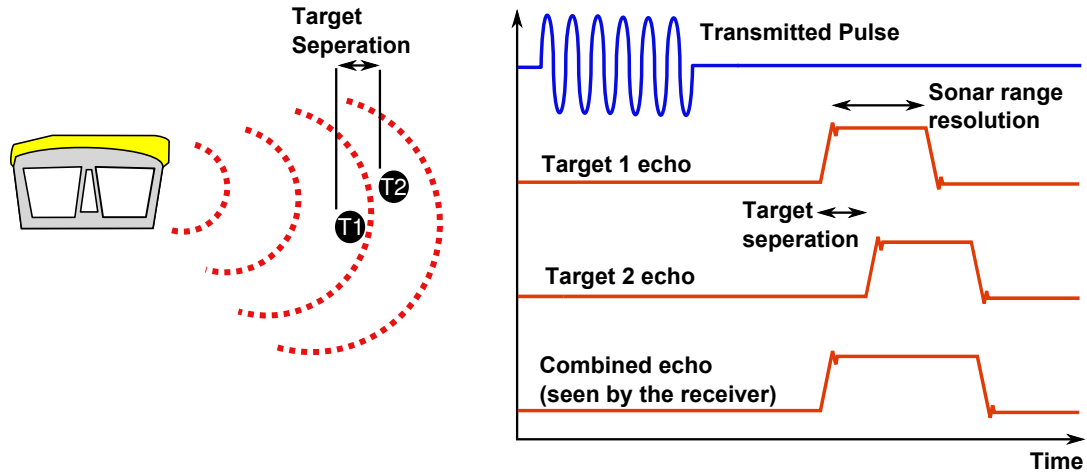

Using the example above, if two targets are less than 37.5mm apart then they cannot be distinguished from each other. The net effect is that the system displays a single large target, rather than multiple smaller targets.

CHIRP signal processing overcomes these limitations by sweeping the frequency within the burst over a broad range of frequencies throughout the duration of transmission pulse. This creates a signature acoustic pulse - the sonar knows what was transmitted and when. Using pattern matching technology, it can now look for its own unique signature being echoed back from targets.

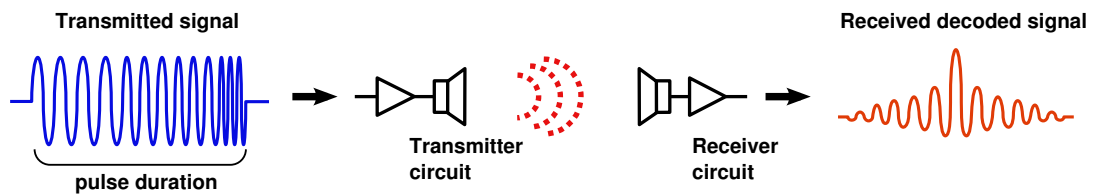

In a CHIRP system, the critical factor determining range resolution is the bandwidth of the CHIRP pulse which means the range resolution is given by:

$$\text{Range resolution} = \frac{\text{velocity of sound}}{2 \times \text{bandwidth}}$$

The bandwidth of a typical *Tritech International Ltd* CHIRP system is 50kHz.

With velocity of sound in water of 1500m/s this gives a new range resolution of 15mm.

This time, when two acoustic echoes overlap, the signature CHIRP pulses do not merge into a single return. The frequency at each point of the pulse is different, and the sonar is able to resolve the two targets independently.

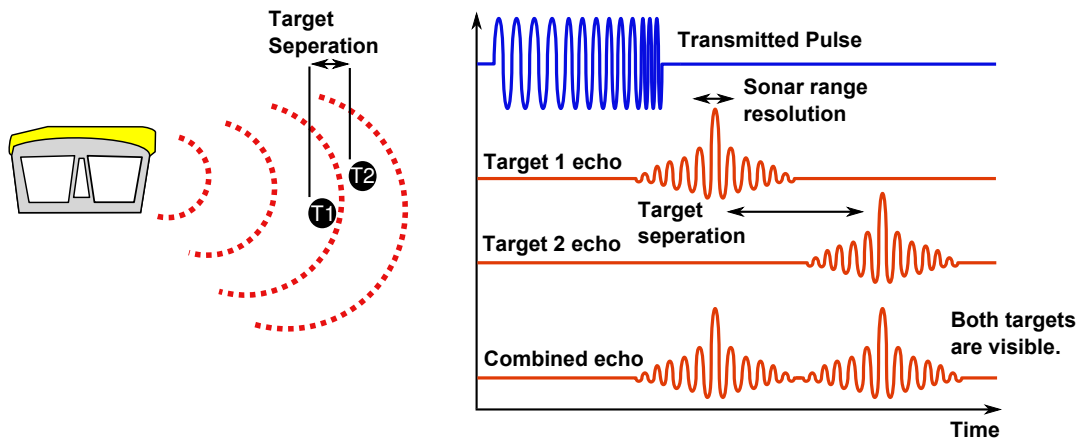

The response from the pattern-matching algorithms in the sonar means that the length of the acoustic pulse no longer affects the amplitude of the echo on the sonar display. Longer transmissions (and operating ranges) can be achieved without a loss in range resolution.

CHIRP gives additional improvements in background noise rejection, as the sonar is only looking for a swept frequency echo and can remove random noise or out-of-band noise.

## Appendix E. SeaKing Sonar & Profiler Connector Options

The SeaKing sonar can be fitted at the factory with a variety of connector options to allow quick and easy integration into an existing network or sonars or other ROV equipment. For more details contact *Tritech International Ltd.*

Head part no.	Sonar Type	Depth Rating	Frequency (kHz)	Connector
04127	SSK DFP, V5	4000m	580, 1210	Tritech 6 pin
06332	SSK DFS, V6	4000m	325, 675	Tritech 6 pin
07525	SSK DFS, V6	4000m	325, 675	Burton Seaconn 5506-1508
08540	SSK DFS, V6	6800m	385, 725	Burton Seaconn 5506-1508
07525B	SSK DFS, V6	4000m	325, 675	Burton Seaconn 5506-1508
06756	SSK DFP, V5	4000m	580, 1210	Burton Seaconn 5506-1508
06731	SK DFP, V5	6800m	580, 1200	Burton Seaconn 5506-1508
08652	SSK DFS, V6	4000m	325, 675	Burton Seaconn 5506-1508
08803	SK DFS, V6	6800m	385, 725	Burton Seaconn 5506-1508
07578	SSK DFS, V6	4000m	325, 675	Schilling SeaNet
08348	SSK DFS, V5	4000m	325, 675	SubConn BH8M
07765	SSK DFS, V6	4000m	325, 675	SubConn BH6M
09177	SK DFS, V6	6800m	385, 725	SubConn BH6M
08768	SK DFS, V6	6800m	325, 675	SubConn MCBHRA5M
08761	SK DFS, V6	6800m	385, 725	DG O'Brien 128
<i>SK = SeaKing, SSK = Super SeaKing, DFS = Dual Frequency Sonar, DFP = Dual Frequency Profiler</i>				



## Appendix F. Super SeaPrince External Reset

In the event of losing communications with the Super SeaPrince and being unable to re-establish them it is possible to reset the unit to a preset standard.

Item changed	Default value	Item changed	Default value
Main Port Comms	RS232	Aux Port Comms	RS232
Main Port Baud (Hi/Lo)	115200 / 9600	Aux Port Baud (Hi/Lo)	9600 / 9600
Main Port Parity (Hi/Lo)	None	Aux Port Parity (Hi/Lo)	None
Main Port Data-bits (Hi/Lo)	8	Aux Port Data-bits (Hi/Lo)	8
ARCNET Baud (Hi/Lo)	156 / 78	Half-Duplex	False
ARCNET Sens (Hi/Lo)	Neutral	Aux. Comms rate	1000ms
ARCNET Timeout	11 [Normal] (ET3)	Disable AutoComms	True
		COMV6 Fitted	True



### Note

In the event of other items, such as the operating frequencies, being changed contact *Tritech International Ltd* for further advice and instruction.

In order to complete the reset process, the following steps will apply:

1. Ensure an RS232 COM Port is available, has been enabled within Seanel Pro and is set for 115200 Baud.
2. Using an appropriate test cable, connect the Sonar to a suitable power supply and topside control unit but do not apply power yet.
3. Locate the reset point on the body of the Super SeaPrince.



4. Place a magnet onto the reset point and apply power to the unit. Do not remove the magnet until the unit has fully powered up for 5 seconds.

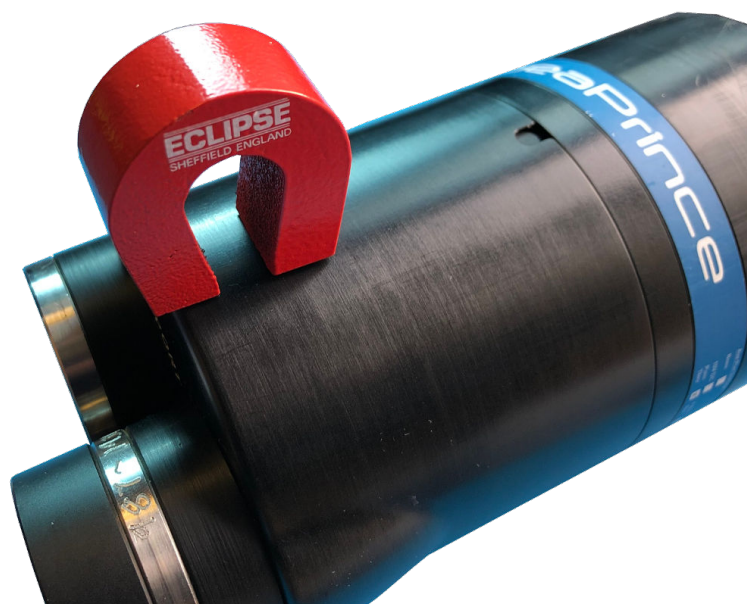

### Note

The internal reset hall effect is south sensitive. This means that the magnet should be orientated as per the image above with the *SE* side of the *ECLIPSE* logo over the dimple on the body tube.

5. Remove the magnet and power down the Sonar
6. Power up the Sonar
7. The Sonar should now be visible within the Node table of Seanet Pro. Enter the node `Setup` page and adjust the operation of the unit to suit.

The unit can now be re-configured to the desired communications. Please refer to the *Arcnet and Serial Communications Manual - 0374-SOM-00003* for more information, or contact *Tritech International Ltd.*

## Appendix G. V6 COM PCB Reset

In the unlikely event that communication to a SeaKing becomes impossible, units fitted with a V6 COM PCB can be reset to a pre-determined standard using the magnetic reset function

The default values that will be applied to the SeaKing unit for the magnetic reset are as follows:

Item changed	Default value	Item changed	Default value
Main Port Comms	RS232	Aux Port Comms	RS232
Main Port Baud (Hi/Lo)	115200 / 9600	Aux Port Baud (Hi/Lo)	9600 / 9600
Main Port Parity (Hi/Lo)	None	Aux Port Parity (Hi/Lo)	None
Main Port Data-bits (Hi/Lo)	8	Aux Port Data-bits (Hi/Lo)	8
ARCNET Baud (Hi/Lo)	156 / 78	Half-Duplex	False
ARCNET Sens (Hi/Lo)	Neutral	Aux. Comms rate	1000ms
ARCNET Timeout	11 [Normal] (ET3)	Disable AutoComms	True
		COMV6 Fitted	True

### Main setup changes

### Baud rate changes

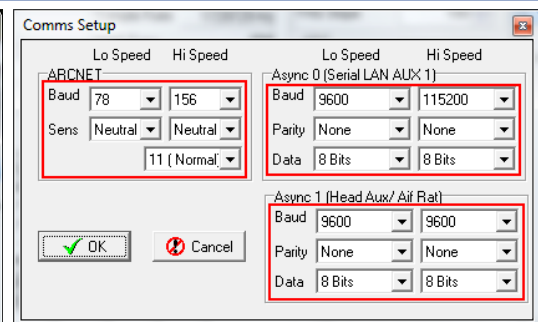
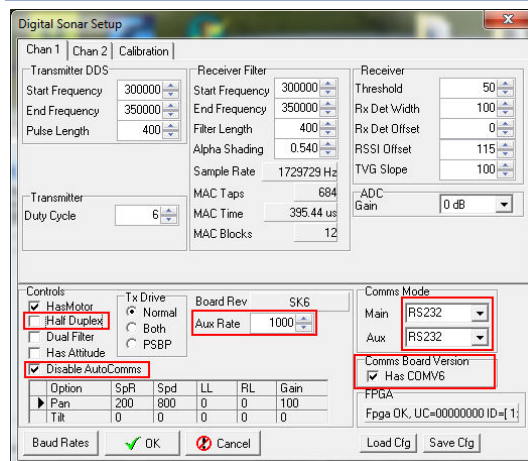

Within the standard SeaKing accessory kit there is a strong magnet supplied specifically for this purpose.



In order to complete the reset process, the following steps will apply:

1. Ensure an RS232 COM Port is available, has been enabled within Seagnet Pro and is set for 115200 Baud.
2. Using an appropriate test cable, connect the Sonar to a suitable power supply and topside control unit but do not apply power yet.
3. Place a magnet onto the reset point and apply power to the unit. Do not remove the magnet until the unit has fully powered up for 5 seconds.



### Note

The internal reset hall effect is south sensitive. This means that the magnet should be orientated as per the image above with the *SE* side of the *ECLIPSE* logo over hall effect.

4. Remove the magnet and power down the Sonar
5. Power up the Sonar
6. The Sonar should now be visible within the Node table of Seagnet Pro. Enter the node *Setup* page and adjust the operation of the unit to suit.

The unit can now be re-configured to the desired communications. Please refer to the *Arcnet and Serial Communications Manual - 0374-SOM-00003* for more information, or contact *Tritech International Ltd.*

---

## Glossary

AIF	Originally "Acoustic Interface" but also used to refer to "ARCNET Interface" in which case it can refer to either the interface port on a SeaHub or SCU or to the expansion card available for installation into a computer.
ARCNET	Attached Resource Computer NETwork - a network protocol similar to Ethernet but with the advantage of working over much longer ranges.
CD-ROM	Compact Disc - Read Only Memory
DA-15	A 15 pin D shaped connector used mainly for the ARCNET connection on the SCU and SeaHub.
DC	Direct Current
DST	Digital Sonar Technology
GPS	Global Positioning System.
LAN	Local Area Network
LED	Light Emitting Diode
PC	Personal Computer
PCB	Printed Circuit Board
PSU	Power Supply Unit
ROV	Remotely Operated Vehicle
RS232	Traditional name for a series of standards for serial binary data control signals.
RS485	A standard for defining the electrical characteristics of drivers and receivers for use in a balanced digital multipoint system (also known as EIA-485).
RX	Receive (data)
SCU	Surface Control Unit - a specially manufactured computer which is rack mountable and capable of processing the data from the sonar equipment running either Windows® XP Embedded or Windows® 7 and Seanet Pro or Gemini software.
SeaHub	An alternative to using a Seanet SCU, this device connects to a laptop or PC via USB interface, essentially this takes the signal from the sonar (in RS232, RS485 or ARCNET) and converts it into a signal suitable for the USB port of the computer.
SeaKing	A specific sonar produced by <i>Tritech International Ltd</i> but also refers to the family of sonar equipment manufactured by <i>Tritech International Ltd</i> comprising of the SeaKing, SeaKing DST scanning and profiling sonars and the Hammerhead survey sonar.
Seanet Pro	The software supplied by <i>Tritech International Ltd</i> which is capable of running all the sonar devices.
SeaPrince	A more compact sonar than the SeaKing which operates at a single fixed frequency

Tritech waterblock	The 4000m depth rated connector developed by <i>Tritech International Ltd</i> for their subsea equipment.
TX	Transmit (data)
USBL	Ultra Short Base Line (positioning system)