

AnchorZip10

Product Manual

0712-SOM-00001, Issue: 03



© Trittech International Ltd

The copyright in this document is the property of Trittech International Ltd. The document is supplied by Trittech International Ltd on the understanding that it may not be copied, used, or disclosed to others except as authorised in writing by Trittech International Ltd.

Trittech International Ltd reserves the right to change, modify and update designs and specifications as part of their ongoing product development programme.

All product names are trademarks of their respective companies.

Table of Contents

Help & Support	4
Warning Symbols	5
1. Introduction	6
2. Specification	7
3. Installation	9
3.1. Mechanical	9
3.2. Water Hose	9
3.3. Hydraulic	10
4. Operation	14
4.1. Seating the Anchor	14
4.2. Suction Pressures in Shallow Water	15
4.3. Testing in Air	17
5. Maintenance	18
5.1. Pre-dive	18
5.2. Storage	18
5.3. Dismantling and Reassembly	19
6. Troubleshooting	26
A. Motor Protector Assembly Procedure	27
B. Performance Curves	29

Help & Support

First please read this manual thoroughly (particularly the Troubleshooting section, if present). If a warranty is applicable, further details can be found in the Warranty Statement, 0080-STF-00139, available upon request.

Tritech International Ltd can be contacted as follows:

	Mail	<i>Tritech International Ltd</i> Peregrine Road Westhill Business Park Westhill, Aberdeenshire AB32 6JL, UK
	Telephone	++44(0)1224 744 111
	Fax	++44(0)1224 741 771
	Email	support@tritech.co.uk
	Website	www.tritech.co.uk

Prior to contacting *Tritech International Ltd* please ensure that the following is available:

1. The Serial Numbers of the product and any *Tritech International Ltd* equipment connected directly or indirectly to it.
2. Software or firmware revision numbers.
3. A clear fault description.
4. Details of any remedial action implemented.



Contamination

If the product has been used in a contaminated or hazardous environment you *must* de-contaminate the product and report any hazards *prior* to returning the unit for repair. *Under no circumstances should a product be returned that is contaminated with radioactive material.*

The name of the organisation which purchased the system is held on record at *Tritech International Ltd* and details of new software or hardware packages will be announced at regular intervals. This manual may not detail every aspect of operation and for the latest revision of the manual please refer to www.tritech.co.uk

Tritech International Ltd can only undertake to provide software support of systems loaded with the software in accordance with the instructions given in this manual. It is the customer's responsibility to ensure the compatibility of any other package they choose to use.

Warning Symbols

Throughout this manual the following symbols may be used where applicable to denote any particular hazards or areas which should be given special attention:



Note

This symbol highlights anything which would be of particular interest to the reader or provides extra information outside of the current topic.



Important

When this is shown there is potential to cause harm to the device due to static discharge. The components should not be handled without appropriate protection to prevent such a discharge occurring.



Caution

This highlights areas where extra care is needed to ensure that certain delicate components are not damaged.



Warning

DANGER OF INJURY TO SELF OR OTHERS

Where this symbol is present there is a serious risk of injury or loss of life. Care should be taken to follow the instructions correctly and also conduct a separate Risk Assessment prior to commencing work.

1. Introduction

The AnchorZip10 is designed as a high efficiency water pump for moving large quantities of water at relatively low pressures. Its main application is in the deployment and retrieval of suction anchors and piles.

The AnchorZip10 has been designed to close couple to a flange plate to provide the minimum of flow restrictions. Switching the flow from suction to blowing is achieved by sliding the whole pump and motor body.

The AnchorZip10 also incorporates a suction break relief valve which, on the latest version, can be preset for pressures between 0.81 and 9.27 bar.

2. Specification

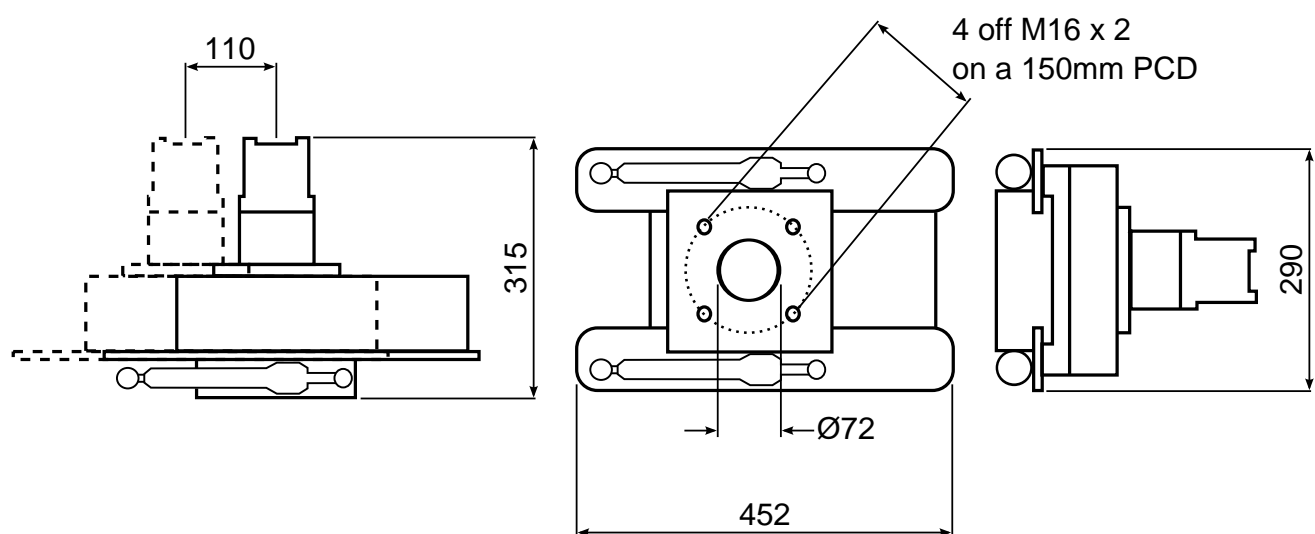

Not to scale, dimensions in mm.



Warning

Never use the same size fitting for pressure hoses and the case drain. If this is done there is significant risk of incorrect hook-up which will lead to pressure being applied to the motor casing and could result in an explosion and personal injury.

Hydraulic Motor Input	
Pressure	276 Bar (4000 psi)
Flow	70 litres/minute (15 gpm)

Weight and Materials	
Weight in air	30kg (66lbs)
Weight in water	14kg (31lbs)
Materials	Stainless Steel, Nylacast, UHMWPE

Actuator Input	
Min. pressure	70 Bar (1000 psi)
Max. pressure	240 Bar (3480 psi)

Hydraulic Fittings	
Motor A & B	No. 12 JIC male
Motor case drain	No. 6 JIC male
Actuator Connection	No. 4 JIC male

Output	
Typical differential pressure	Up to 9.5 Bar (140 psi)
Typical suction flow	Up to 80 cubic metres/hour at 7.5 Bar

Nozzle and Hose Dimensions	
Anchor port connection	Square flange with 72mm port
Minimum hose diameter	72mm (2.8")

Check Valve	
Norm.	Tritech Volvo Protector Assembly.
Alt.	Integrated Hydraulics FPR-1/22-0.5 (cracking pressure 50kPa)

3. Installation



Warning

Do not power the pump or hydraulic valve actuators until all hoses are properly connected to the pump.

There is a serious risk of injury to fingers if inserted into either the power water intake or the pump delivery port.

If undertaking any testing operations suitable guards and other safety measures must be in place.

3.1. Mechanical

The pump may be mounted in any orientation on the vehicle, but it is recommended that the connection to the anchor be as direct and short as possible to avoid inhibiting the flow. The mounting flange must be strong enough to carry the full weight of the pump.

The face of the pump carries 4 M16x2.0 mounting holes on a 150mm PCD. The pump mounting face is flat and the mating flange can either carry an o-ring or flat gasket. An o-ring seal groove is cut into the material for operating at higher pressures.

Thread engagement should be between 45mm and 48mm (maximum) and tightening torque should be in the range 45-55Nm (33-40lb_f·ft). Copper slip or similar grease should be used. Grade 70 or higher bolts are recommended.

Sufficient space should be allowed to permit the pump body including motor to slide through a distance of 110mm to switch between suction and blowing.

3.2. Water Hose

It is recommended that the pump is close coupled to the anchor by a direct flange fitting or short sections of hard hose. Any flexible hose used must be suitable rated for the expected pressure differentials. Large diameter flexible hose is liable to collapse under suction.

3.3. Hydraulic

Oil

The pump should be operated using a premium grade mineral based hydraulic oil of ISO VG 22 to 32.

Filtration

The hydraulic system filtration must be to a minimum of 10 μ m absolute standard. A 10 μ m nominal standard is regarded as inadequate.

The recommended filtration is UN elements produced by Pall Industrial Hydraulics Ltd. or equivalent products.

Hydraulic Hookup

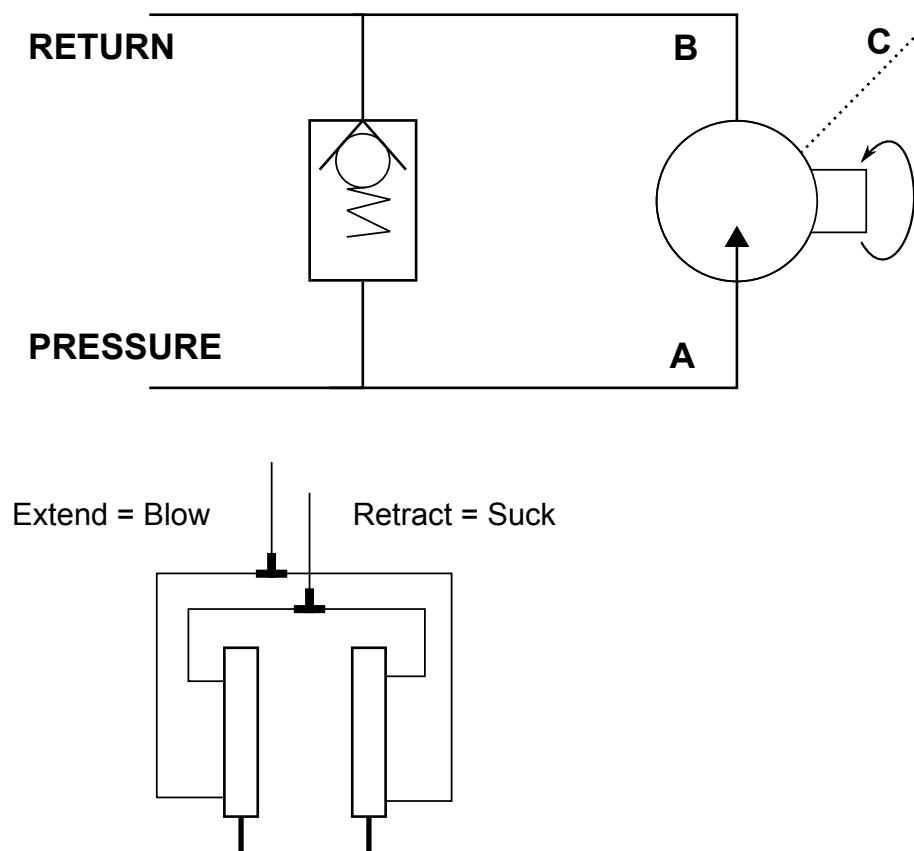

Figure 3.1. Hydraulic Hook-up Orientation



Note

If mounting restrictions dictate it is possible to rebuild the pump with "retract=blow" and "extend=suck". If required contact *Tritech International Ltd* Technical Support for more details.

Fittings

The standard fittings for the motor are detailed in Chapter 2, *Specification*.

The pump suction/blow selection is achieved by two hydraulic cylinders that must be connected in parallel from a single control valve. The cylinder bodies move with the pump body and flexible hoses are required.

The pump is configured for correct rotation when the hydraulic supply is connected to the "A" port of the Volvo motor and the return line to the "B" port (the impeller will not turn running in the reverse direction when a Trittech Volvo Protector is fitted).

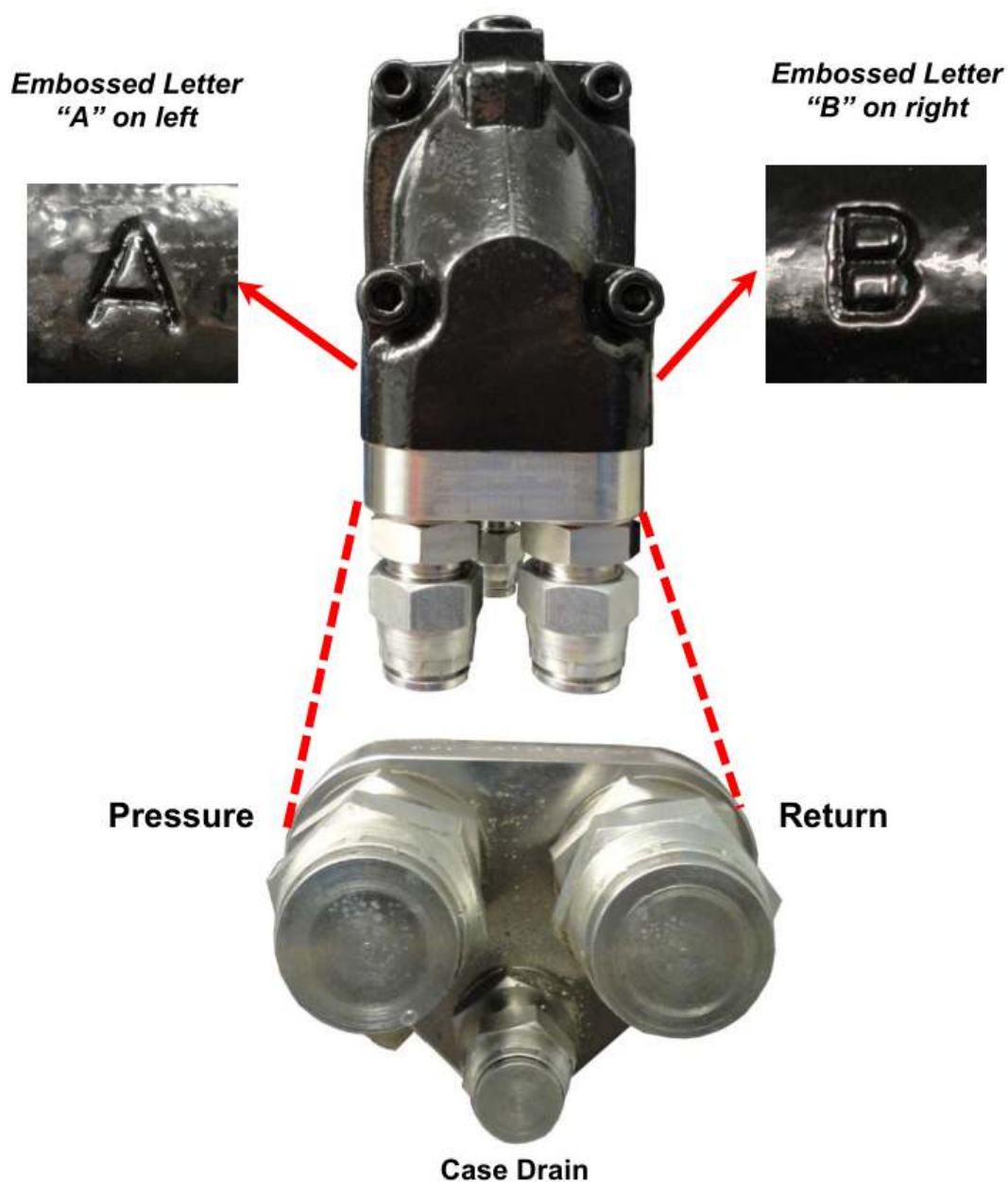

Figure 3.2. Motor viewed when fitted to AnchorZip10 with hydraulic fittings downwards

In order to avoid pressure losses it is mandatory that a minimum of $\frac{1}{2}$ inch bore pipework or hoses are used on the flow and return lines to the motor. $\frac{3}{4}$ inch or higher is recommended.

The drain line should not be connected to any return flow lines.



Warning

Self-sealing quick disconnect connectors should not be used on the drain line. Such connectors, if incorrectly fitted, may result in pressurisation of the motor casing which could fail explosively under pressure resulting in significant risk of personal injury.

To avoid shock loading the motor when the supply is stopped it is essential to provide the check valve as detailed in Chapter 2, *Specification*.

Required Hydraulic Flow

For the Volvo F11-10 motor the required flow may be chosen in conjunction with the performance curves supplied (Appendix B, *Performance Curves*). The maximum dead head water pressure is a function of the impeller speed which is directly related to the hydraulic flow.

If limiting dead head pressure is important to protect the structural integrity of the anchor then this may be achieved by limiting the hydraulic flow or by settling the suction relief valve (or by a combination of both). Limiting hydraulic flow will also reduce the maximum available water flow. This will be particularly significant if the flow limit is imposed by a restricting valve rather than a direct flow control valve since the hydraulic pressure will also be severely restricted.

Usually anchors pull in quite progressively so the differential pressure builds slowly and control can be achieved by manually stopping the pump when the anchor has reached the correct position or the pressure limit has been reached.

Hydraulic Motor Shaft Seals

The pumps are fitted with either an 'H' (red) or 'V' (brown) type seal. The type V is the standard seal and is high pressure, high temperature.

Replacement of seals with anything other than a genuine seal (or *Tritech International Ltd* supplied seal) will invalidate the warranty.

4. Operation

4.1. Seating the Anchor



Caution

Damage will occur to the impeller and pumping cavity if it is used to pump sharp silt or sand over an extended period.

This may occur if:

1. The seabed into which the anchor is inserted has erupted inside the anchor allowing significant quantities of material to be drawn down the sides and then through the interior of the anchor. This will mean that the anchor has been excavated into position rather than properly drawn in.
2. The anchor is drawn too far into the seabed and pumping is maintained.

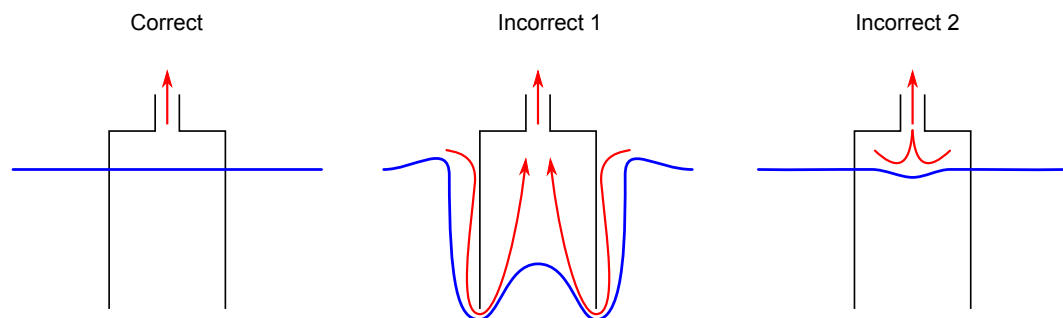

Figure 4.1. Correctly Seating the Anchor

Allowing this to happen is not only detrimental to the pump, but more seriously in the first instance is highly detrimental to the security of the installed anchor. In both cases installation will take much longer than normal.

4.2. Suction Pressures in Shallow Water

The impeller based AnchorZip10 pump relies on a head of water above the pump in order to achieve differential suction pressures otherwise cavitation damage will occur.

In Suction mode

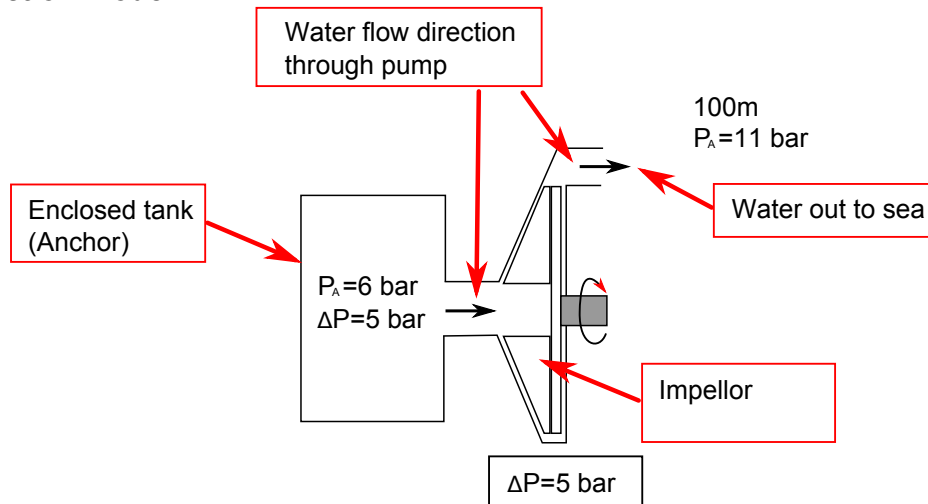

In Blowing mode

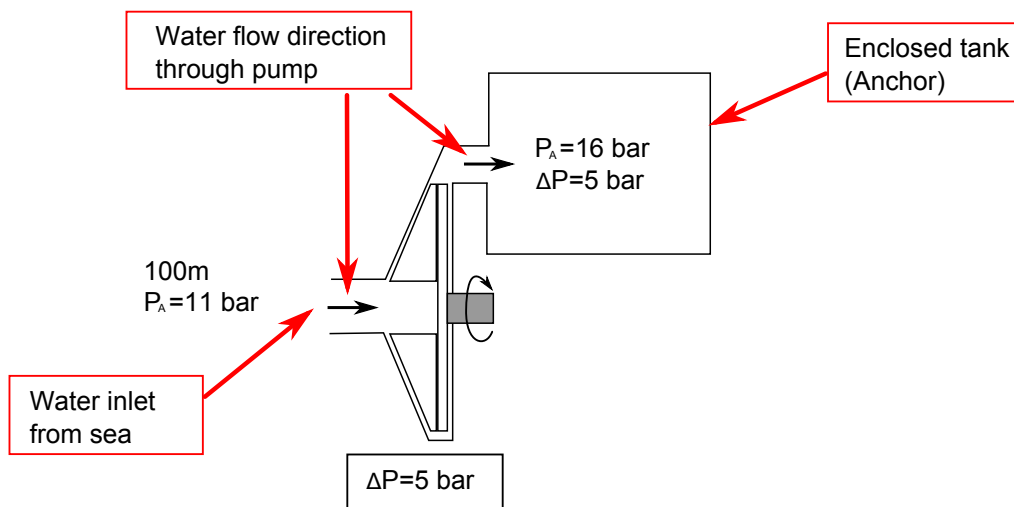

ΔP is differential pressure between ambient sea pressure and the enclosed tank.

P_A is the absolute pressure.

Figure 4.2. Performance in Shallow Water

Air

Water

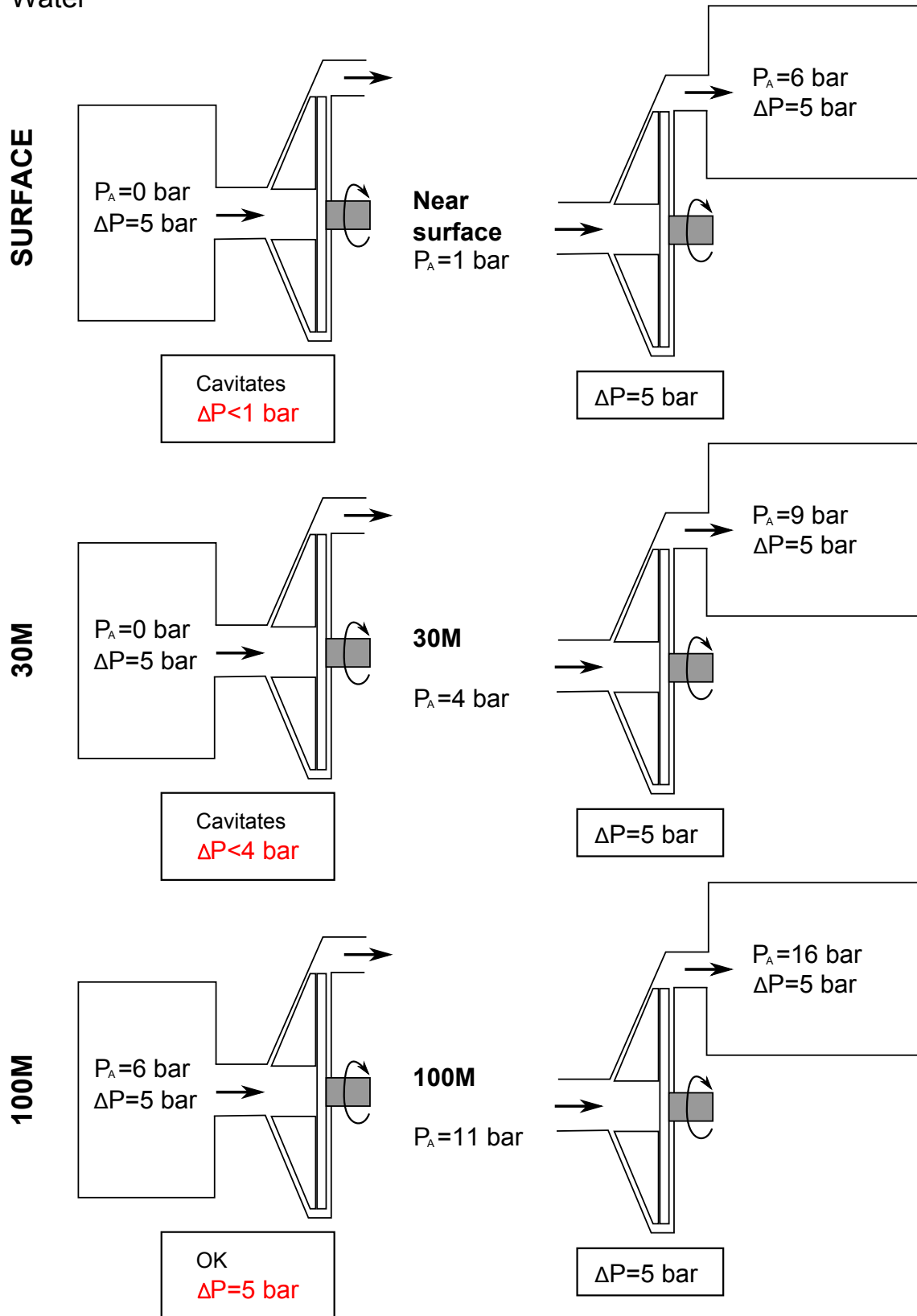

Figure 4.3. Depth versus suction capability

4.3. Testing in Air



Warning

Under no circumstances must the flow be allowed to exceed 70 litres per minute when testing in air.

There is no back pressure on the impeller to control its speed and many vehicle hydraulic systems are capable of higher deliveries when there are no thrusters running. Motor over-speed can cause a catastrophic failure

To avoid excessive wear and the possibility of damaging the impeller and body, the unit should not be run for extended periods out of the water (no more than about 30 seconds). This is especially true when the unit is new. Absence of water around the plastic removes the natural cooling mechanism and may result in the moving parts becoming misshapen due to the heat.

5. Maintenance



Warning

Do not power the pump or hydraulic valve actuators until all hoses are properly connected to the pump.

There is a serious risk of injury to fingers if inserted into either the power water intake or the pump delivery port.

If undertaking any testing operations suitable guards and other safety measures must be in place.

5.1. Pre-dive

Before use check the following:

- All hoses are secure
- All mountings are secure
- Clean water suction strainer is in place and clear



Note

If the vehicle is inactive for more than 48 hours run fresh water into the clean water suction strainer for a few minutes and then spin the hydraulic motor for about 15 seconds (taking care not to allow it to over-speed).

5.2. Storage

If the pump is removed from the vehicle, then the hydraulic ports should be blanked off with metal caps and the unit washed out with fresh water.

Leave the actuator valves in their retracted position.

Visually inspect the leading edges of the power pump impeller for damage and erosion.

Up to four blades may have leading edge damage of 5mm width and 4mm depth before replacement becomes essential.

If the majority of leading edges are eroded more than 3.5mm back from the bore of the inlet nozzle then consideration should be given to replacing the impeller.

5.3. Dismantling and Reassembly



Warning

Before carrying out any maintenance work on the pump unit it is essential to ensure that the vehicle hydraulic system has been de-pressurised including compensation pressure.

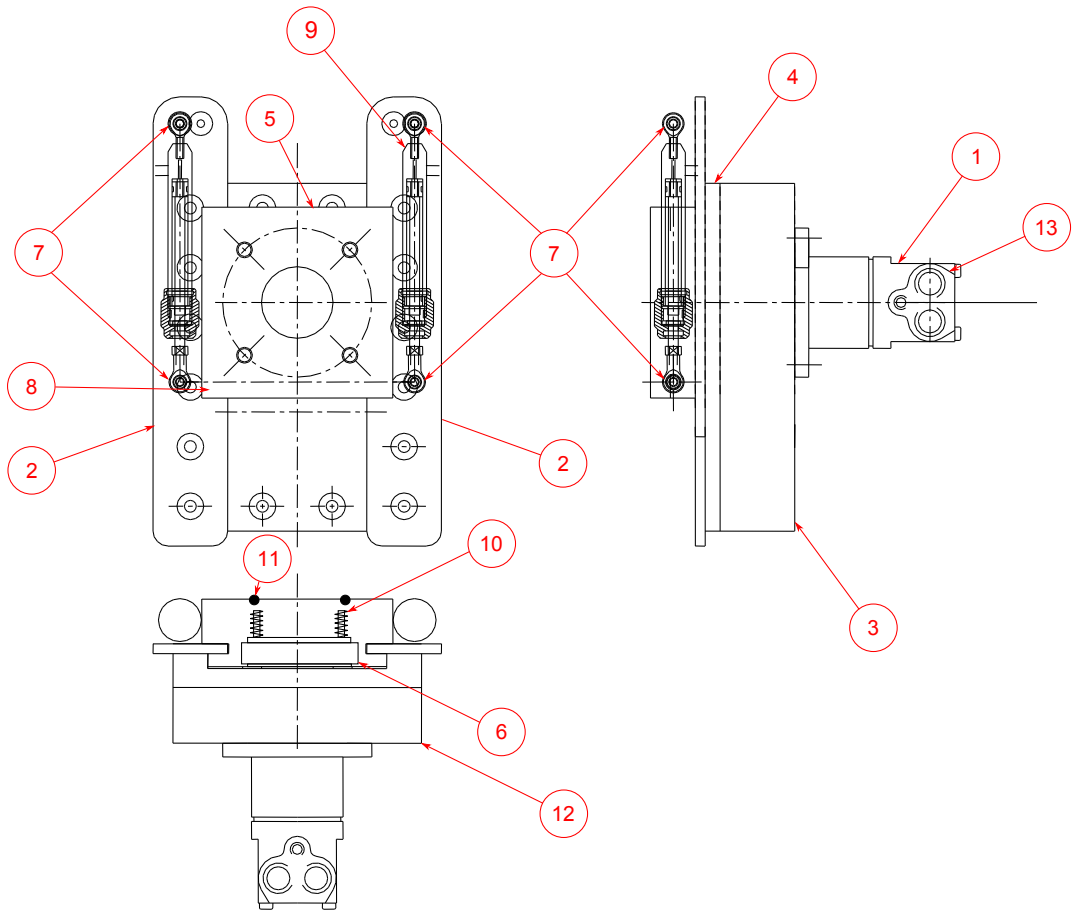

Figure 5.1. AnchorZip10 Parts Diagram

Table 5.1. Parts List

Item	QTY	Part Number	Old Part Number	Description
1	1	S10523	TI-F11-10-99098P	Speedi Sleeved F11-10 Motor
2	2	S10500	TI-AZ10-002B	Slide Bar
3	1	S10502	TI-AZ10-003B	Main Case
4	1	S10503	TI-AZ10-004A	Case Top
5	1	S10501	TI-AZ10-003-03B	Interface Block
6	1	S10505	TI-AZ10-006-LP	Valve Ring - Low Pressure
6	1	S10504	TI-AZ10-006-HP	Valve Ring - High Pressure
7	4	S10506	TI-AZ10-007A	Spacer
8	1	S10507	TI-AZ10-008A	Valve Bar
9	2	S10555	TI-10/110-0-RSE-C	110mm Stroke Actuator
10	12	S10518	TI-C04800742250S	Spring, Compression, 12.19mm OD x 57.15mm lg
11	1	S10509	TI-BS622NI70	'O' Ring, NI70, BS622
12	1	S10548	TI-ZJU-8907	Zip 120mm Impeller
	1	S10549	TI-ZJU-8908	ZP Impeller Mount Boss
	1	S10550	TI-ZJU-8909	ZP Impeller Retainer
13	1	S11053	TI-3002-01-000	Volvo Motor Protector Assembly

Table 5.2. Hardware List

QTY	Part Number	Old Part Number	Description
12	S10467	TI-89510-M12-120	Fastener, C/Sink Allen Head, M12 x 120, SS A4 80
4	S10470	TI-89510-M12-90	Fastener, C/Sink Allen Head, M12 x 90, SS A4 70
2	S10469	TI-89510-M12-50	Fastener, C/Sink Allen Head, M12 x 50, SS A4 70
4	S10473	TI-89510-M6-18	Fastener, C/Sink Allen Head, M6 x 18, SS A4 80
18	S10487	TI-89620-M12	Nyloc Hex Nut, M12, SS A4
18	S10490	TI-89710-M12	Flat Washer, M12, SS A4
1	S10491	TI-89710-M6	Flat Washer, M6, SS A4
2	S10485	TI-89550-M8-50	Fastener, Hex Head, M8 x 50, SS A4 80
2	S10484	TI-89550-M8-40	Fastener, Hex Head, M8 x 40, SS A4 80
2	S10488	TI-89620-M8	Nyloc Hex Nut, M8, SS A4
1	S10480	TI-89530-M6-20	Fastener, Socket Head, M6 x 20, SS A4 80

Reverse Valve Actuators

The reverse valve actuators are retained by set screws through the spherical joints at each end of the cylinder. Seal kits are available for the cylinders should replacement become necessary.

Relief Valve Slipper Ring and Setting Relief Pressure

Early models of the AnchorZip10 had a standard interface block allowing suction relief over a pressure range of 0.95 to 4.1 bar configurable by selecting different quantities of weak and strong springs. For pressures above 4.1 bar a modified interface block was required which clamped the relief valve shut and allowed higher pressures to be achieved without relief.

The later versions of the AnchorZip10 removed the need for the modified interface block by introducing a new high pressure valve ring. If this new valve ring is used in conjunction with the existing low pressure valve ring a range of pressure relief from 0.81 and 9.27 bar is achievable. This can be done by simply varying the quantities of the same spring strength. The revised interface block supplied has an o-ring groove so that the higher pressures are easier to achieve.



Note

This manual only details adjustment of the later versions of the AnchorZip10. If in doubt as to which version is to hand, please contact *Tritech International Ltd* Technical Support.

Setting Relief Pressure

The relief interface block (item 5 on Figure 5.1, “AnchorZip10 Parts Diagram”) containing the valve ring is held in place by the slide bars mounted to the pump body and the hydraulic actuators. It may be removed by undoing the bolts securing the actuator spherical joints to the valve bar (item 8 on Figure 5.1, “AnchorZip10 Parts Diagram”), leaving the interface block free to slide along the slide bars to the edge of the pump body. Due to the spring tension it will be quite stiff to move and can be edged along by tapping the interface block with a soft faced hammer.



Warning

The assembly is spring loaded. Great care must be exercised not to remove this item without first clamping the ring to the interface body.

Once the interface block has reached the edge of the main block it should be very carefully knocked until the valve ring (item 6 on Figure 5.1, “AnchorZip10 Parts Diagram”) is visible by about 12mm. A G clamp should then be fastened around the block and exposed parts of the valve ring.

The interface block can then be moved again very carefully until 60% of the valve ring is exposed. Two further G clamps should then be applied across the diameter of the valve ring. The unit can then be fully removed and the G clamps carefully released to de-energise the springs.



Figure 5.2. LP Valve Ring



Figure 5.3. HP Valve Ring

Springs	bar	psi	Springs	bar	psi
3	0.81	12	3	2.32	34
4	1.08	16	4	3.09	45
6	1.62	23	6	4.64	67
8	2.16	31	8	6.18	90
9	2.43	35	9	6.95	101
10	2.7	39	10	7.73	112
12	3.24	47	12	9.27	134

**Note**

Springs must always be fitted in a symmetrical pattern.

Use spring: S10518

The Interface Block

Lightly grease the S10509 (TI-BS622NI70) o-ring and place it in the valve ring o-ring groove.



Figure 5.4. Valve Ring

On the interface block place the correct quantity of S10518 springs symmetrically in the holes provided.



Figure 5.5. Springs in Place

Place the valve ring over the springs and tighten using G clamps

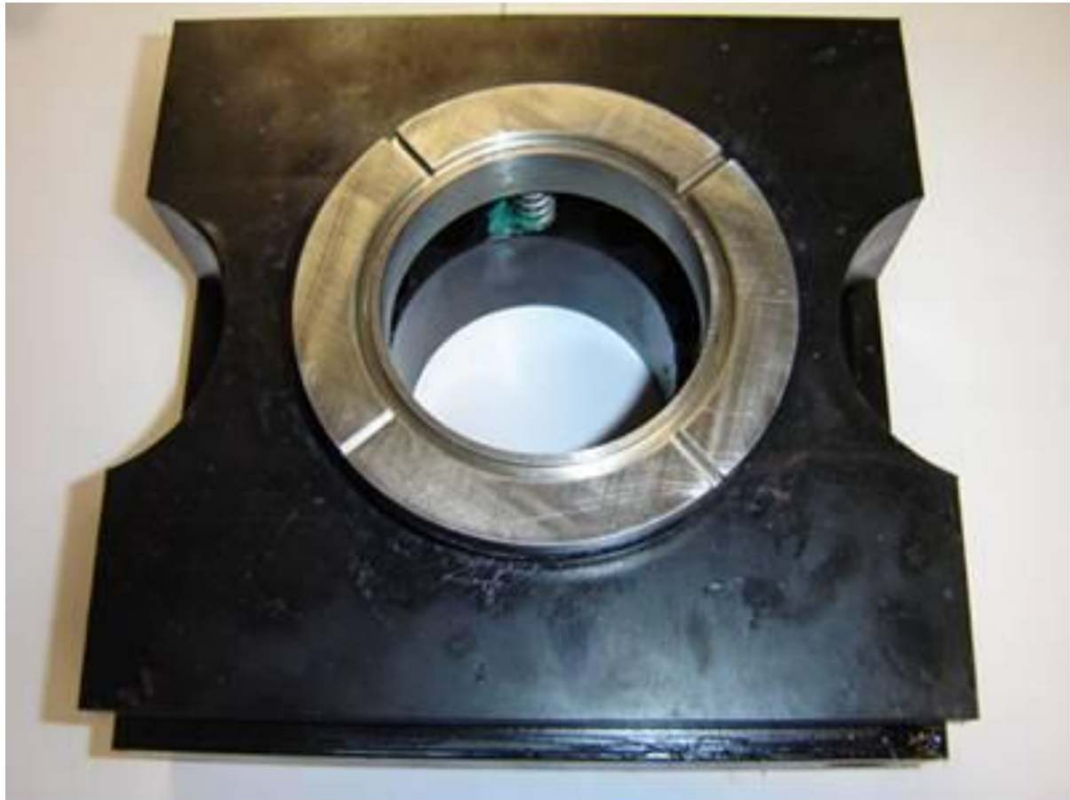

Figure 5.6. Valve Ring in Place

Compress the valve ring until flush with the block face and mount the interface block on the AnchorZip10. Carefully remove the G clamps and the block slides into position. To move the block to its final position, tap the block with a soft faced hammer. Once the block is in position attach the actuators.



Figure 5.7. Actuators Re-attached

Finally apply an anti-seize compound to the M16 threaded inserts to aid lubrication when fitting the mating connection and grease/fit the BS156 (S10508) o-ring to the interface block if required.

Hydraulic Motor and Impeller

In order to remove the motor and impeller it is necessary to completely disassemble the pump.

First remove the actuator cylinders and interface block, remove all the bolts holding the guide bars and case parts together and then split the case. The impeller can then be removed from the pump shaft by undoing the set screw at the centre of the impeller boss, undoing the bolts securing the Volvo motor, and easing the motor away from the top case which will in turn pull off the impeller.

When reassembling apply some anti-seize grease to the motor shaft before fitting the impeller. Press the impeller boss onto the shaft right up to the shoulder. Assemble the retainer onto the shaft end and secure the setscrew using a small quantity of Loctite. If the impeller has been removed from its mounting boss, replace the impeller on the boss and secure the four countersunk screws with Loctite.

6. Troubleshooting

If the pump is experiencing poor performance check the following:

- Check that there is no sign of any suction hose in use collapsing under suction.
- Check the operation of the reversing system for full stroke.
- Check that the hydraulic motor runs freely without excessive noise or vibration.
- Check that the hydraulic flow meets the specification.

Appendix A. Motor Protector Assembly Procedure

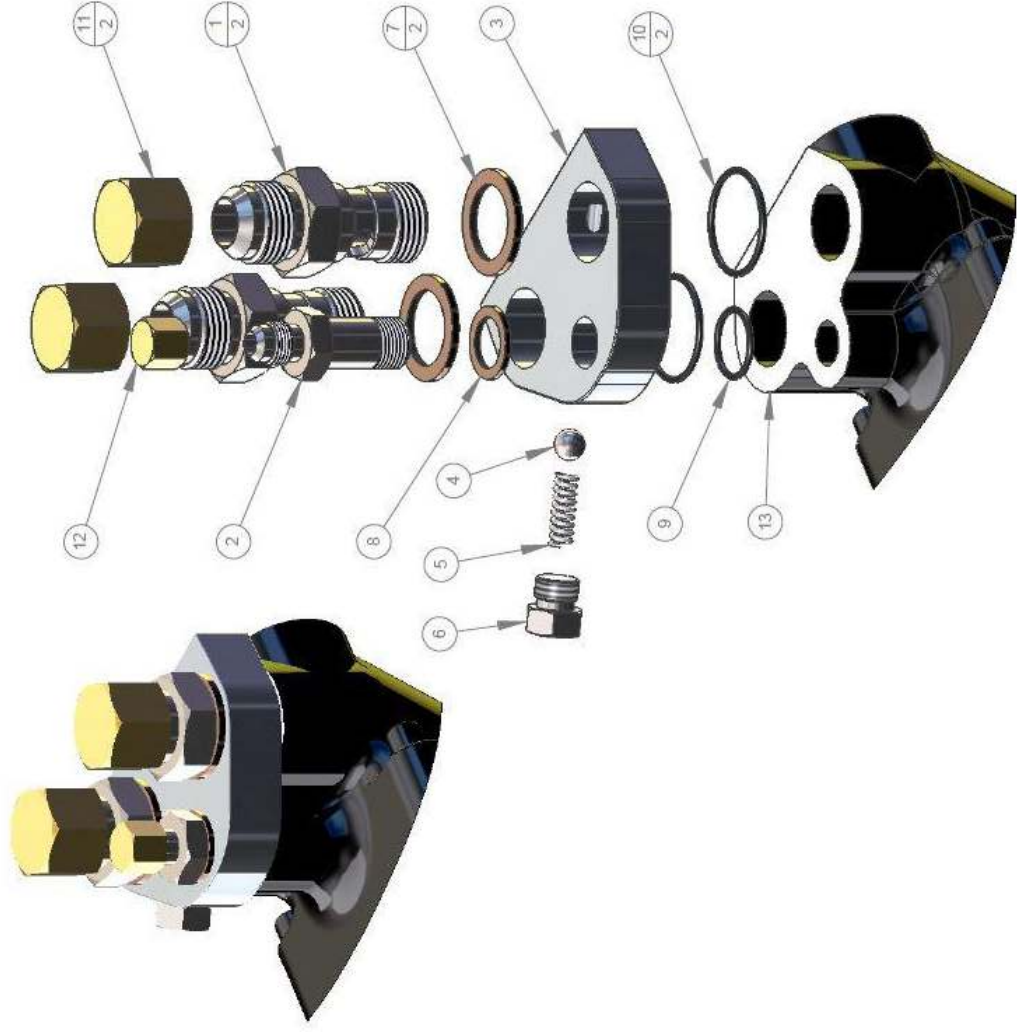

Assembly Instruction

Remove any existing port fittings from the F11-10 Volvo motor. Ensure that the top face of the motor is free from any debris such as paint, dirt or grit. Clean and degrease the surface.

1. Place the 10 mm High Carbon chrome Alloy Ball Bearing [4] into the Valve Block F11-10 [3] and seat in place.
2. Apply a small amount of anti-galling compound to the thread and a small amount of Molykote 111 silicon grease to the O-rings on the Plug Hex Head [6].
3. Place the Compression Spring [5] into the Valve Block F11-10 8 and secure in place by tightening down the Plug Hex Head [6].
4. Place a SEAL Dowty 3/4" Self Centre S/S Ring [7] on each 3/4- 14 BSP - JIC 12 Connector [1].
5. Place a SEAL Dowty 3/8" Self Centre S/S Ring [8] on the 3/8-19 BSP JIC 6 Connector [2].
6. Place the assembled components from instruction 4 & 5 into the top of Valve Block F11-10 [3].
7. Grease with Molykote 111 and place an O-ring 32 x 2 [10] into each groove on the Valve Block F11-10 [3] Base.
8. Grease with Molykote 111 and place an O-ring 20 x 2 [9] into the groove on the Valve Block F11-10 [3] Base.
9. Apply a small amount of anti-galling compound to the threads of the BSP Connectors [1] & [2]

10 Mount the assembled components from instruction 8 onto the F11-10 Volvo Motor [13] and tighten down using an adjustable spanner.

11 Place the Cap, Female No 12 JIC Carbon Steel [11] & Cap, Female No 6 JIC Carbon Steel [12] onto the BSP Connectors [1] & [2] and hand tighten

Item	New Part Number	Old Part Number	Description	QTY
1	S10446	TI-3002-01-002	Motor Protector Connector, 3/4-14 BSP	2
2	S10447	TI-3002-02-003	Motor Protector Connector, 3/8-19 BSP	1
3	S10445	TI-3002-01-001	Motor Protector Valve Block, F11-10	1
4	S10497	TI-90100-10	Ball Bearing, 10mm High Carbon Chrome	1
5	S10522	TI-D21770	Spring, Compression	1
6	S10461	TI-89401	Plug, Hex Head, 6P50NSS, 316 S/S	1
7	S10459	TI-89301	Seal, Dowty, 3/4, Self-Centre, S/S Ring	2
8	S10458	TI-89300	Seal, Dowty, 3/8, Self-Centre, S/S Ring	1
9	S10511	TI-BSI0200-20NI70	O-Ring 20 x 2	1
10	S10513	TI-BSI0320-20NI70	O-Ring 32 x 2	2
11	S10457	TI-89202	Cap, Female JIC12 Carbon Steel	2
12	S10456	TI-89201	Cap, Female JIC6 Carbon Steel	1
13	S10523	TI-F11-F10-99098P	Painted F11-10 Motor	1

Appendix B. Performance Curves

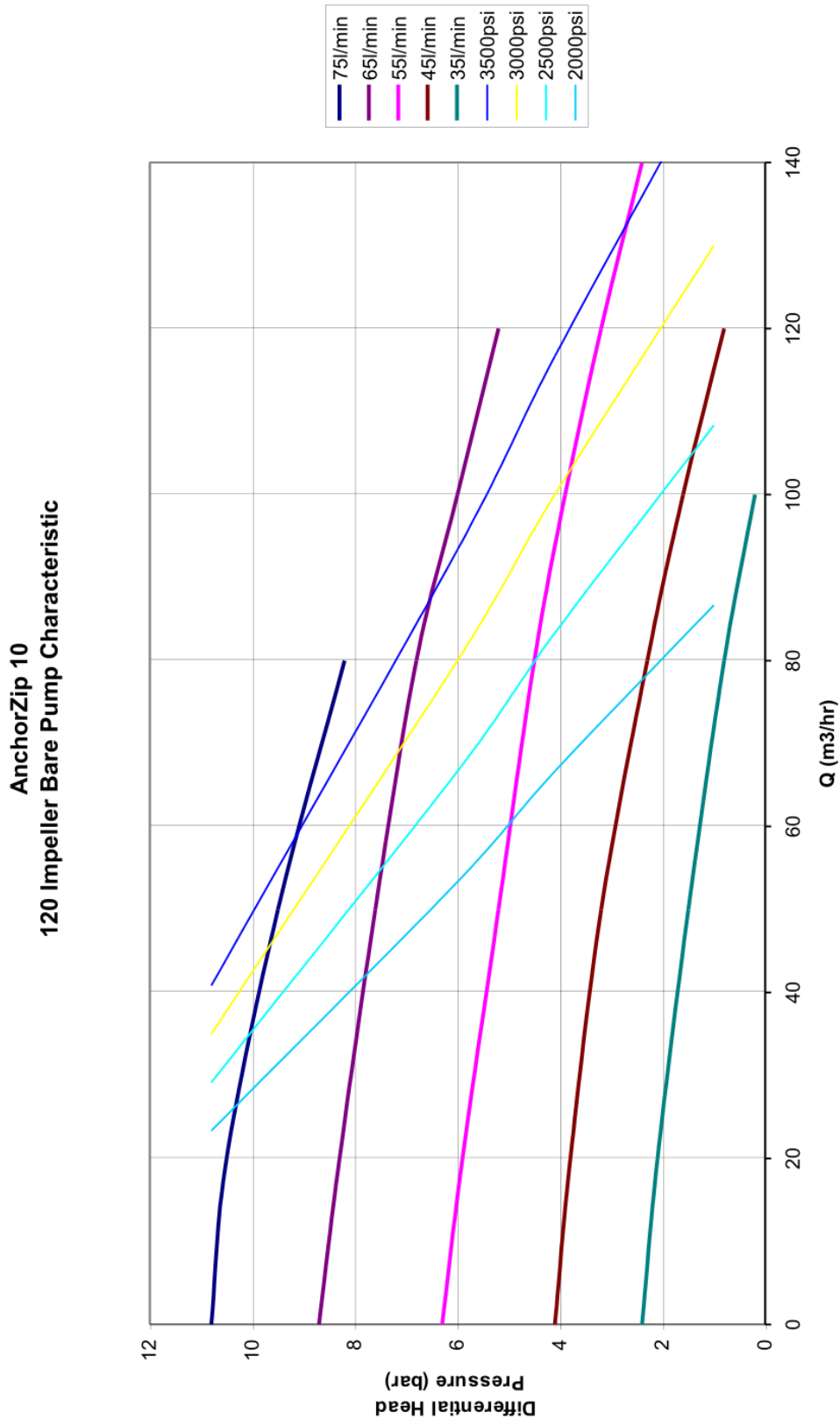

Figure B.1. Performance Curves