

Merlin

Product Manual

0711-SOM-00001, Issue: 02



© Trittech International Ltd

The copyright in this document is the property of Trittech International Ltd. The document is supplied by Trittech International Ltd on the understanding that it may not be copied, used, or disclosed to others except as authorised in writing by Trittech International Ltd.

Trittech International Ltd reserves the right to change, modify and update designs and specifications as part of their ongoing product development programme.

All product names are trademarks of their respective companies.

Table of Contents

Help & Support	4
Warning Symbols	5
1. Introduction	6
2. Specification	7
3. Installation	8
3.1. Mechanical	8
3.2. Water Hoses	8
3.3. Hydraulics	10
3.4. Retro Flush Valve and Jet Bypass Valve	12
3.5. Seal Compensator	12
4. Principles of Operation	14
4.1. Suction Operation	14
4.2. Jetting Operation	14
5. Maintenance	16
5.1. Basic Procedures	16
5.2. Tools Required	17
6. Troubleshooting	18
A. Motor Protector Assembly Procedure	19
B. Merlin Assembly	21

Help & Support

First please read this manual thoroughly (particularly the Troubleshooting section, if present). If a warranty is applicable, further details can be found in a Warranty Statement at the end of the manual.

Tritech International Ltd can be contacted as follows:

	Mail	<i>Tritech International Ltd</i> Peregrine Road Westhill Business Park Westhill, Aberdeenshire AB32 6JL, UK
	Telephone	++44(0)1224 744 111
	Fax	++44(0)1224 741 771
	Email	support@tritech.co.uk
	Website	www.tritech.co.uk

Prior to contacting *Tritech International Ltd* please ensure that the following is available:

1. The Serial Numbers of the product and any *Tritech International Ltd* equipment connected directly or indirectly to it.
2. Software or firmware revision numbers.
3. A clear fault description.
4. Details of any remedial action implemented.



Contamination

If the product has been used in a contaminated or hazardous environment you *must* de-contaminate the product and report any hazards *prior* to returning the unit for repair. *Under no circumstances should a product be returned that is contaminated with radioactive material.*

The name of the organisation which purchased the system is held on record at *Tritech International Ltd* and details of new software or hardware packages will be announced at regular intervals. This manual may not detail every aspect of operation and for the latest revision of the manual please refer to www.tritech.co.uk

Tritech International Ltd can only undertake to provide software support of systems loaded with the software in accordance with the instructions given in this manual. It is the customer's responsibility to ensure the compatibility of any other package they choose to use.

Warning Symbols

Throughout this manual the following symbols may be used where applicable to denote any particular hazards or areas which should be given special attention:



Note

This symbol highlights anything which would be of particular interest to the reader or provides extra information outside of the current topic.



Important

When this is shown there is potential to cause harm to the device due to static discharge. The components should not be handled without appropriate protection to prevent such a discharge occurring.



Caution

This highlights areas where extra care is needed to ensure that certain delicate components are not damaged.



Warning

DANGER OF INJURY TO SELF OR OTHERS

Where this symbol is present there is a serious risk of injury or loss of life. Care should be taken to follow the instructions correctly and also conduct a separate Risk Assessment prior to commencing work.

1. Introduction

The Merlin is an integrated eductor based excavation system which is designed to pump mud, sand, gravel, drill cuttings or shale without risk of blockage.

A heavy-duty cylinder operates a valve to reverse the flow at the nozzle to eject any object which may be causing an obstruction. A second cylinder operates a bypass valve to provide a powerful direct jet to break up heavy and cohesive seabed mud and sand prior to excavation.

The pump may be configured to an intermediate position allowing combined use of suction and jettings. Both the impeller and eductor have been optimised for use on Work-class ROVs.

2. Specification

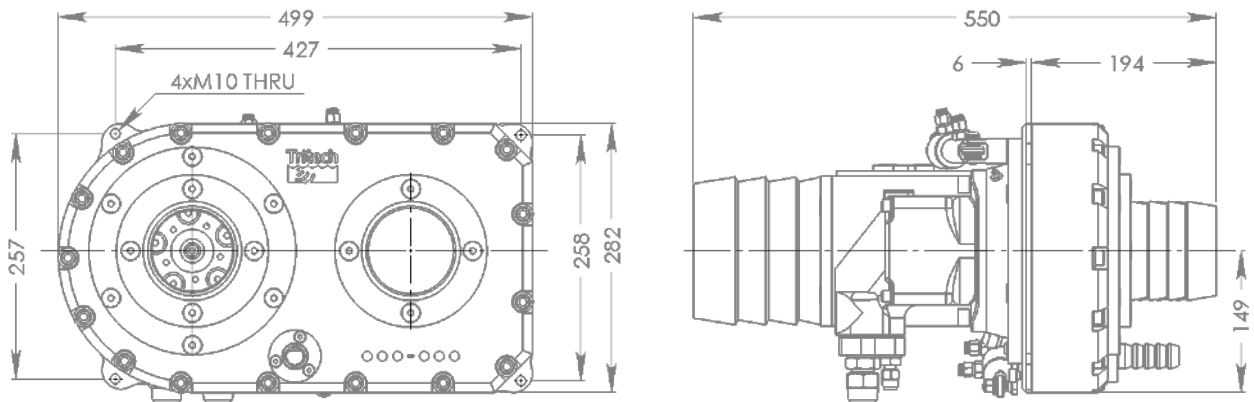

Not to scale, dimensions in mm.



Warning

Never use the same size fitting for pressure hoses and the case drain. If this is done there is significant risk of incorrect hook-up which will lead to pressure being applied to the motor casing and could result in an explosion and personal injury.

Hydraulic Motor Input	
Pressure	170 to 250 Bar (2450 to 3600 psi)
Flow	65 to 110 litres/min (17 to 29 USgpm)

Hydraulic Fittings	
Motor A & B	No. 12 JIC male
Motor case drain	No. 6 JIC male
Actuator Connection	No. 4 JIC male

Actuator	
Min. pressure	120 Bar (1740 psi)
Max. pressure	240 Bar (3480 psi)

Check Valve	
Norm.	Tritech Volvo Protector Assembly
Alt.	Integrated Hydraulics FPR-1/22-0.5 (cracking pressure 0.5 bar)

Output	
Typical output jetting	Up to 600 litres/min @ 8 Bar (160 USgpm @ 115 psi)
Typical output suction	2000 - 4000 litres/min (500 - 1000 USgpm)
Typical solids removal	10 - 40 tonnes/hour (350 - 1500 lb/min)

Nozzle Dimensions	
Jetting	25.4mm (1")
Discharge	155mm (6")
Suction	104mm (4")
Clean water inlet	104mm (4")

Weight and Materials	
Weight in air	40kg (90lb)
Weight in water	17kg (38lb)
Materials	Stainless steel, Nylacast, UHMWPE

3. Installation



Warning

Do not power the Merlin pump or hydraulic valve actuators until all hoses are properly connected.

If powering or testing on deck it is important to ensure that all appropriate safety measures are in place to prevent injury.

3.1. Mechanical

The pump may be mounted in any orientation on the vehicle. There are four mounting points with 10mm clearance through holes

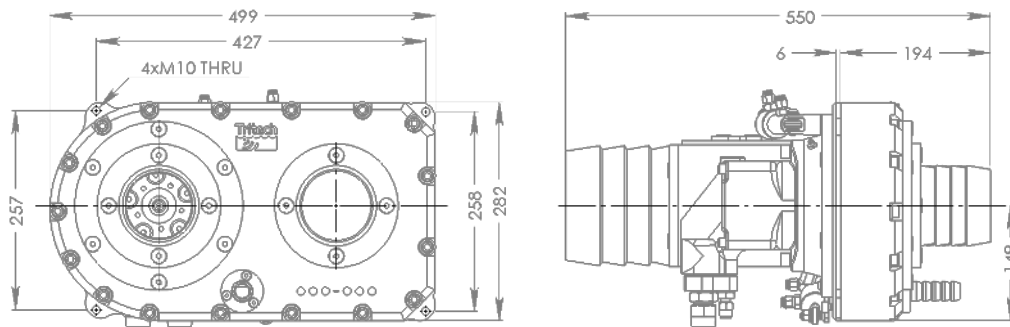

Not to scale, dimensions in mm.

the pump should not be mounted using the motor or hose nozzles as attachment points. Case bolts should not be used.

3.2. Water Hoses

Hose Types

For correct hose sizes refer to Chapter 2, *Specification*.

The recommended hose type is: **heavy duty nylon spiral reinforced**.

This hose type is usually semi-transparent which assists visual inspection for damage and blockages. Since it is all plastic it is light in water.

Both suction and discharge hoses should have a smooth internal bore with spiral reinforcement.

Layflat style hoses are not recommended for discharge.

Fittings

Use standard heavy-duty worm drive clips. Use of heavy-duty two bolt clamps will result in damage to the hose connections on the pump unit.

Clean Suction Intake Screen

It is recommended that a *Tritech International Ltd* supplied suction strainer is used with the pump. If using another strainer it must meet the following specifications:

- Maximum hole size: square mesh of 4mm aperture or circular perforations of 6mm diameter.
- Minimum total free flow area: 0.025m²

The pump should not be operated in any circumstances without a suction screen.

Dredge Suction Nozzle

Suction nozzles should be designed with a nozzle cross-section area of approximately 80000mm²

Smaller nozzles may be used but material removal rates will be reduced. Larger nozzles are of no benefit and will reduce performance.

A nozzle guard should be fitted that will pass a maximum of a 60mm diameter sphere or 50mm sided cube. The pump can pass single objects of a larger size, but if it takes in a stream of objects then blockages can occur.

Jet Nozzle

The recommended sizes are 12 to 18mm diameter or an equivalent area.

The optimum size will need to be determined by trial because the water output from the power pump will vary depending on the oil pressure and flow available from the ROV hydraulic system.

3.3. Hydraulics

Oil

The pump should be operated using a premium grade mineral based hydraulic oil of ISO VG 22 to 23

Filtration

The hydraulic system filtration must be to a minimum of 10µm absolute standard. A 10µm nominal standard is regarded as inadequate.

The recommended filtration is UN elements produced by Pall Industrial Hydraulics Ltd. or equivalent products.

Hook-up

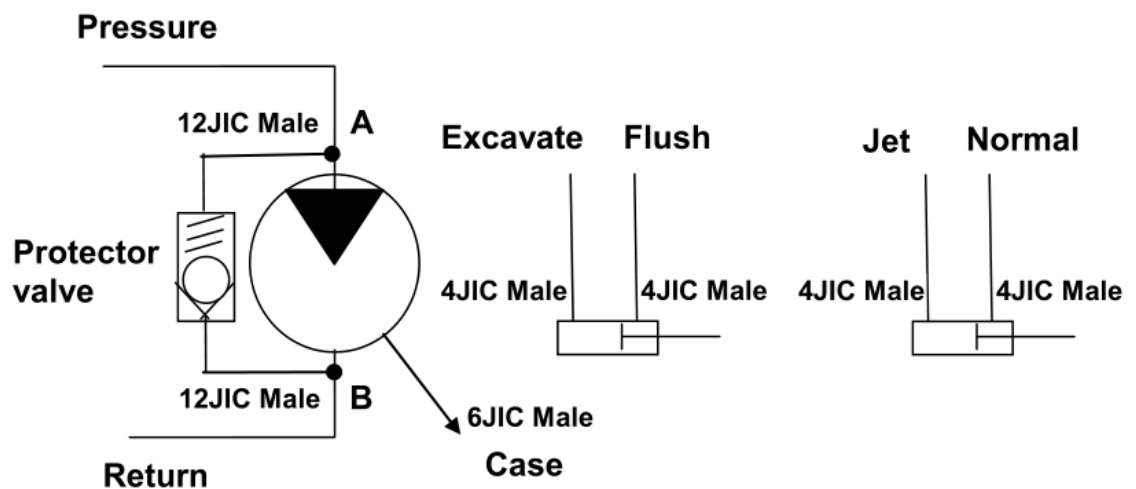

Figure 3.1. Hydraulic Hook-up Orientation

The pump is configured for correct rotation when the hydraulic supply is connected to the "A" port of the Volvo motor and the return line to the "B" port.

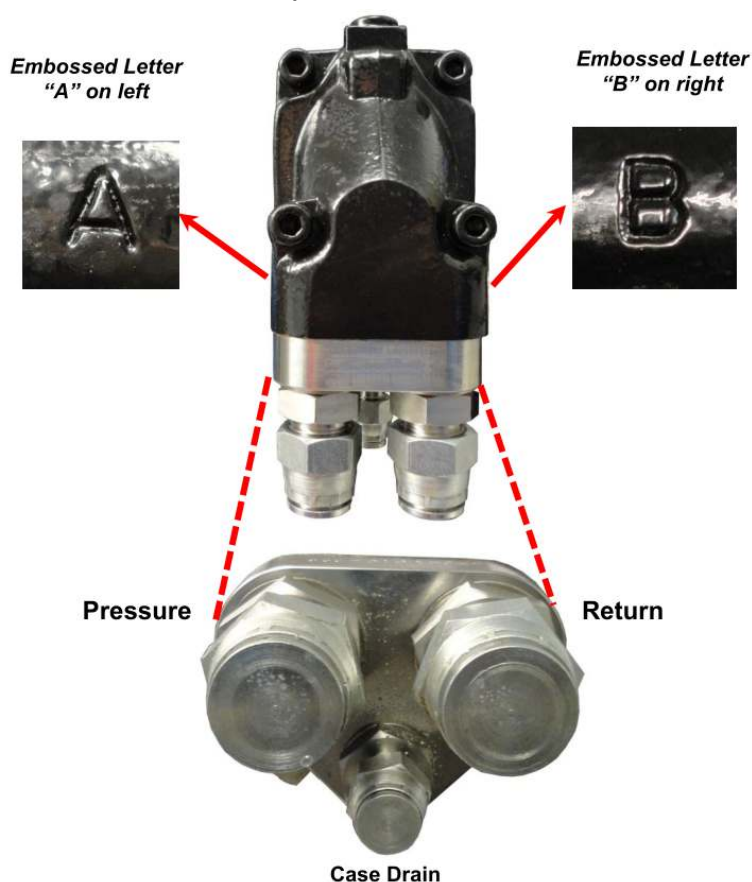

Figure 3.2. Motor viewed when fitted to Merlin with hydraulic fittings downwards

The drain connection from the motor back to the tank is required to be a minimum of $\frac{3}{8}$ inch bore. The drain line should return straight to the tank without restriction. It is possible to connect the drain line back to a larger bore drain manifold, which has been correctly sized to accommodate all drains attached to it.



Warning

The drain line should not be connected to any return flow lines.



Warning

Self-sealing quick disconnect connectors should not be used on the drain line. Such connectors, if incorrectly fitted, may result in pressurisation of the motor casing which could fail explosively under pressure resulting in significant risk of personal injury.

Required Hydraulic Flow

For the Volvo F11-19 motor the vehicle hydraulic system should be capable of supplying a flow rates and pressure detailed in Chapter 2, *Specification*.

Achieving the required flow in an unloaded condition is no guarantee that the supply can actually be met in working conditions.

It is recommended that the installation be checked using a hydraulic flow meter equipped with a loading valve which can simulate the motor running under load.

In order to avoid pressure losses a minimum of ½ inch bore pipes or hoses are used on the flow and return lines (¾ inch or larger is recommended).



Warning

Under no circumstances should the flow be allowed to exceed the 25 litres per minute (while testing in air).

Exceeding this pressure when operating in air (when there is no back-pressure on the pump) may cause a catastrophic failure of the pump and result in personal injury.

3.4. Retro Flush Valve and Jet Bypass Valve

To independent controls are required, one for the jetting actuator and one for the retro valve.

The actuators can be connected to any standard three-position 4-way solenoid valve. Pilot operated check valves is preferred but a closed centre spool valve is adequate. If either actuator is not used then they must be filled with oil and securely capped. This is particularly important for the jet bypass valve, which could easily be pulled open severely reducing efficiency.

The supply pressure for reliable operation is 120 bar.

The actuator connection fittings are: No. 4 JIC male

The jet valve should be powered shut when jetting is not required.

3.5. Seal Compensator

The Merlin has a separately compensated seal void which is grease filled and has its own miniature compensator.

On installation the compensator level should be checked. The stem has an indicator groove showing when it is full. If necessary gently apply grease via the grease nipple provided until the groove just shows or the grease is expelled from the overflow.



Caution

Pump the grease very slowly to avoid building up excessive pressure in front of the motor face.

4. Principles of Operation

4.1. Suction Operation

The Merlin pump is based on the principles of the annular eductor pump. It has a monoblock configuration in which the eductor pump and power pump are contained within a common body.

The power for the eductor section of the pump is provided by a stream of clean water driven by the centrifugal impeller section.

Clean water is drawn into the inlet, passes through the impeller of the power pump and is then injected into the main suction stream via the annular eductor nozzle.

The main suction stream can convey heavy contamination of sand, mud, gravel and drilling debris.

The pump has a retro flush valve just behind the eductor. When this is closed (operating cylinder extended) the power fluid is then directed to the suction nozzle. This feature can be used to clear a blocked suction nozzle or to complete a deburial operation by removing the sand and mud from around an object.

The optimum performance will be obtained with the nozzle pushed deep into the debris and agitated gently. Where a great deal of debris is encountered it will be necessary to keep withdrawing the nozzle.

4.2. Jetting Operation

The body of the pump contains a jetting valve. The purpose of the valve is to provide water to the jetting outlet. The valve may be configured to maintain suction during jetting operations. For normal dredging operations the jet valve should be kept shut.



Note

The Merlin can be setup to restrict flow through the jetting valve. To implement this place the M8 x 16 SKT CAP (item 9) in one of the three holes in the housing mounting plate (item 1 - see Appendix B, *Merlin Assembly*).

- Hole 1 gives : 'low jetting, high flow'
- Hole 2 gives : 'medium jetting, medium flow'

- Hole 3 gives : 'high jetting, low flow'

5. Maintenance



Warning

Do not power the pump or hydraulic valve actuators until all hoses are properly connected to the pump.

There is a serious risk of injury to fingers if inserted into either the power water intake or the pump delivery port.

If undertaking any testing operations suitable guards and other safety measures must be in place.

5.1. Basic Procedures

Hydraulic Motor Shaft Seals

The pumps are fitted with either an 'H' (red) or 'V' (brown) type seal. The type V is the standard seal and is high pressure, high temperature.

Replacement of seals with anything other than a genuine seal (or *Tritech International Ltd* supplied seal) will invalidate the warranty.

Pre-dive

Visual check for external damage.

Check hoses are secure.

Check mountings are secure.

Check clean water suction strainer is in place and clear.

Check the mini compensator for the seal housing is extended. If not apply one or two strokes with a grease gun until the compensator relieves.

Storage



Note

If the vehicle will be inactive for more than 48 hours run a fresh water hose into the clean water suction strainer for a few minutes and then spin the hydraulic motor for about 15 seconds (taking care not to over-speed).

If the pump is removed from the vehicle, then the hydraulic ports should be blanked off with metal caps and the unit washed out with fresh water.

Leave the actuator valves in their retracted position.

Visually inspect the leading edges of the power pump impeller for damage and erosion.

Up to four blades may have leading edge damage of 5mm width and 4mm depth before replacement becomes essential.

If the majority of leading edges are eroded more than 3.5mm back from the bore of the inlet nozzle then consideration should be given to replacing the impeller.

5.2. Tools Required

The following tools are required to work on the pump:

- 22mm open ended spanner
- 13mm open ended spanner
- 10mm Allen key
- 8mm Allen key
- 6mm Allen key
- 5mm Allen key
- 2.5mm Allen key
- Dead blow hammer
- Loctite - "Studlock" for reassembly

For detailed assembly procedures refer to Appendix B, *Merlin Assembly*.

6. Troubleshooting

If the Merlin is experiencing poor performance check the following:

- Check that the clean water suction strainer is clear and that there are no blockages in the hose.
- Check that the retro-flush valve is opening fully.
- Check that the jet valve is seating properly.
- Check that the suction hose reinforcement is intact and that there is no sign of the hose collapsing under suction.
- Check that the discharge hose is not damaged or kinked.
- Remove the clean water suction hose from the pump and check that the face of the impeller is not obstructed by material like rope fibre or shreds of plastic.
- Check that the hydraulic motor runs freely without excessive noise or vibration.
- Check that the hydraulic flow meets specification.

Appendix A. Motor Protector Assembly Procedure

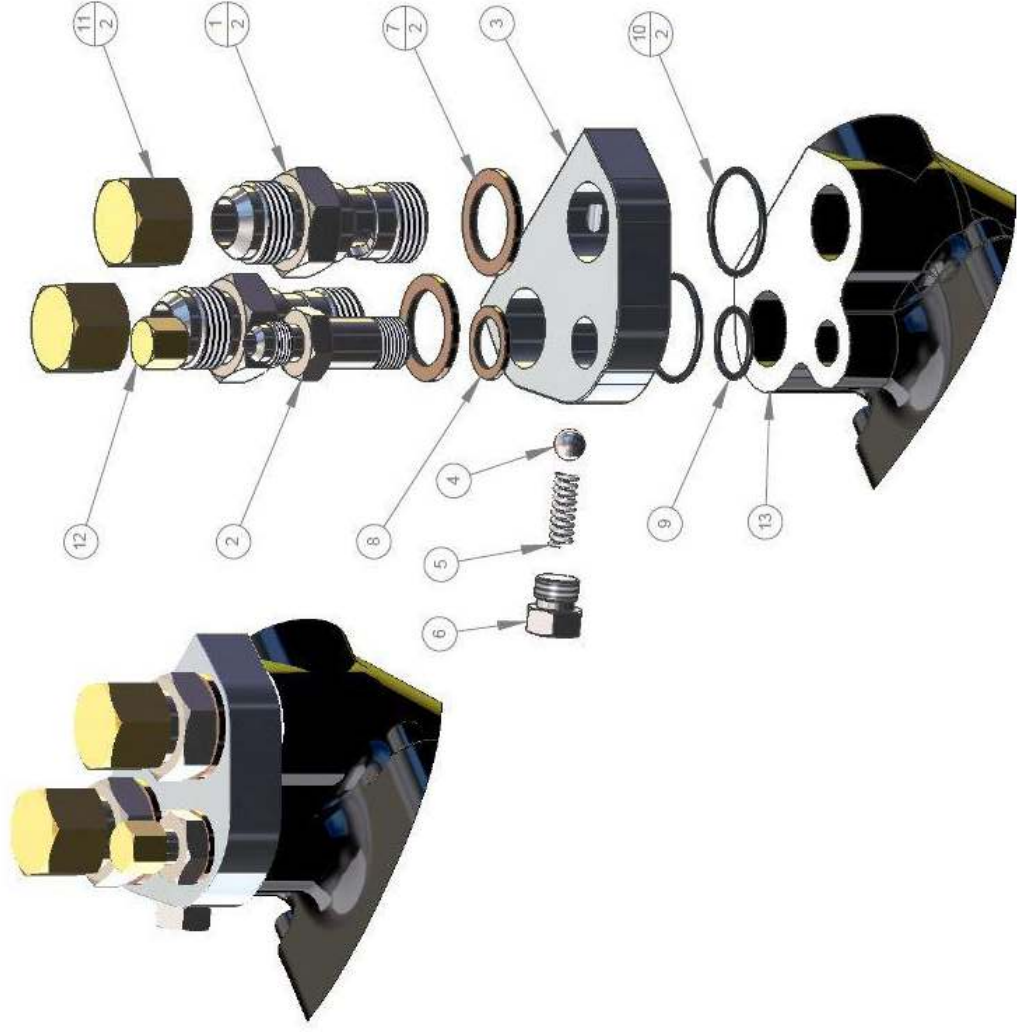

Assembly Instruction

Remove any existing port fittings from the F11-19 Volvo motor. Ensure that the top face of the motor is free from any debris such as paint, dirt or grit. Clean and degrease the surface.

1. Place the 10 mm High Carbon chrome Alloy Ball Bearing [4] into the Valve Block F11-19 [3] and seat in place.
2. Apply a small amount of anti-galling compound to the thread and a small amount of Molykote 111 silicon grease to the O-rings on the Plug Hex Head [6].
3. Place the Compression Spring [5] into the Valve Block F11-19 8 and secure in place by tightening down the Plug Hex Head [6].
4. Place a SEAL Dowty 3/4" Self Centre S/S Ring [7] on each 3/4- 14 BSP - JIC 12 Connector [1].
5. Place a SEAL Dowty 3/8" Self Centre S/S Ring [8] on the 3/8-19 BSP JIC 6 Connector [2].
6. Place the assembled components from instruction 4 & 5 into the top of Valve Block F11-19 [3].
7. Grease with Molykote 111 and place an O-ring 32 x 2 [10] into each groove on the Valve Block F11-19 [3] Base.
8. Grease with Molykote 111 and place an O-ring 20 x 2 [9] into the groove on the Valve Block F11-19 [3] Base.
9. Apply a small amount of anti-galling compound to the threads of the BSP Connectors [1] & [2]

10 Mount the assembled components from instruction 8 onto the F11-19 Volvo Motor [13] and tighten down using an adjustable spanner.

11 Place the Cap, Female No 12 JIC Carbon Steel [11] & Cap, Female No 6 JIC Carbon Steel [12] onto the BSP Connectors [1] & [2] and hand tighten

Item	New Part Number	Old Part Number	Description	QTY
1	S10446	TI-3002-01-002	Motor Protector Connector, 3/4-14 BSP	2
2	S10447	TI-3002-02-003	Motor Protector Connector, 3/8-19 BSP	1
3	S10448	TI-3003-00-001	Motor Protector Valve Block, F11-19	1
4	S10497	TI-90100-10	Ball Bearing, 10mm High Carbon Chrome	1
5	S10522	TI-D21770	Spring, Compression	1
6	S10461	TI-89401	Plug, Hex Head, 6P50NSS, 316 S/S	1
7	S10459	TI-89301	Seal, Dowty, 3/4, Self-Centre, S/S Ring	2
8	S10458	TI-89300	Seal, Dowty, 3/8, Self-Centre, S/S Ring	1
9	S10511	TI-BSI0200-20NI70	O-Ring 20 x 2	1
10	S10513	TI-BSI0320-20NI70	O-Ring 32 x 2	2
11	S10457	TI-89202	Cap, Female JIC12 Carbon Steel	2
12	S10456	TI-89201	Cap, Female JIC6 Carbon Steel	1
13	S10551	TI-ZT-F11-19P	Painted F11-19 Motor	1

Appendix B. Merlin Assembly

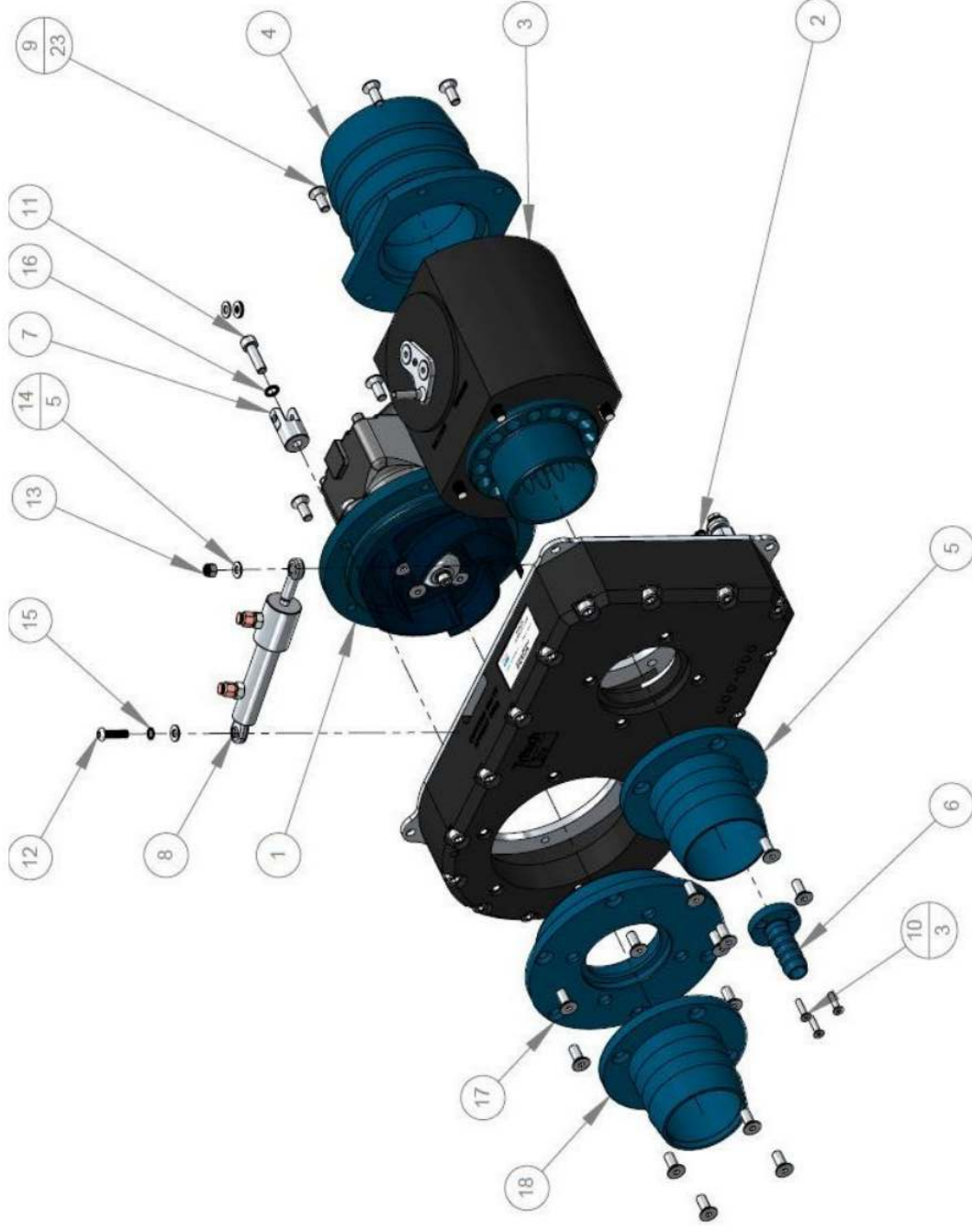

Figure B.1. Main Pump

Main Pump Assembly Instruction

1. Mount the Motor Mount Assembly [1] onto the Body Case Assembly [2] and fasten using 5 x M10 x 25 CSK SKT [9], secure with medium strength Loctite 240 around the counter sink.
NB orientate as shown unless otherwise specified.
2. Fasten the Actuator Swivel Nut [7] to the motor mount plate with a M10 Spring washer [16] and M10 x 75 SKT CAP [11].
3. Mount the Diffuser Assembly [3] onto the Body Case Assembly [2] and fasten using 4 x M10 x 200 SKT CAP Bolts (shown in Diffuser Assembly drawing), secure with medium strength Loctite 240.
4. Mount the Exhaust Nozzle [4] onto the Diffuser Assembly [3] and fasten using 5 x M10 x 25 CSK SKT [10], secure with medium strength Loctite 240 around the counter sink.
5. Place 2 x M8 washer [14] into the gap on the Actuator Swivel Nut [7]. Place the Body end of the ACTUATOR [8] on top of the washers and place a further M8 washer [14] on top of that, fasten with M8 x 30 SKT PAN [12] and M8 Spring washer [15]
6. Secure the Piston of the ACTUATOR [8] to the Diffuser Assembly [3] and fasten with an M8 Nyloc Nut [13] and M8 washer [14]. Ensure the reverse flush valve can rotate back and forth a full 90 and aligns with the suction bore.
7. Mount the Suction Inlet Nozzle [5] onto the Body Case Assembly [2] and fasten using 4 x M10 x 25 CSK SKT [10], secure with medium strength Loctite 240 around the counter sink.
8. Mount the Jetting Nozzle [6] onto the Body Case Assembly [2] and fasten using 3 x M6 x 25 CSK SKT [10], secure with medium strength Loctite 240 around the counter sink.
9. Mount the Volute Impeller Cap [17] onto the Body Case Assembly [2] and fasten using 6 x M10 x 25 CSK SKT [10], secure with medium strength Loctite 240 around the counter sink.
10. Mount the Motive water inlet onto the Volute Impeller Cap [18] and fasten using 4 x M10 x 25 CSK SKT [10], secure with medium strength Loctite 240 around the counter sink.

Item	New Part Number	Old Part Number	Description	QTY
1	N/A	N/A	Merlin Motor Mount Assembly	1
2	N/A	N/A	Merlin Body Assembly	1
3	N/A	N/A	Merlin Diffuser Assembly	1
4	S10536	TI-MSZ-PC013-01	Merlin Exhaust Nozzle	1
5	S10539	TI-MSZ-PC016-01	Merlin Suction Inlet Nozzle	1
6	S10540	TI-MSZ-PC017-01	Merlin Jetting Nozzle	1
7	S10541	TI-MSZ-PC018-01	Merlin Actuator Swivel Nut	1
8	S10557	TI-10/50/RSE-C	50mm Stroke Actuator	1
9	S10464	TI-89510-M10-25	Fastener, C/Sink Allen Head, M10 x 25	23
10	S10474	TI-89510-M6-25	Fastener, C/Sink Allen Head, M6 x 25	3
11	S10476	TI-89530-M10-75	Fastener, Skt Hd Bolt, M10x75	1
12	S10486	TI-89570-M8-30	Fastener, Button Hd Cap, M8x30	1
13	S10488	TI-89620-M8	Nyloc Hex Nut, M8	1
14	S10492	TI-89710-M8	Flat Washer, M8	5
15	S10494	TI-89720-M8	M8 Spring Washer	1
16	S10493	TI-89720-M10	M10 Spring Washer	1
17	S10537	TI-MSZ-PC014-01	Merlin Volute Impeller Cap	1
18	S10538	TI-MSZ-PC015-01	Merlin Motive Water Inlet Nozzle	1

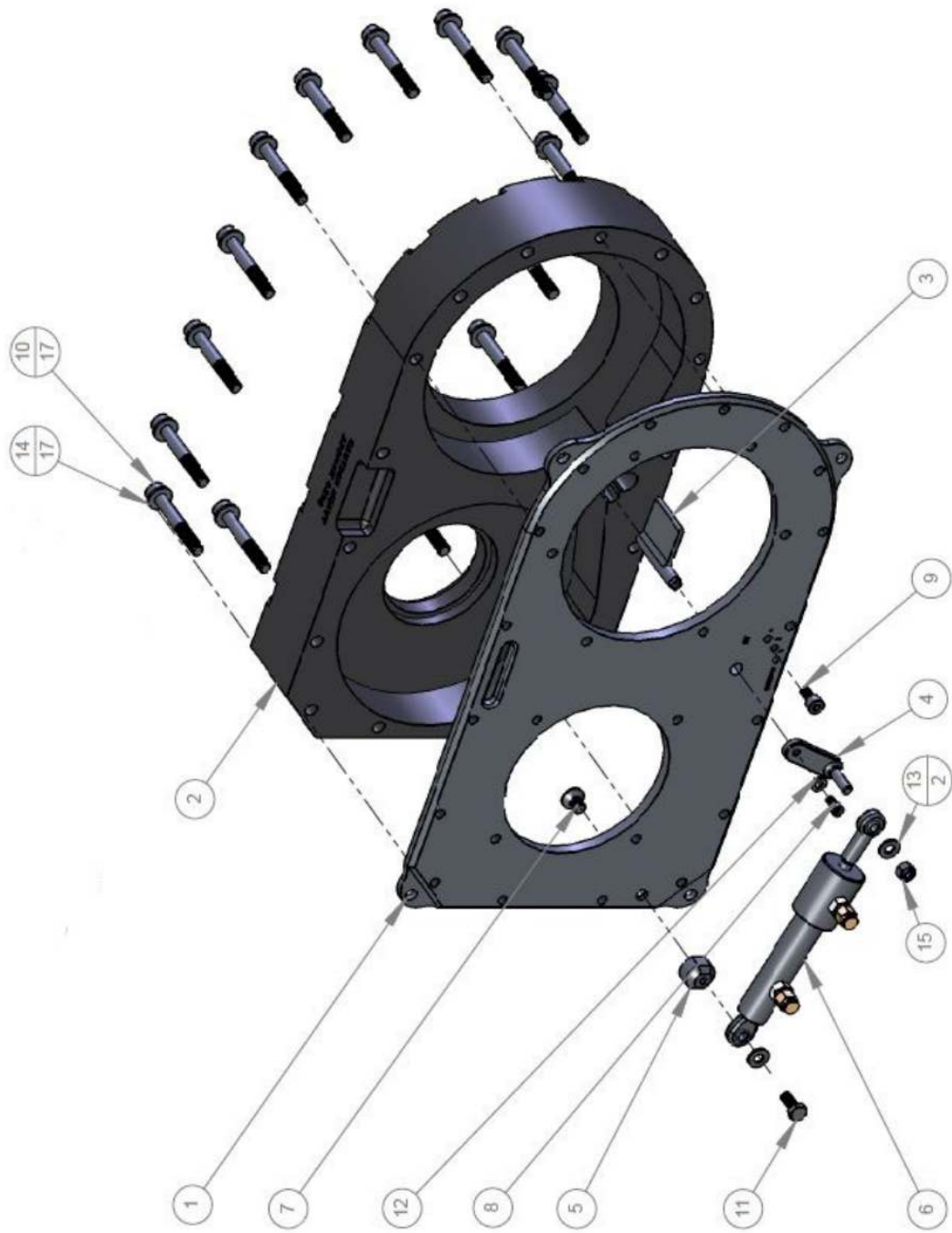

Figure B.2. Merlin Body

Merlin Body Assembly Instruction

1. Place the M10 x 16 SKT CAP [7] screw into the Housing Mounting Plate [1] and secure the Actuator Swivel Mount [5] onto the M10 x 16 SKT CAP [7] with a small amount of medium strength Loctite 240. Arrange the flats on the Actuator Swivel Mount [5] parallel to the case end.
2. Place the Jetting Valve [3] into the Housing Body [2] and place the Housing Mounting Plate [1] onto the Housing Body [2]. Secure in place using 17 x M10 x 75 SKT CAP and washer [10] & [14] & medium strength Loctite 240.
3. Place the Jetting Valve Arm [4] onto the Jetting Valve [3] and secure using 1 x M6 x 12 SKT CAP and Washer [8] & [12] & medium strength Loctite 240.
4. Place the ACTUATOR [6] onto the Actuator Swivel Mount [5] & Jetting Valve Arm [4] respectively and secure in place using M8 x 20 Hex and washer [11] & [13] and M8 Nyloc Nut and Washer [15] & [13]

NB: The unit can be set up to restrict flow through the Jetting Valve. To implement this place the M8 x 16 SKT CAP [9] in one of the three holes in the Housing Mounting Plate [1].

Hole 1 gives; 'Low jetting, High Flow' Hole 2 Gives Medium jetting and Medium flow and hole 3 gives High jetting, Low flow'.

Item	New Part Number	Old Part Number	Description	QTY
1	S10528	TI-MSZ-PC005-02	Merlin Housing Mounting Plate	1
2	S10529	TI-MSZ-PC006-03	Merlin Housing Body	1
3	S10530	TI-MSZ-PC007-02	Merlin Jetting Valve	1
4	S10531	TI-MSZ-PC008-01	Merlin Jetting Valve Arm	1
5	S10430	TI-3000-01-016	Actuator Swivel Mount	1
6	S10557	TI-10/50/RSE-C	50mm Stroke Actuator	1
7	S10463	TI-89510-M10-16	Fastener, C/Sink Allen Head, M10 x 16	1
8	S10479	TI-89530-M6-12	Fastener, Socket Head, M6 x 12	1
9	S10481	TI-89530-M8-16	Fastener, Socket Head, M8x16	1
10	S10476	TI-89530-M10-75	Fastener, Socket Head, M10x75	17
11	S10483	TI-89550-M8-20	Fastener, Hex Head, M8 x 20	1
12	S10491	TI-89710-M6	Flat Washer, M6	1
13	S10492	TI-89710-M8	Flat Washer, M8	2
14	S10489	TI-89710-M10	Flat Washer, M10	17
15	S10488	TI-89620-M8	Nyloc Hex Nut, M8	1

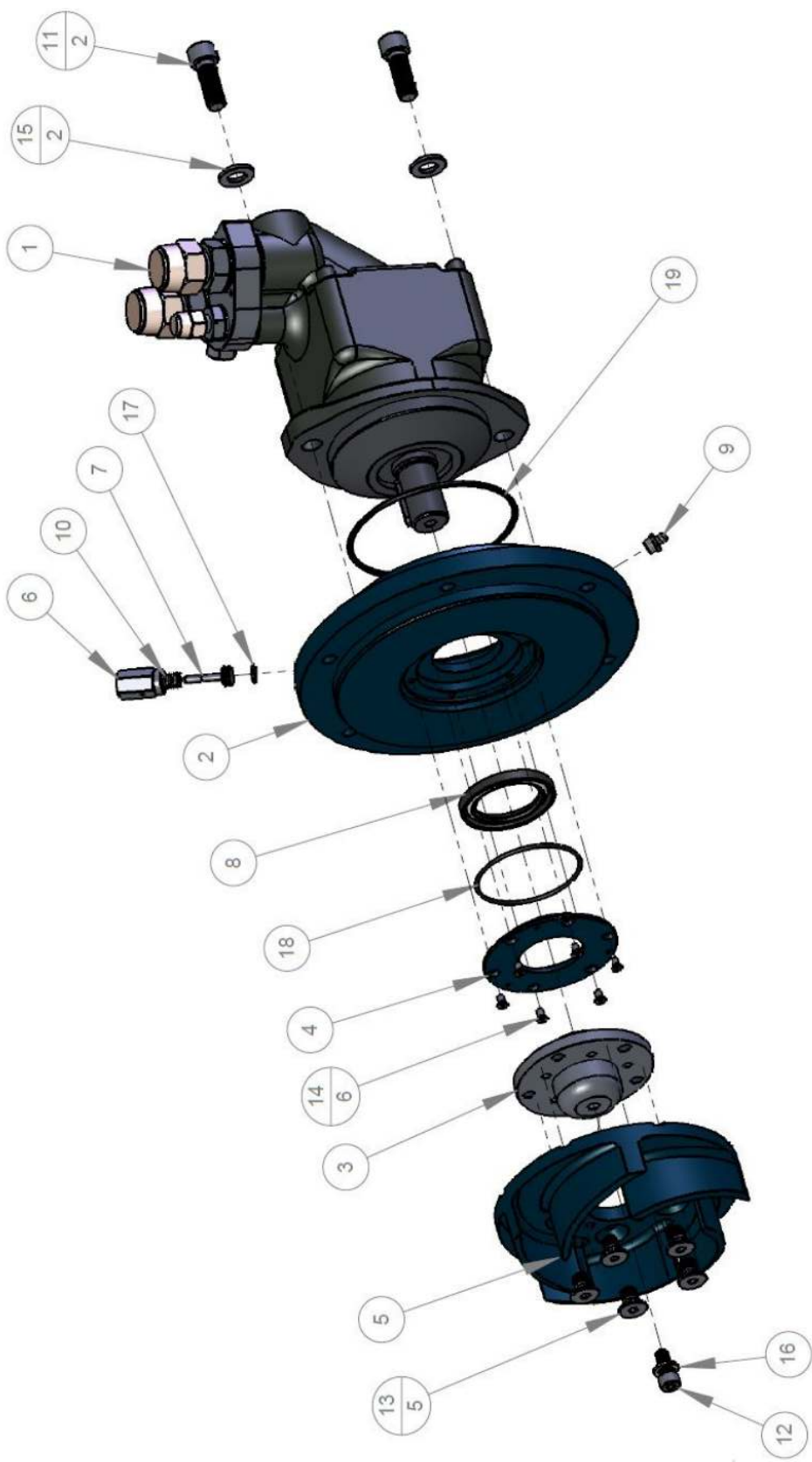

Figure B.3. Merlin Motor Mount Assembly

Main Motor Mount Assembly Instruction

NB: All O-Rings should be suitably greased before installation

1. Place O-ring [19] onto the front face of the F11-19 Volvo Motor Protector Assembly [1].
2. Mount F11-19 Volvo Motor Protector Assembly [1] onto the Motor Mounting Plate [2] fasten using 2 x M12 x 35 SKT CAP Bolts [11] and washer [15] and secure with medium strength Loctite 240.
3. Screw 1/8 Inch NPT Grease Nipple [9] into the Motor Mounting Plate [2].
4. Place O-ring [17] and the C0360 Spring [10] on the Compensator Piston [7] and insert into the compensator case [6].
5. Prime the compensator case hole with grease and screw the compensator assembly into the Motor Mounting Plate [2].
6. Place O-ring [18] into the groove on the Shaft Seal Retainer [5].
7. Insert the DIN 3760R Rotary Seal [8] into the Shaft Seal Retainer [5] ensuring the seal remains normal to the shaft.
8. Fasten the seal retainer assembly with the 6 x M4 x 8 screws [14] and Secure with medium strength Loctite 240.

NB: this unit can be removed using the M4 jacking points

9. Place the Impeller [5] on the Impeller Boss [3] and fasten with 5 x M10 x 16 screws [13] and secure with medium strength Loctite 240.
10. Place the impeller assembly on the motor shaft taking care not to damage the rotary seal (Stretch the seal over the impeller boss before assembly to aid proper mounting)
11. Fasten in place using 1 x M8 x 20 [12] and Dowty Washer [16].
12. Fill the grease cavity with silicon grease ensuring air is allowed to escape by pulling to the compensator piston [7] periodically (best results may be achieved by canting the assembly to ensure the compensator piston is uppermost). The compensator is full when excess grease flows from the port on the compensator case and the piston does not feel spongy.

Item	New Part Number	Old Part Number	Description	QTY
1	N/A	TI-3003-00-000	Motor Protector Assembly	1
2	S10524	TI-MSZ-PC001-03	Merlin Motor Mounting Plate	1
3	S10525	TI-MSZ-PC002-01	Merlin Impeller Boss to JK120H	1
4	S10527	TI-MSZ-PC004-01	Merlin Shaft Seal Retainer	1
5	S10526	TI-MSZ-PC003-01	Merlin Impeller Blade	1
6	S10434	TI-3000-01-037	Compensator Case	1
7	S10435	TI-3000-01-038	Compensator Piston	1
8	S10543	TI-R-SS-45-65-6	Seal, Metric Oil, Type R, S/S Spring	1
9	S10462	TI-89450	1/8 NPT Grease Nipple, 316 S/S	1
10	S10517	TI-C0360-026-1000-S	Compensator Spring	1
11	S10478	TI-89530-M12-35	Fastener, Socket Head, M12 x 35	2
12	S10482	TI-89530-M8-20	Fastener, Socket Head, M8 x 20	1
13	S10463	TI-89510-M10-16	Fastener, C/Sink Allen Head, M10 x 16	5
14	S10471	TI-89510-M4-8	Fastener, C/Sink Allen Head, M4 x 8	6
15	S10490	TI-89710-M12	Flat Washer, M12, SS A4	2
16	S10460	TI-89305	Seal, Dowty, M8, Self Centre, S/S Ring	1
17	S10510	TI-BSI0110-10NI70	'O' Ring, NI70, 11.00mmID x 1.00mm	1
18	S10514	TI-BSI0700-20NI70	'O' Ring, NI70, 70.00mmID x 2.00mm	1
19	S10516	TI-BSI1120-30NI70	'O' Ring, NI70, 112.00mmID x 3.00mm	1

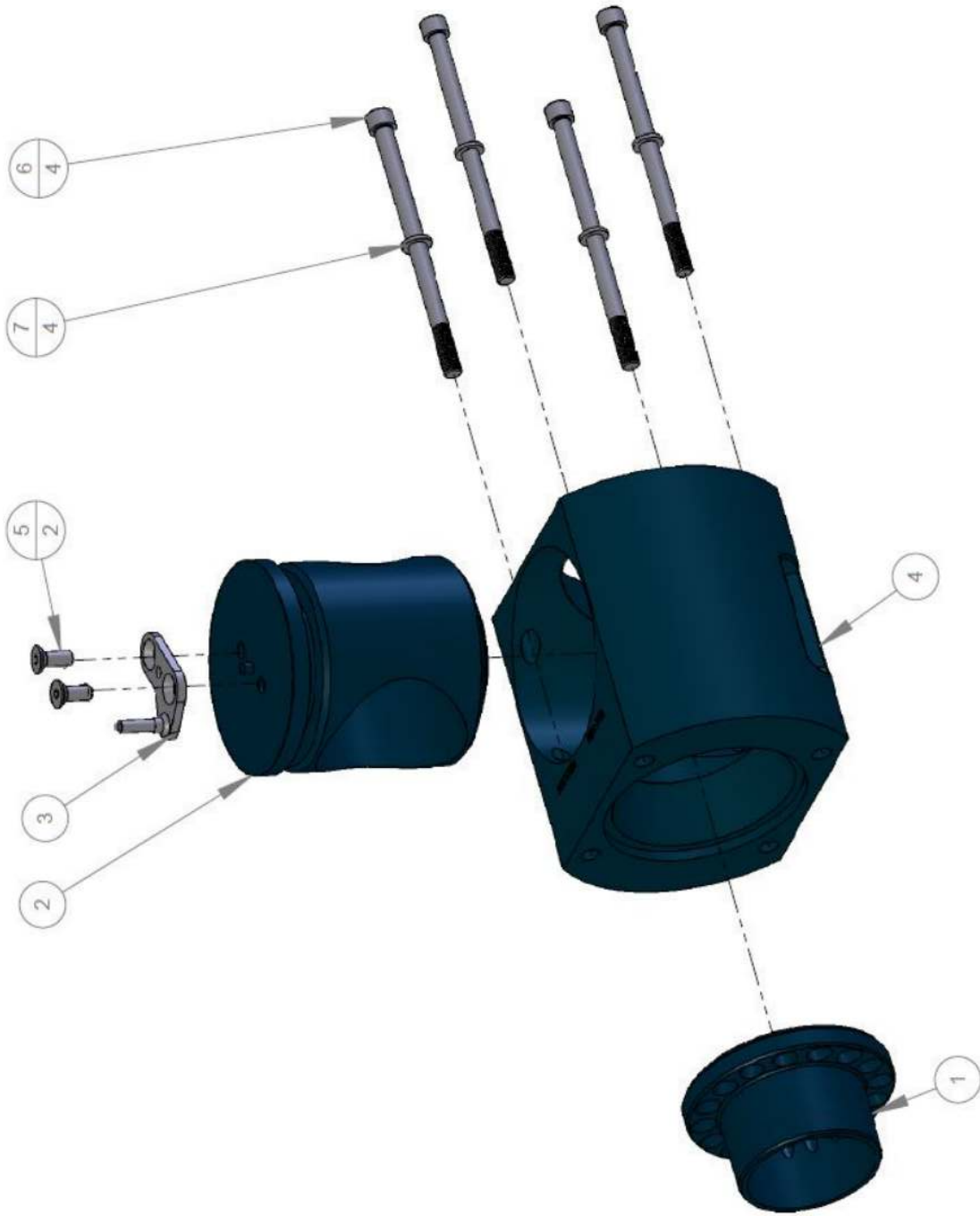

Figure B.4. Merlin Diffuser Assembly

Merlin Diffuser Assembly Instruction

1. Screw the Eductor [1] into the Diffuser Body [4]
2. Place the Reverse Flush Valve into the Diffuser Body [4] and secure by sliding in the 4 x M12 x 195 SKT CAP Screws [6] and Clevis Washers [7]
3. Secure the Reverse Valve Actuator Arm [3] onto the Reverse Flush Valve [2] and secure in place using the 2 x M10 x 25 CSK SKT Screws [5] with a small amount of medium strength Loctite 240 on countersunk face.
4. Ensure the Reverse Flush Valve [2] is free to rotate in the body.

Item	New Part Number	Old Part Number	Description	QTY
1	S10532	TI-MSZ-PC009-01	Merlin Eductor	1
2	S10533	TI-MSZ-PC010-01	Merlin Reverse Flush Valve	1
3	S10534	TI-MSZ-PC011-01	Merlin Reverse Valve Actuator Arm	1
4	S10535	TI-MSZ-PC012-01	Merlin Diffuser Body, Black	1
5	S10464	TI-89510-M10-25	Fastener, C/Sink Allen Head, M10 x 25	2
6	S10477	TI-89530-M12-195	Fastener, M12x195 Socket Head Bolt, S/S	4
7	S10495	TI-89760-M12	M12 Narrow Flat Washer, SS A4	4