

SuperZip

Product Manual

0711-SOM-00003, Issue: 05



© Trittech International Ltd

The copyright in this document is the property of Trittech International Ltd. The document is supplied by Trittech International Ltd on the understanding that it may not be copied, used, or disclosed to others except as authorised in writing by Trittech International Ltd.

Trittech International Ltd reserves the right to change, modify and update designs and specifications as part of their ongoing product development programme.

All product names are trademarks of their respective companies.

Table of Contents

Help & Support	4
Warning Symbols	5
1. Introduction	6
2. Specification	7
3. Installation	8
3.1. Mounting	8
3.2. Water Hoses	9
3.3. Hydraulics	10
3.4. Seal Compensator	12
4. Operating Principles	13
4.1. Suction	13
4.2. Jetting	14
4.3. Testing in Air	14
5. Maintenance	15
5.1. General Guidelines	15
5.2. Basic Procedures	15
5.3. Dismantling	17
5.4. Re-assembly	18
6. Troubleshooting	23
A. Motor Protector Assembly Procedure	24
B. Parts List and Exploded Diagram	26

Help & Support

First please read this manual thoroughly (particularly the Troubleshooting section, if present). If a warranty is applicable, further details can be found in a Warranty Statement at the end of the manual.

Tritech International Ltd can be contacted as follows:

	Mail	<i>Tritech International Ltd</i> Peregrine Road Westhill Business Park Westhill, Aberdeenshire AB32 6JL, UK
	Telephone	++44(0)1224 744 111
	Fax	++44(0)1224 741 771
	Email	support@tritech.co.uk
	Website	www.tritech.co.uk

Prior to contacting *Tritech International Ltd* please ensure that the following is available:

1. The Serial Numbers of the product and any *Tritech International Ltd* equipment connected directly or indirectly to it.
2. Software or firmware revision numbers.
3. A clear fault description.
4. Details of any remedial action implemented.



Contamination

If the product has been used in a contaminated or hazardous environment you *must* de-contaminate the product and report any hazards *prior* to returning the unit for repair. *Under no circumstances should a product be returned that is contaminated with radioactive material.*

The name of the organisation which purchased the system is held on record at *Tritech International Ltd* and details of new software or hardware packages will be announced at regular intervals. This manual may not detail every aspect of operation and for the latest revision of the manual please refer to www.tritech.co.uk

Tritech International Ltd can only undertake to provide software support of systems loaded with the software in accordance with the instructions given in this manual. It is the customer's responsibility to ensure the compatibility of any other package they choose to use.

Warning Symbols

Throughout this manual the following symbols may be used where applicable to denote any particular hazards or areas which should be given special attention:



Note

This symbol highlights anything which would be of particular interest to the reader or provides extra information outside of the current topic.



Important

When this is shown there is potential to cause harm to the device due to static discharge. The components should not be handled without appropriate protection to prevent such a discharge occurring.



Caution

This highlights areas where extra care is needed to ensure that certain delicate components are not damaged.



Warning

DANGER OF INJURY TO SELF OR OTHERS

Where this symbol is present there is a serious risk of injury or loss of life. Care should be taken to follow the instructions correctly and also conduct a separate Risk Assessment prior to commencing work.

1. Introduction

The SuperZip is a development from the *Tritech International Ltd* Zip Pump and ZipJet range of products.

The integrated eductor based excavation system is designed to pump mud, sand, gravel, drill cuttings and shale without the risk of blockage. A heavy duty cylinder reverses the flow at the nozzle to eject any object which may be causing an obstruction. A second cylinder operates a diverter valve to provide a powerful direct jet to break up heavy and cohesive seabed mud and sand prior to excavation.

Key features include:

- Separately compensated seal void to minimise ROV hydraulic oil contamination
- Easy seal change and maintenance
- Lift handle and stabiliser foot
- Suction and jetting nozzles aligned
- Optional feed water filter
- Optional integrated suction and jetting nozzles
- Modular pump core to simplify maintenance

2. Specification

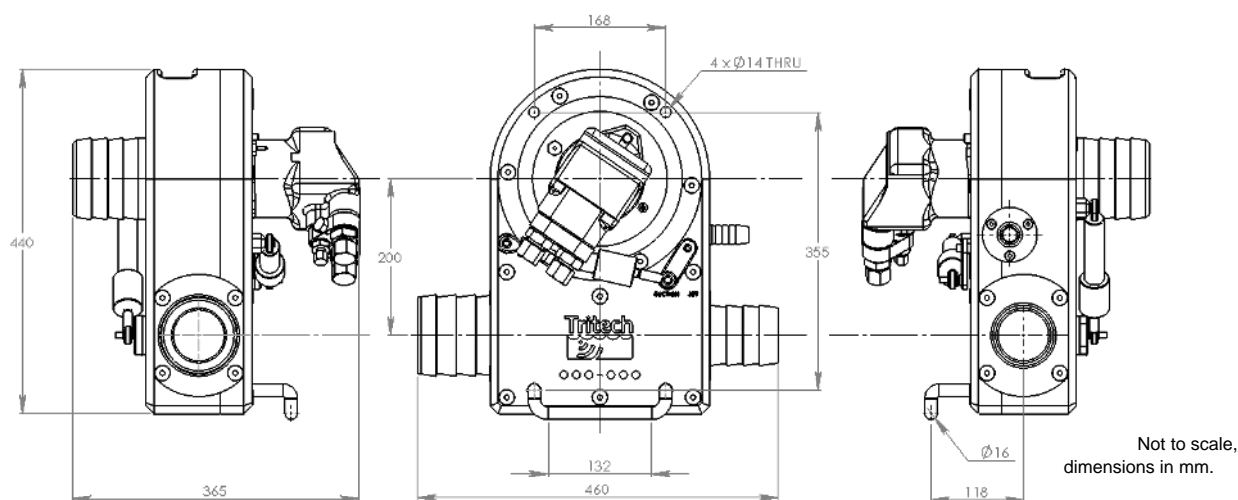

Warning

Never use the same size fitting for pressure hoses and the case drain. If this is done there is significant risk of incorrect hook-up which will lead to pressure being applied to the motor casing and could result in an explosion and personal injury.

Hydraulic Motor Input	
Pressure	150 to 220 Bar (2200 to 3200 psi)
Flow	40 to 60 litres/min (11 to 16 USgpm)

Hydraulic Fittings	
Motor A & B	No. 12 JIC male
Motor case drain	No. 6 JIC male
Actuator Connection	No. 4 JIC male

Actuator	
Min. pressure	110 Bar (1595 psi)
Max. pressure	240 Bar (3480 psi)

Check Valve	
Norm.	Tritech Volvo Protector Assembly
Alt.	Integrated Hydraulics FPR-1/22-0.5 (cracking pressure 0.5 bar)

Output	
Jetting performance	1000 litre/min @ 2 Bar (270 USgpm)
Suction flow	500 - 1000 litres/min (135 to 270 USgpm)
Solids removal rate	5 - 10 tonnes/hour (184 - 368 lb/min)

Nozzle Dimensions	
Jetting	25.4mm (1")
Discharge	104mm (4")
Suction	77.3mm (3")
Clean Water Inlet	104mm (4")

Weight and Materials	
Weight in air	25kg (55lb)
Weight in water	11kg (24lb)
Materials	Nylacast, UHMWPE

3. Installation



Warning

Do not power the pump or hydraulic valve actuators until all hoses are properly connected to the pump.

There is a serious risk of injury to fingers if inserted into either the power water intake or the pump delivery port.

If undertaking any testing operations suitable guards and other safety measures must be in place.

3.1. Mounting

The pump may be mounted in any orientation on the vehicle. There are four mounting holes each with 12mm diameter clearance. Two of these are occupied by the stabiliser foot, which may either be removed or used itself as a mounting. If desired a second stabiliser bar may be fitted in the alternative hole set

The pump should not be mounted using the motor or hose nozzles as attachment points.

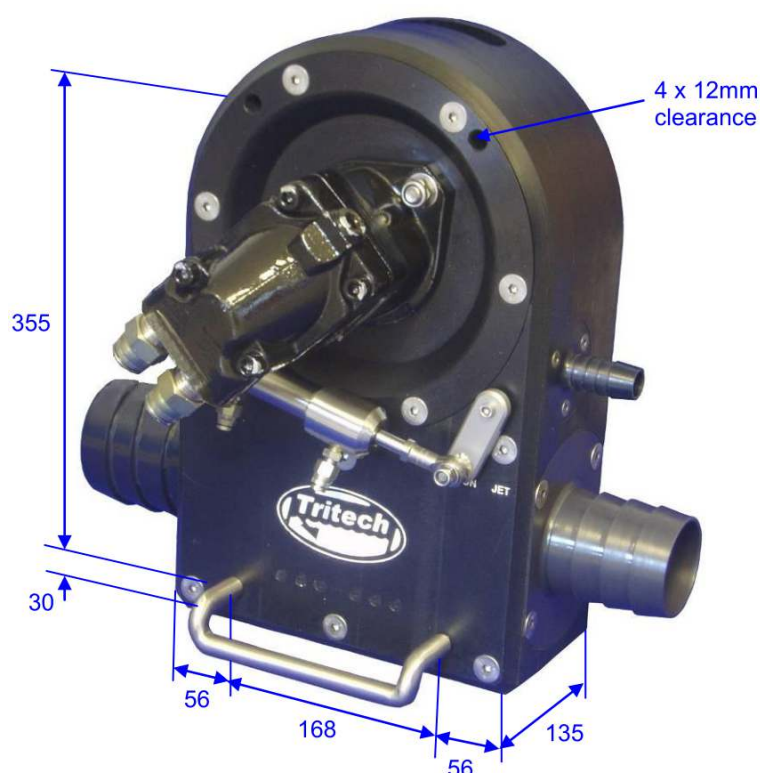

Figure 3.1. Mounting Holes

3.2. Water Hoses

Hose Types



Note

The recommended hose type is the Kanaline AW/Hydrasun Arizona

Kanaline AW hoses have plastic reinforcement and a semi-transparent wall which assists in visual inspection for damage or blockages. Alternative makes of suction and discharge hose may be used provided that they have a smooth internal bore.

Any crush resistant PVC coil strengthened hose may be used if the recommended hoses are not available.

Lay-flat style hoses are not recommended for discharge.

Fittings

Use standard Kanaline fittings or heavy-duty worm drive clips. Use of heavy-duty two bolt clamps will result in damage to the hose connections on the pump unit.

Clean Suction Intake Screen

It is recommended that a *Tritech International Ltd* supplied suction strainer is used with the pump. If using another strainer it must meet the following specifications:

- Maximum hole size: square mesh of 40mm aperture or circular perforations of 60mm diameter.
- Minimum total free flow area: 0.016m²

The pump should not be operated in any circumstances without a suction screen.

Dredge Suction Nozzle

Suction nozzles should be designed with a nozzle cross-section area of approximately 40cm²

Smaller nozzles may be used but material removal rates will be reduced. Larger nozzles are of no benefit and will reduce performance.

A nozzle guard should be fitted that will pass a maximum of a 40mm diameter sphere or 35mm sided cube. The pump can pass single objects of a larger size, but if it takes in a stream of objects then blockages can occur.

Jet Nozzle

The recommended sizes are 14 to 19mm diameter or an equivalent area.

The optimum size will need to be determined by trial because the water output from the power pump will vary depending on the oil pressure and flow available from the ROV hydraulic system.

3.3. Hydraulics

Oil

The pump should be operated using a premium grade mineral based hydraulic oil of ISO VG 22 to 32

Filtration

The hydraulic system filtration must be to a minimum of 10µm absolute standard. A 10µm nominal standard is regarded as inadequate.

The recommended filtration is UN elements produced by Pall Industrial Hydraulics Ltd. or equivalent products.

Hook-up

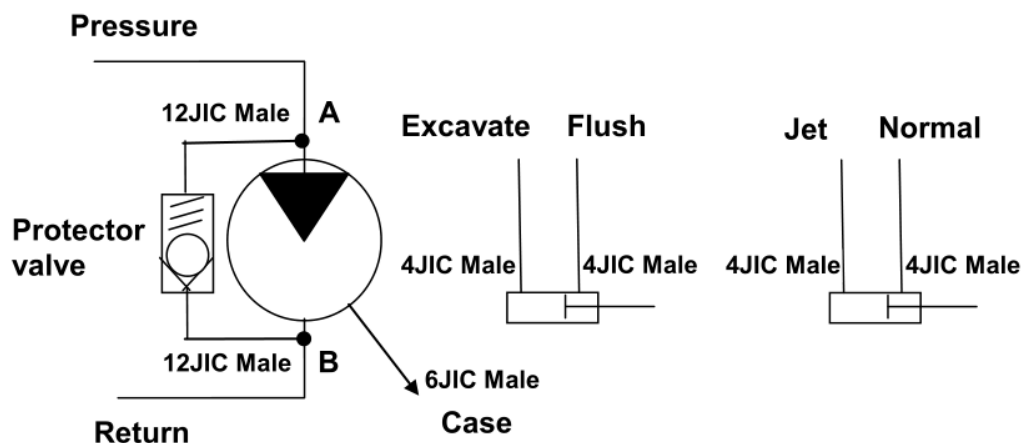

Figure 3.2. Hydraulic Hook-up Orientation

The pump is configured for correct rotation when the hydraulic supply is connected to the "A" port of the Volvo motor and the return line to the "B" port.

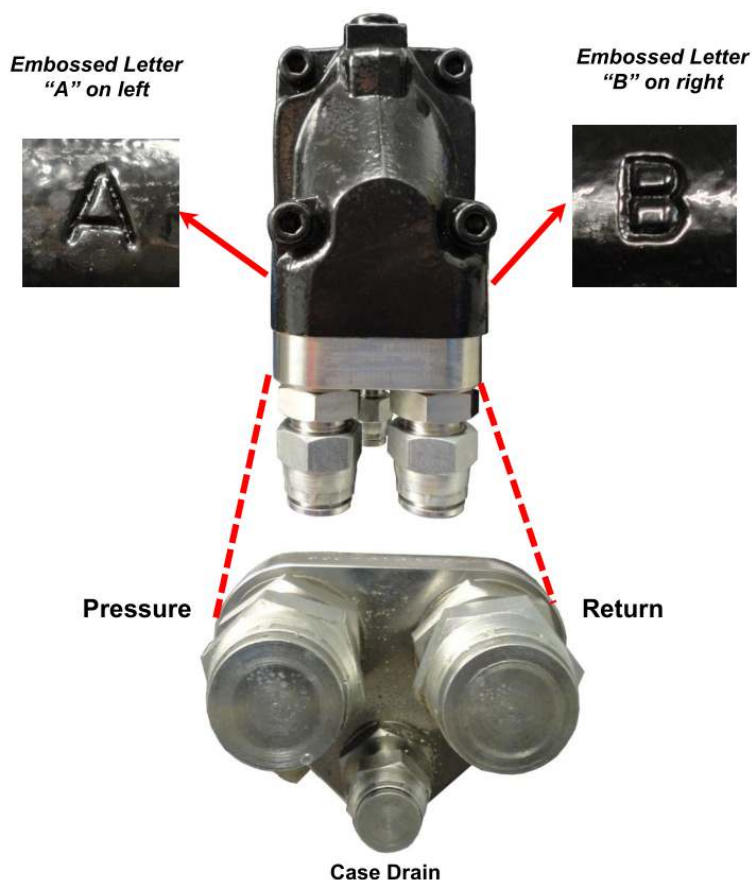

Figure 3.3. Motor viewed when fitted to SuperZip with hydraulic fittings downwards

The drain connection from the motor back to the tank is required to be a minimum of $\frac{3}{8}$ inch bore. The drain line should return straight to the tank without restriction. It is possible to connect the drain line back to a larger bore drain manifold, which has been correctly sized to accommodate all drains attached to it.

The drain line should not be connected to any return flow lines.



Warning

Self-sealing quick disconnect connectors should not be used on the drain line. Such connectors, if incorrectly fitted, may result in pressurisation of the motor casing which could fail explosively under pressure resulting in significant risk of personal injury.

Required Hydraulic Flow

For the Volvo F11-10 motor the vehicle hydraulic system should be capable of supplying a flow rates and pressure detailed in Chapter 2, *Specification*.

Achieving the required flow in an unloaded condition is no guarantee that the supply can actually be met in working conditions.

It is recommended that the installation be checked using a hydraulic flow meter equipped with a loading valve which can simulate the motor running under load.

In order to avoid pressure losses a minimum of ½ inch bore pipes or hoses are used on the flow and return lines (¾ inch or larger is recommended).

3.4. Seal Compensator

The SuperZip has a separately compensated seal void which is grease filled and has its own miniature compensator.

On installation the compensator level should be checked. The stem has an indicator groove showing when it is full. If necessary gently apply grease via the grease nipple provided until the groove just shows or the grease is expelled from the overflow.



Caution

Pump the grease very slowly to avoid building up excessive pressure in front of the motor face.

4. Operating Principles

4.1. Suction

The SuperZip pump is based on the principles of the annular eductor pump. It has a monoblock configuration and common body within which the educator pump and power pump are contained.

The power for the eductor section of the pump is provided by a stream of clean water driven by the centrifugal impeller.

Clean water is drawn into the inlet, passes through the impeller of the power pump and is then injected into the main suction stream via the annular eductor nozzle.

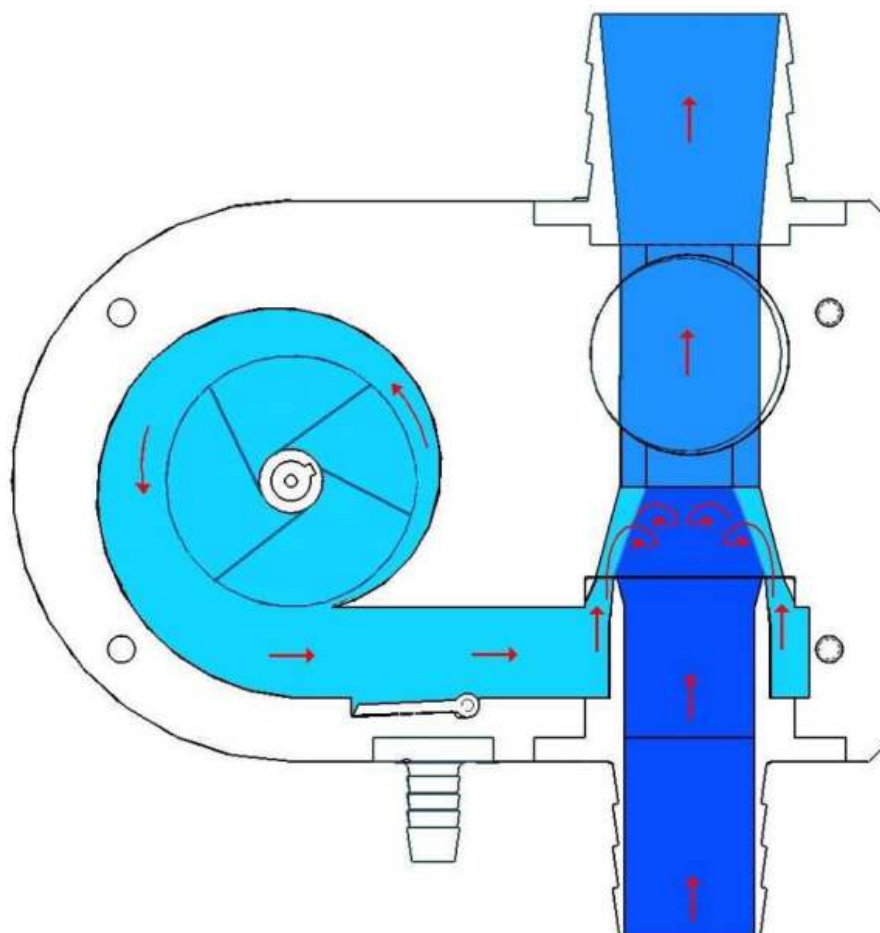

Figure 4.1. SuperZip Flow Diagram

The main suction stream can contain a heavy concentration of sand, mud, gravel and drilling debris. The pump has a retro flush valve just behind the eductor and when this is closed (operating cylinder extended) the power fluid

is then directed to the suction nozzle. This feature can be used to clear a blocked suction nozzle or to complete a deburial operation by blowing away the last sand and mud from around an object.

The optimum performance will be obtained with the nozzle pushed deep into the debris and agitated gently. Where a large amount of debris is encountered it will be necessary to keep withdrawing the nozzle.

4.2. Jetting

The body of the pump contains a diverter vane. The purpose of the vane is to switch the flow of the power pump water between the suction educator and the jetting outlet.

The diverter should be operated fully in one direction or the other. Attempting to share the flow between the eductor and the jet nozzle by using a mid position will result in poor performance from both. The diverter is set for suction when the cylinder is retracted and for jetting with the cylinder extended.

4.3. Testing in Air



Warning

Under no circumstances must the flow be allowed to exceed 70 litres per minute when testing in air.

There is no back pressure on the impeller to control its speed and many vehicle hydraulic systems are capable of higher deliveries when there are no thrusters running. Motor over-speed can cause a catastrophic failure

To avoid excessive wear and the possibility of damaging the impeller and body, the unit should not be run for extended periods out of the water (no more than about 30 seconds). This is especially true when the unit is new. Absence of water around the plastic removes the natural cooling mechanism and may result in the moving parts becoming misshapen due to the heat.

5. Maintenance

5.1. General Guidelines



Warning

Do not power the pump or hydraulic valve actuators until all hoses are properly connected to the pump.

There is a serious risk of injury to fingers if inserted into either the power water intake or the pump delivery port.

If undertaking any testing operations suitable guards and other safety measures must be in place.

The pump is designed for low maintenance operation. The main materials are stainless steel and wear resistant polymer plastics.

The only internal moving parts that may need maintenance are:

- The power pump impeller
- The hydraulic motor and shaft seal
- The retro-flush valve spool
- The diverter valve vane
- Impeller water seal

The eductor set may need replacement after prolonged use with extremely abrasive materials or if aggressive chemicals have been encountered.

5.2. Basic Procedures

Hydraulic Motor Shaft Seals

The pumps are fitted with either an 'H' (red) or 'V' (brown) type seal. The type V is the standard seal and is high pressure, high temperature.

Replacement of seals with anything other than a genuine seal (or *Tritech International Ltd* supplied seal) will invalidate the warranty.

Pre-dive

Before use check the following:

- The level of the seal compensator (re-charge if necessary)
- All hoses are secure
- All mountings are secure
- Clean water suction strainer is in place and clear



Note

If the vehicle is inactive for more than 48 hours run fresh water into the clean water suction strainer for a few minutes and then spin the hydraulic motor for about 15 seconds (taking care not to allow it to over-speed).

Storage

If the pump is removed from the vehicle, then the hydraulic ports should be blanked off with metal caps and the unit washed out with fresh water.

Leave the actuator valves in their retracted position.

Visually inspect the leading edges of the power pump impeller for damage and erosion.

Up to four blades may have leading edge damage of 5mm width and 4mm depth before replacement becomes essential.



Note

If the majority of leading edges are eroded more than 3.5mm back from the bore of the inlet nozzle then consideration should be given to replacing the impeller.

5.3. Dismantling

In order to dismantle the pump the following tools will be required:

- 13 and 19mm socket
- 4,5,6 and 8mm Allen key
- Torque wrench
- 3 jaw puller
- Grease gun
- Anti-seize compound
- Silicon grease
- Loctite "Studlock" medium strength

Removal of hydraulic motor, power pump impeller and impeller seal replacement

1. Disconnect all hydraulic hoses from the motor and fit caps to the ports.
2. Remove the 6 bolts holding the motor mounting plate to the pump (this will include removing the jetting actuator retaining bolt for access).
3. Remove the mounting plate/motor/impeller assembly. This also provides access to the impeller seal.
4. Remove the four countersunk setscrews securing the impeller to the boss (these will be tight since they are retained by Loctite). Remove the impeller.
5. Remove the retaining setscrew and end-cap from the end of the motor shaft.
6. Using a suitable 3 jaw puller remove the impeller boss from the motor shaft.

Removal of the retro-flush valve



Note

This requires splitting the pump casing.

1. Disconnect all hoses and remove the pump from the vehicle.
2. Remove the motor assembly as above.

3. Remove the valve core arm by releasing the two securing bolts.
4. Remove the 6 remaining case bolts and the 11 bolts on the hose nozzles and separate the casing.
5. The valve core is now free for removal.

Removal of the diverter valve vane



Note

This requires splitting the pump casing.

1. Proceed as above as far as separating the case sections.
2. Remove the diverter valve cam by releasing the M6 SKT CAP screw.
3. The diverter arm can now be removed from the case.

5.4. Re-assembly

Hydraulic motor and impeller

Fit the impeller seal, with the lip facing away from the motor side as shown in Figure 5.1, “Impeller Seal”, into the centre spigot and press down until output lip meets the shoulder. Place the seal retaining ring on top ensuring it is centred correctly (as shown in Figure 5.2, “Seal Retaining Clip”).

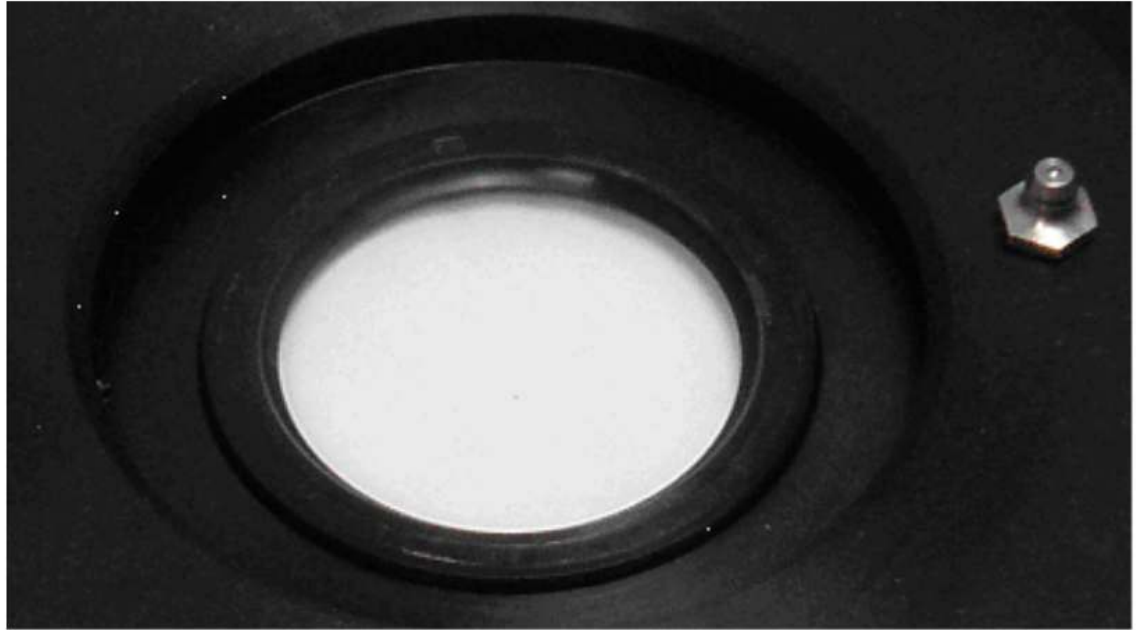

Figure 5.1. Impeller Seal

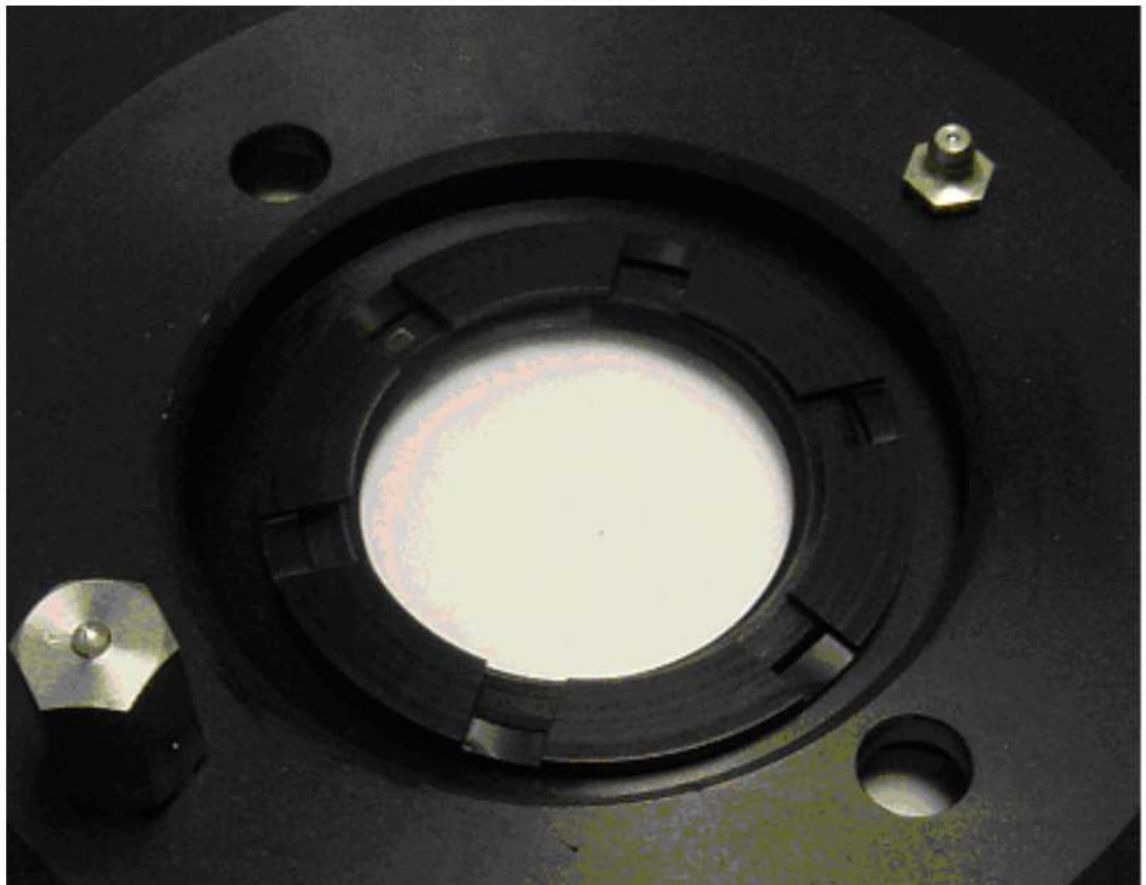

Figure 5.2. Seal Retaining Clip

Place the ID100x2mm o-ring onto the motor and apply some silicon grease around the surface. Mount the motor on the motor mount disk and secure (see Figure 5.3, “Motor Mount Disk”).

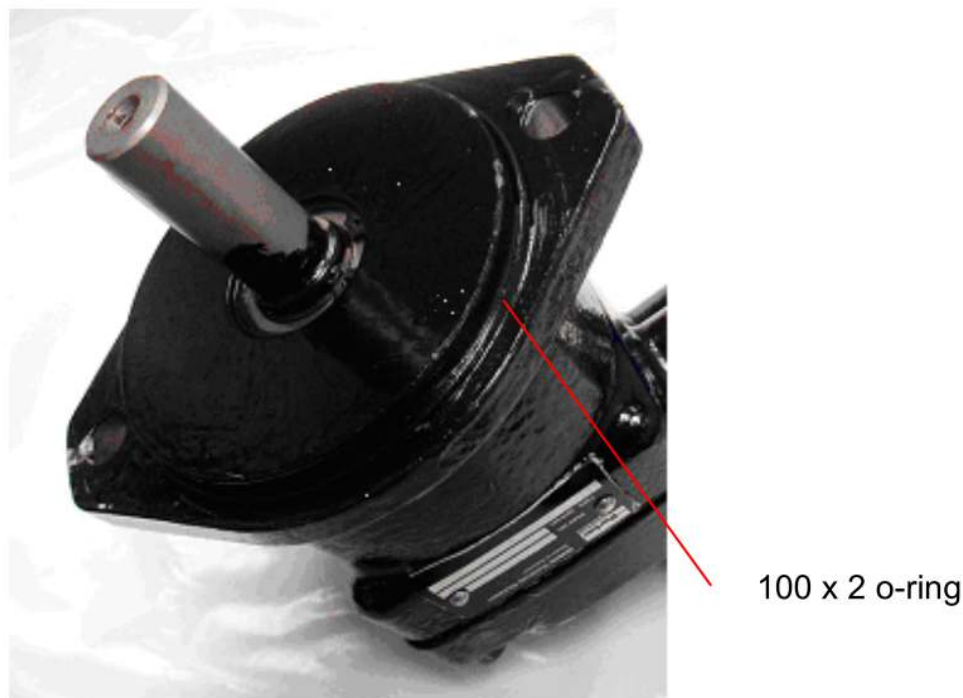

Figure 5.3. Motor Mount Disk

Apply some anti-seize grease to the motor shaft before fitting the impeller. Press the impeller boss onto the shaft right up to the shoulder.

Place the ID20x3.5mm o-ring over the top of the motor shaft, assemble the retainer onto the shaft end and secure the setscrew using a small quantity of Loctite.

Replace the impeller on the boss and secure the four countersunk screws with Loctite.

Slowly fill the motor face cavity with grease until the compensator piston shows the fill mark and grease flows out of the relief port (see Figure 5.4, “Compensator Piston”).

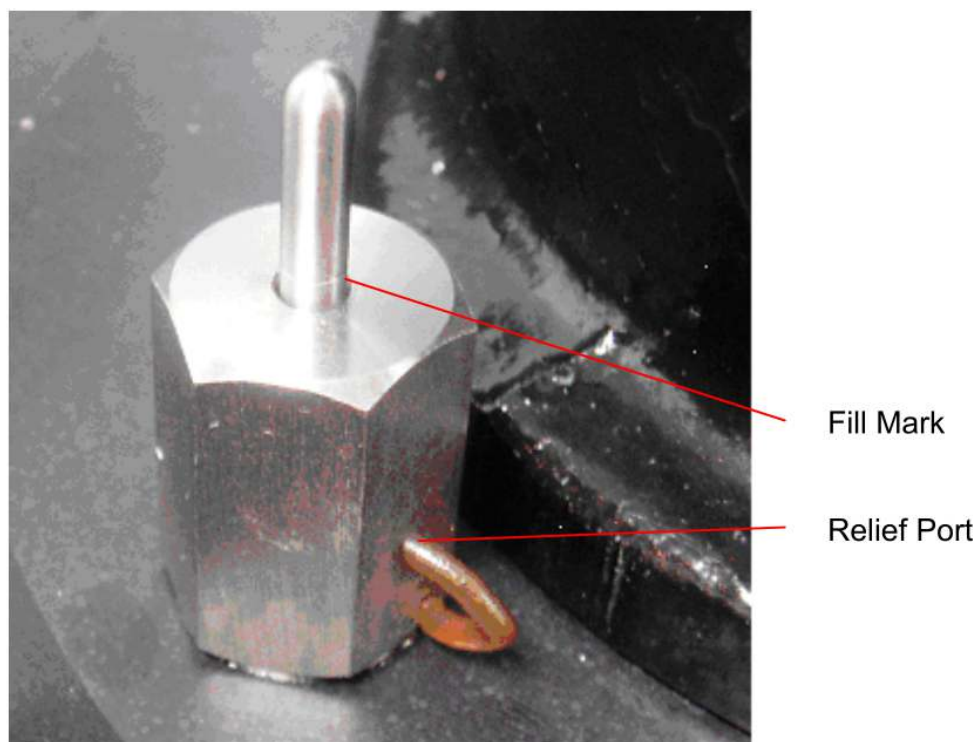

Figure 5.4. Compensator Piston

Retro-flush valve

Check that the core is a loose fit in the case body, and that it is clear of dirt.

Place the case halves together and assemble as directed.

Fit the retro flush valve cam to the valve and place a small amount of Loctite under the screw heads and tighten in place. Fit the actuator with the valve fully open and the cam pointing across the pump body.

Diverter valve vane

Adjust the cylinder end bearing to align with the actuator-mounting nut.

Lock the setting using the locknut, and a small amount of Loctite.

Place the case halves together and assemble as directed.

Fit the actuator arm such that the valve is open and the arm points to the suction point. Attach the actuator to the arm using the supplied M8 nut and washer.

Case

Place the case halves together and insert the hose barbs. Secure all screws in place using a small amount of Loctite under the cap heads and tighten in place.

Re-fit motor assembly and secure all screws in place using a small amount of Loctite under the cap heads and tighten in place.

DO NOT OVER-TIGHTEN CASE SCREWS

	Metric	Imperial
M12 motor bolts	15 Nm	11 lb _f ·ft
M10 case, motor plate & nozzle bolts	8 Nm	6 lb _f ·ft
M6 jetting nozzle bolts	4 Nm	3 lb _f ·ft

6. Troubleshooting

If the pump is suffering from poor performance carry out the following checks:

- Check that the clean water suction strainer is clear and that there are no blockages in the hose.
- Check that the retro-flush valve is opening fully.
- Check that the suction hose reinforcement is intact and that there are no signs of the hose collapsing under suction.
- Check that the discharge hose is not damaged or kinked.
- Remove the clean water suction hose from the pump and check that the face of the impeller is not obstructed by material such as rope fibre or shreds of plastic bags.
- Check that the hydraulic motor runs freely without excessive noise or vibration.
- Check that the hydraulic flow meets the specification.

Appendix A. Motor Protector Assembly Procedure



Assembly Instruction

Remove any existing port fittings from the F11-10 Volvo motor. Ensure that the top face of the motor is free from any debris such as paint, dirt or grit. Clean and degrease the surface.

1. Place the 10 mm High Carbon chrome Alloy Ball Bearing [4] into the Valve Block F11-10 [3] and seat in place.
2. Apply a small amount of anti-galling compound to the thread and a small amount of Molykote 111 silicon grease to the O-rings on the Plug Hex Head [6].
3. Place the Compression Spring [5] into the Valve Block F11-10 8 and secure in place by tightening down the Plug Hex Head [6].
4. Place a SEAL Dowty 3/4" Self Centre S/S Ring [7] on each 3/4- 14 BSP - JIC 12 Connector [1].
5. Place a SEAL Dowty 3/8" Self Centre S/S Ring [8] on the 3/8-19 BSP JIC 6 Connector [2].
6. Place the assembled components from instruction 4 & 5 into the top of Valve Block F11-10 [3].
7. Grease with Molykote 111 and place an O-ring 32 x 2 [10] into each groove on the Valve Block F11-10 [3] Base.
8. Grease with Molykote 111 and place an O-ring 20 x 2 [9] into the groove on the Valve Block F11-10 [3] Base.
9. Apply a small amount of anti-galling compound to the threads of the BSP Connectors [1] & [2]

10 Mount the assembled components from instruction 8 onto the F11-10 Volvo Motor [13] and tighten down using an adjustable spanner.

11 Place the Cap, Female No 12 JIC Carbon Steel [11] & Cap, Female No 6 JIC Carbon Steel [12] onto the BSP Connectors [1] & [2] and hand tighten

Item	New Part Number	Old Part Number	Description	QTY
1	S10446	TI-3002-01-002	Motor Protector Connector, 3/4-14 BSP	2
2	S10447	TI-3002-02-003	Motor Protector Connector, 3/8-19 BSP	1
3	S10445	TI-3002-01-001	Motor Protector Valve Block, F11-10	1
4	S10497	TI-90100-10	Ball Bearing, 10mm High Carbon Chrome	1
5	S10522	TI-D21770	Spring, Compression	1
6	S10461	TI-89401	Plug, Hex Head, 6P50NSS, 316 S/S	1
7	S10459	TI-89301	Seal, Dowty, 3/4, Self-Centre, S/S Ring	2
8	S10458	TI-89300	Seal, Dowty, 3/8, Self-Centre, S/S Ring	1
9	S10511	TI-BSI0200-20NI70	O-Ring 20 x 2	1
10	S10513	TI-BSI0320-20NI70	O-Ring 32 x 2	2
11	S10457	TI-89202	Cap, Female JIC12 Carbon Steel	2
12	S10456	TI-89201	Cap, Female JIC6 Carbon Steel	1
13	S10453	TI-89-008-592P	F11-10 Volvo Motor	1

Appendix B. Parts List and Exploded

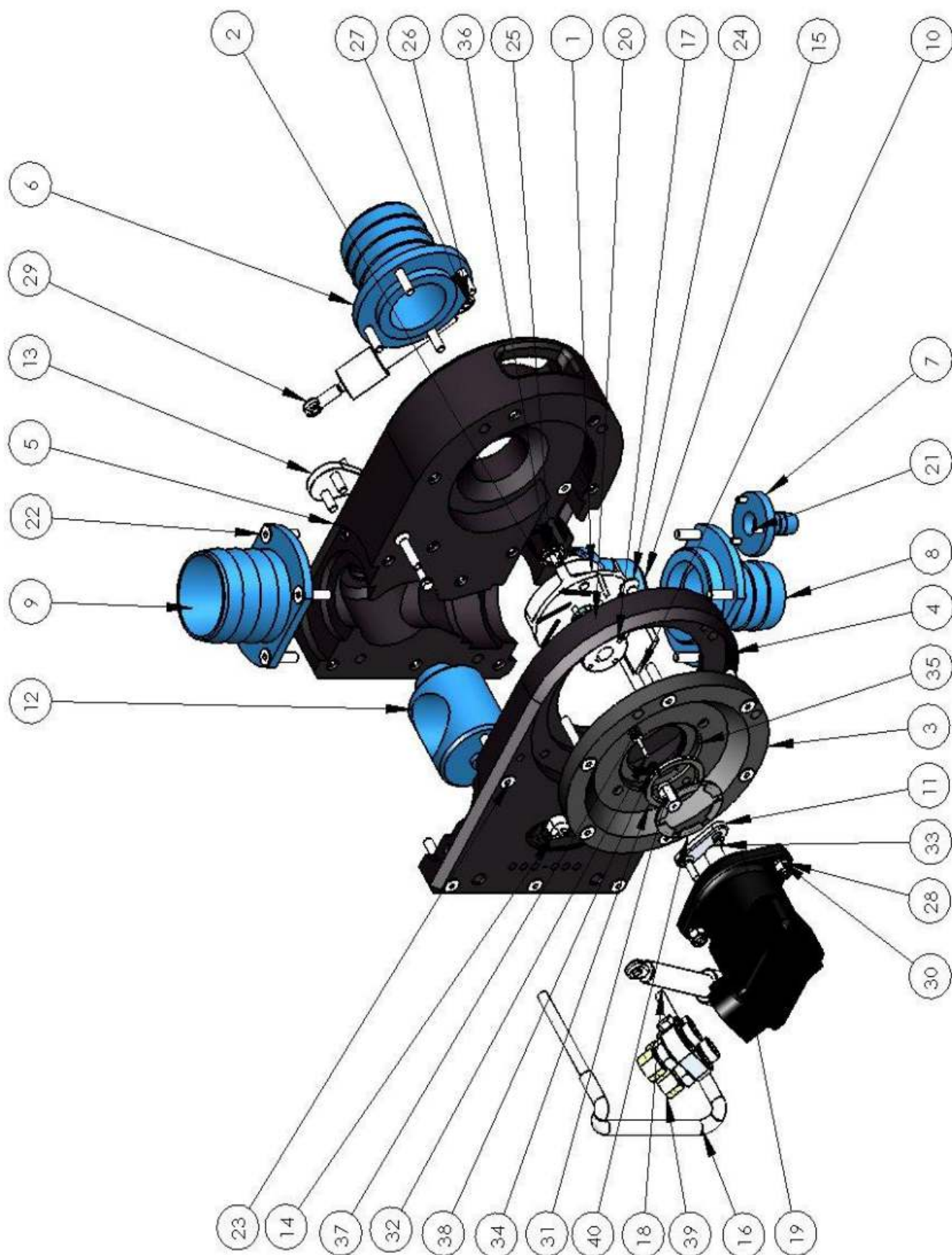

Figure B.1. SuperZip Exploded Diagram

No.	Part Number	Old Number	Description	QTY
1	S10443	TI-3000-05-001	5 Vane Impeller	1
2	S10436	TI-3000-02-002	Impeller Retainer	1
3 ^A	S10444	TI-3000-06-003	Motor Mount	1
4 ^{A+}	S10441	TI-3000-04-004	Motor Side Case	1
5 ^{A+}	S10442	TI-3000-04-005	Inlet Side Case	1
6	S10425	TI-3000-00-006	Clean Water Inlet Nozzle	1
7	S10426	TI-3000-01-007	Jetting Nozzle	1
8 ^A	S10439	TI-3000-03-008	Eductor Inlet Nozzle	1
9	S10427	TI-3000-01-009	Evacuation Nozzle	1
10 ^A	S10437	TI-3000-02-010	Jetting Valve	1
11	S10428	TI-3000-01-011	Jetting Valve Cam	1
12 ^A	S10429	TI-3000-01-013	Reverse Flush Valve	1
13	S10440	TI-3000-03-014	Reverse Flush Cam	1
14	S10430	TI-3000-01-016	Actuator Swivel Mount	2
15 ^A	S10431	TI-3000-01-034	Eductor	1
16	S10432	TI-3000-01-035	Base Stand	1
17	S10433	TI-3000-02-036	Impeller Boss	1
18	S10557	TI-10/50-0-RSE-C	50 Stroke Actuator	2
19	S10453	TI-89-008-592P	F11-10 Volvo Motor	1
20	S10472	TI-89510-M6-16	C/Sink Allen Head, M6 x 16, SS	4
21	S10474	TI-89510-M6-25	C/Sink Allen Head, M6 x 25, SS	3
22	S10465	TI-89510-M10-45-FT	C/Sink Allen Head, M10 x 45, SS	13
23	S10466	TI-89510-M10-70-FT	C/Sink Allen Head, M10 x 70, SS	13
24	S10468	TI-89510-M12-40	C/Sink Allen Head, M12 x 40, SS	2
25	S10480	TI-89530-M6-20	Socket Head, M6 x 20, SS	2
26	S10483	TI-89550-M8-20	Hex Head, M8 x 20, SS	2
27	S10492	TI-89710-M8	M8 SS Washer	4
28	S10490	TI-89710-M12	M12 SS Washer	2
29	S10488	TI-89620-M8	M8 SS Nyloc Nut	2
30	S10487	TI-89620-M12	M12 SS Nyloc Nut	2
31	S10434	TI-3000-01-037	Compensator Case	1
32	S10435	TI-3000-01-038	Compensator Piston	1
33	S10462	TI-89450	1/8 NPT SS Grease Nipple	1
34	S10544	TI-R-SS-58-75-5	Seal, Metric Oil, Type R, S/S Spring	1
35	S10515	TI-BSI1000-20NI70	'O' Ring, NI70, 100.00mmID x 2.00mm CS	1
36	S10512	TI-BSI0200-35NI70	'O' Ring, NI70, 20.00mmID x 3.50mm CS	1
37	S10510	TI-BSI0110-10NI70	'O' Ring, NI70, 11.00mmID x 1.00mm CS	1
38	S10517	TI-C0360-026-1000-S	Spring, 9.14mm OD x 25.4mm lg	1
39	S11053	TI-3002-01-000	Motor Protector Valve Block Assembly	1
40	S10438	TI-3000-02-039	Impeller Seal Retainer	1
Nozzles	S10449 ^B	TI-3006-00-002	Super Zip Jet Jetting Nozzle	1
	S10452 ^B	TI-3006-00-005	Super Zip Jetting Nozzle T-Bar	1
	S10450	TI-3006-00-003	SZJ Suction Nozzle	1
	S10496	TI-89STR	SZJ/MSZ Pump Strainer (Blasted)	1
	S10488 ^B	TI-89620-M8	M8 SS Nyloc Nut	2
	S10492 ^B	TI-89710-M8	M8 SS Washer	2

^ANote: These parts are available as assembly part number S10560.

^BNote: These parts are available as assembly part number S10558.

*Note: S10441 and S10442 are supplied as a set and cannot be supplied individually.