

Micron Modem

Product Manual

0630-SOM-00001, Issue: 02



© Tritech International Ltd

The copyright in this document is the property of Tritech International Ltd. The document is supplied by Tritech International Ltd on the understanding that it may not be copied, used, or disclosed to others except as authorised in writing by Tritech International Ltd.

Tritech International Ltd reserves the right to change, modify and update designs and specifications as part of their ongoing product development programme.

All product names are trademarks of their respective companies.

Table of Contents

Help & Support	4
Warning Symbols	5
1. Introduction	6
2. Specification	7
2.1. Dimensions Diagram	7
2.2. Acoustic	7
2.3. Electrical and Communication	8
2.4. Physical	8
2.5. Pin-out Diagram & Cable Specification	8
3. Installation	9
3.1. Mounting	9
3.2. Handling	9
3.3. Power	10
3.4. Communication Protocol	10
3.5. Port Layout	10
3.6. Identifying the Slave and Master	11
4. Operation	12
4.1. Software	12
4.2. Integration Considerations	12
4.3. Transmission Characteristics	14
5. Configuration	15
5.1. Enabling Setup Mode	15
5.2. Modem Configuration Window	16
6. Maintenance	19
A. Testing with HyperTerminal or Docklight	20
B. CHIRP Signal Processing	25
Glossary	27

Help & Support

First please read this manual thoroughly (particularly the Troubleshooting section, if present). If a warranty is applicable, further details can be found in the Warranty Statement, 0080-STF-00139, available upon request.

Tritech International Ltd can be contacted as follows:

	Mail	<i>Tritech International Ltd</i> Peregrine Road Westhill Business Park Westhill, Aberdeenshire AB32 6JL, UK
	Telephone	++44(0)1224 744 111
	Fax	++44(0)1224 741 771
	Email	support@tritech.co.uk
	Website	www.tritech.co.uk

Prior to contacting *Tritech International Ltd* please ensure that the following is available:

1. The Serial Numbers of the product and any *Tritech International Ltd* equipment connected directly or indirectly to it.
2. Software or firmware revision numbers.
3. A clear fault description.
4. Details of any remedial action implemented.



Contamination

If the product has been used in a contaminated or hazardous environment you *must* de-contaminate the product and report any hazards *prior* to returning the unit for repair. *Under no circumstances should a product be returned that is contaminated with radioactive material.*

The name of the organisation which purchased the system is held on record at *Tritech International Ltd* and details of new software or hardware packages will be announced at regular intervals. This manual may not detail every aspect of operation and for the latest revision of the manual please refer to www.tritech.co.uk

Tritech International Ltd can only undertake to provide software support of systems loaded with the software in accordance with the instructions given in this manual. It is the customer's responsibility to ensure the compatibility of any other package they choose to use.

Warning Symbols

Throughout this manual the following symbols may be used where applicable to denote any particular hazards or areas which should be given special attention:



Note

This symbol highlights anything which would be of particular interest to the reader or provides extra information outside of the current topic.



Important

When this is shown there is potential to cause harm to the device due to static discharge. The components should not be handled without appropriate protection to prevent such a discharge occurring.



Caution

This highlights areas where extra care is needed to ensure that certain delicate components are not damaged.



Warning

DANGER OF INJURY TO SELF OR OTHERS

Where this symbol is present there is a serious risk of injury or loss of life. Care should be taken to follow the instructions correctly and also conduct a separate Risk Assessment prior to commencing work.

1. Introduction

The *Tritech International Ltd* Micron Data Modem provides a means of transferring data acoustically through water. Operation is point to point, between a pair of Micron Data Modems, at operational distances of up to 500m horizontally and 150m vertically at a data rate of 40 bits per second.

Devices are addressed through a serial electrical interface, which may be controlled directly from a personal computer with a simple teletype (half-duplex) terminal program.

Spread Spectrum Technology

The quality of acoustic data transmission in water using conventional single frequency systems suffers considerably from multi-path phenomena. Sound transmitted from the sending modem arrives at the receiving unit via the direct path, and via a series of secondary paths, due to reflections from the sea surface and sea bottom. This can often result in the loss or corruption of transmitted data.

In addition, conventional systems have poor immunity to the continuously varying background sea noise (such as wave noise).

Tritech Spread Spectrum technology however does not concentrate the acoustic energy in one waveband, but produces a transmission which is linearly varied between 20kHz and 24kHz (known as a CHIRP waveform). By correlating the received signals with the CHIRP waveform it is possible to achieve superior performance in challenging multi-path environments.

In addition, identification of a unique transmission signature allows signals to be detected in extremely noisy conditions, to the extent that communication is successful even when the signal to noise ratio is as low as -6dB. This means that data streams can be successfully detected which are considerably below the background noise level.

2. Specification

2.1. Dimensions Diagram

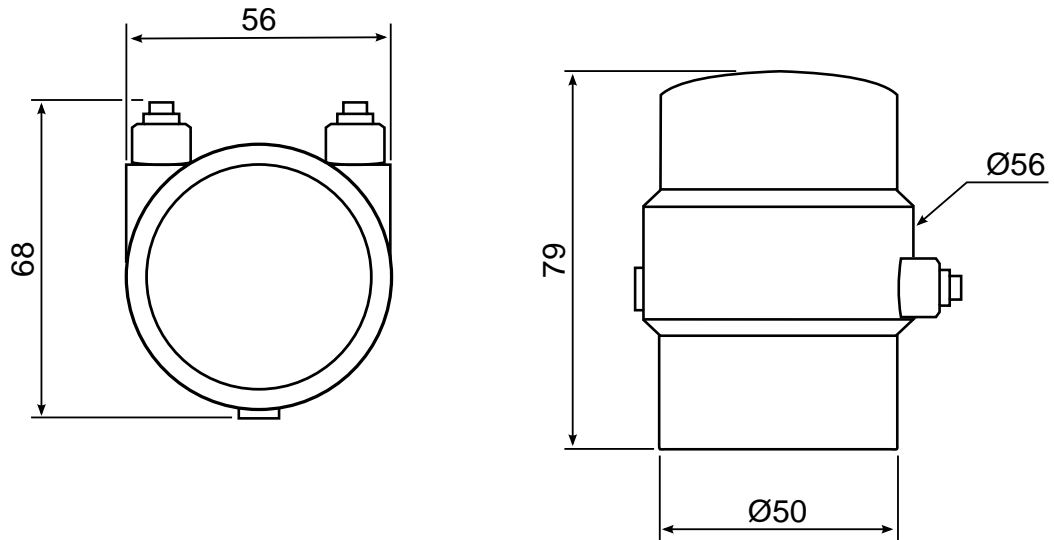

Not to scale, dimensions in mm.

2.2. Acoustic

Frequency band	20 - 28kHz
Data rate	40bit·s ⁻¹ (spread spectrum)
Range	500m horizontal, 150m vertical
Transmitter source	169dB re 1μPa at 1m
Doppler tolerance	±5m·s ⁻¹
Minimum signal to noise ratio	-6dB (in band)
Multipath rejection	Maximum delay spread of 10 - 100ms
Ranging	Integral range function with 0.1m resolution over full range and ±0.2m accuracy (assuming correct velocity of sound)

2.3. Electrical and Communication

Communications protocol	RS232 or RS485
Power supply	12 - 48V DC
Power consumption	7.92W (330mA at 24V) transmitting 0.72W (30mA at 24V) receiving

2.4. Physical

Weight in air	235g
Weight in water	80g
Depth rating	750m
Temperature range	-10 to 35°C (-20 to 50°C in storage)

2.5. Pin-out Diagram & Cable Specification



Caution

The Micron series connector is **not** wet mateable and direct exposure to water when the unit is powered will cause damage.

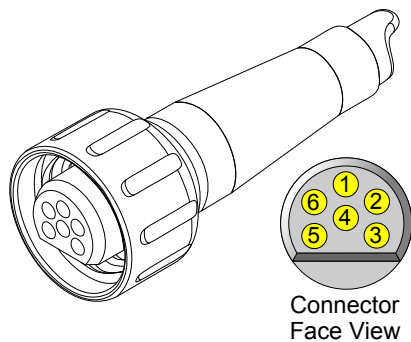

Pin	Wire Colour	Function
1	Yellow	RS485 A (-) RS232 TX
2	Blue	RS485 B (+) RS232 RX
3	Red	DC +
4	Black	DC ground
5	Green	RS232 ground
6	cable sheath	earth

3. Installation

3.1. Mounting

Orientation of the Micron Data Modem will normally be in the vertical position with the transducer uppermost. The transducer is omni-directional.

Four tapped holes in the aluminium body are provided by the bottom of the Micron Modem to permit mounting on flat surfaces, alternatively the Modem may be gently gripped by a 50mm diameter clamping mechanism around the bottom part of the housing.



Caution

It is recommended that any fixing screws used should be of a non-metallic material to reduce the risk of corrosion around the fixing positions.

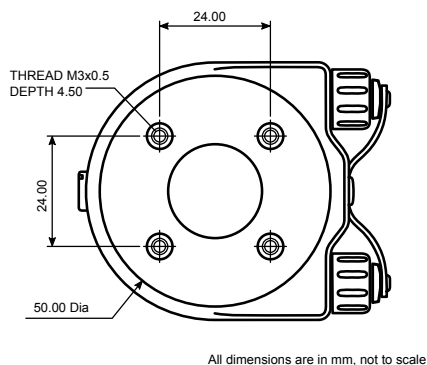

Figure 3.1. Mounting Holes on Micron Range

3.2. Handling

The Micron Data Modem is a sealed product and under no circumstances should it be opened or tampered with in any way. There are no user-serviceable parts or internal switches which would necessitate disassembly.

The connector socket is not usable "open face" and should always be sealed wither with a connector plug or the blanking plug provided. The auxiliary port should be blanked off at all times when not in use.

3.3. Power

The Micron Data Modem should be powered from a clean DC supply or battery pack. To reduce damage to the device in the event of over-voltage it is recommended that an appropriate fuse is included in the power supply connection.

For full details of the power requirement refer to Chapter 2, *Specification*.

3.4. Communication Protocol

The Micron Data Modem is supplied with two communications ports labelled `MAIN` and `AUX` (short for auxiliary). All communication to the control computer on the surface should be via the `MAIN` port.

The communication protocols used by the ports are factory set and are not user selectable other than at the time of build.

- The RS232 telemetry is bi-directional, 3-wire (TX, RX and ground) between the data modem and the controlling serial port.
- The RS485 telemetry is half-duplex, 2-wire (RS485+ and RS485-). Typically the controlling RS485 connection can be an RS485 serial port installed in a computer or can be an RS485 to RS232/USB signal converter. The RS485 circuit inside the Micron Modem is factory supplied with a 150Ω termination.

A pair of Micron Data Modems can be connected between two serial devices in order to transfer data between them acoustically.

For pin-out and cable specification refer to Chapter 2, *Specification*

3.5. Port Layout

The Micron Modem is supplied with two communications ports labelled `MAIN` and `AUX`. All communication to the control computer on the surface should be via the `MAIN` port, while the `AUX` port is used for daisy chained communication links to other *Tritech International Ltd* sensors, such as the Micron Echosounder.

The communication configuration of the ports are factory set. The factory setting is written on the label attached to the Micron, and can also be obtained from the original build record.

Any combination of protocols (RS232 and RS485 only) are possible and *Tritech International Ltd* use the letters A to D to denote the factory settings:

ID	MAIN	AUX	Label Example
A	RS485	RS485	
B	RS232	RS485	
C	RS485	RS232	
D	RS232	RS232	



Note

If the settings are changed through software it is important to keep a record of the changes, otherwise it can be difficult to re-connect to the modem.

3.6. Identifying the Slave and Master

When installing the unit it is important to know which device is the Surface Modem (or Master) and which is the Subsea Modem (or Slave). The product label on the underside of the unit will identify the unit as appropriate.

Checkbox	Function	Label Example
LP	The unit has been configured with a specialised Low Power mode. This is a non-standard mode of operation.	
SU	The unit has been configured as a Surface Modem.	
SS	The unit has been configured as a Subsea Modem.	
RS	The unit has been configured as a Responder for use with the MicronNav system. It will not be usable as a modem.	
XP	The unit has been configured as a Transponder for use with the MicronNav system. It will not be usable as a modem.	

4. Operation

4.1. Software

Tritech International Ltd does not supply the Micron Data Modem with specific operating software. Seonet Pro software is required should any modem re-configuration be required (refer to Chapter 5, *Configuration*).

Any terminal software may be used to operate and test a pair of data modems, however, they will normally be used as part of a larger system, the hardware of which will take control of the data transfer process

The Micron Data Modem is configured to communicate on RS232 at 9600Bd, 8 data bits, 1 stop bit and no parity by default. Other rate options are possible although the device is not configurable once in the field. If the settings of a particular device are unknown contact *Tritech International Ltd* Technical Support providing the serial number and any of the original purchase details (if known).

4.2. Integration Considerations

A pair of Micron Data Modems may be used in the following basic configuration:

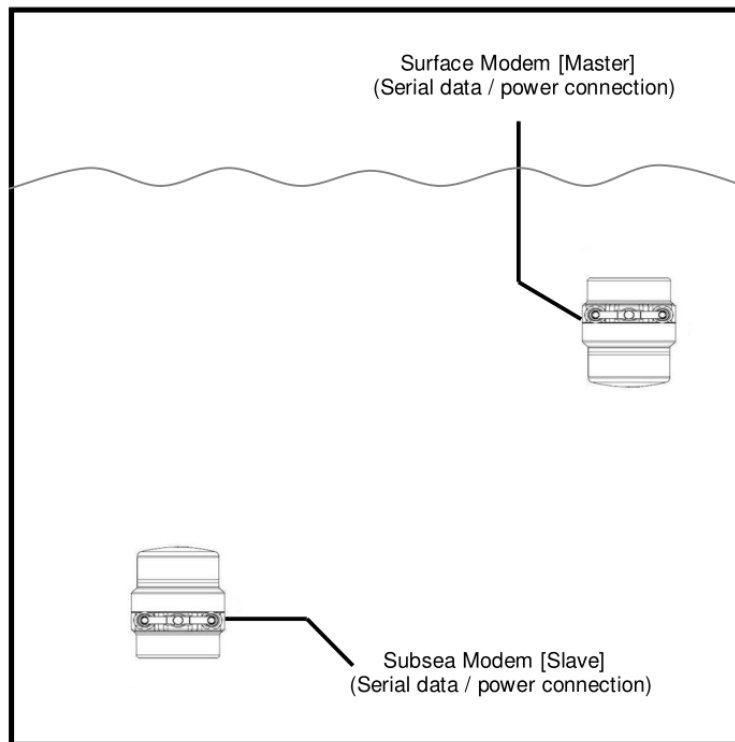

Figure 4.1. Pair of Micron Modems in Use

The following points should be noted:

- The terms "Master" and "Slave" in Figure 4.1, "Pair of Micron Modems in Use" are used purely as an aid to system description. Either unit can transmit to and receive from the second unit. The operating distinction between a master and slave is that each uses a separately coded CHIRP to avoid a unit receiving a close echo of its own transmission.
- The Micron Data Modem acoustic communication link provides a serial data transmission path through water.
- The Micron Data Modem has an internal buffer of 256 bytes. The incoming serial data rate must take into account of the acoustic transmission rate of $40\text{bit}\cdot\text{s}^{-1}$ and this buffer size.
- The acoustic radiation pattern is approximately omni-directional, and the modem will operate in both horizontal and vertical attitudes.
- Data modems should not be placed close to any acoustically reflecting surfaces, such as a boat hull or the sea/seabed surface, ideally providing a separation of at least 1m.
- Each Micron Modem is capable of withstanding Doppler shifts of up to $\pm 5\text{m}\cdot\text{s}^{-1}$.
- No unique addressing function is provided. A slave modem can communicate with a master modem only, with a master modem capable of broadcasting data to all slave modems within operational range.

- Data control is not provided by the Micron Data Modem. For instance simultaneous transmissions from both modems in a pair may not result in transmission receipt by either modem. Control of the Micron Modem must be handled by the connected computer or hardware.
- Error checking and data quality is not provided by the Micron Modem. Any error in transmission will not be detected by the Modem and the Modem will not attempt re-transmission of the same data should it not be received correctly by the receiving Modem.
- The RNG function command can be used to calculate the distance acoustically between the two Modems with a resolution of 0.1m and an accuracy of 0.2m

4.3. Transmission Characteristics

Transmission characteristics are depended on a variety of operating conditions which may significantly reduce operating range:

- The presence of thermoclines
- The presence of acoustically reflecting surfaces within the operating environment
- Ambient noise
- Salinity
- Volume reverberation
- Surface and seabed reflectivity
- Significant Doppler shifts present, due to the relative movement between two communicating Modems.

5. Configuration

5.1. Enabling Setup Mode

Ensure the Modem is powered off and the PC serial port connected to the Modem is enabled, set to a baud rate of 57600Bd

Launch Seanet Setup and navigate to Com Setup from the Utilities menu. In the dialog that is displayed make sure that the device Aif is enabled and using the correct COM port that is connected to the Micron Modem (the Status column should read Not Available until the Micron Modem is turned on).

Power on the modem while holding a magnet to the side of the housing as indicated in Figure 5.1, “Location of Reset Switch (activated by magnet)”.



Figure 5.1. Location of Reset Switch (activated by magnet)

Once the Micron Data Modem has started it will be listed as node number 85 in the Seanet Setup node table and should be labelled as MINIMODEM.

From here it is possible to select Setup from the Action column to enable the setup mode for the Micron Modem. This is illustrated in Figure 5.2, “Enter Micron Modem Setup”.

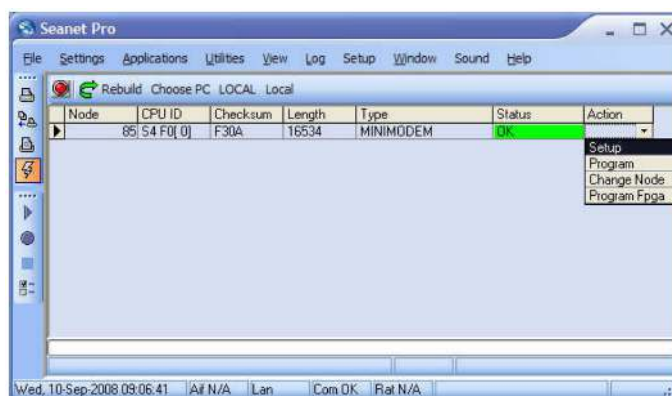

Figure 5.2. Enter Micron Modem Setup

5.2. Modem Configuration Window

From the node table in Seanet Setup select Setup from the action column of the row which shows the Micron Modem. This will bring up the AM100ModemCfgSetup dialog as shown in Figure 5.3, “Micron Modem Configuration”.

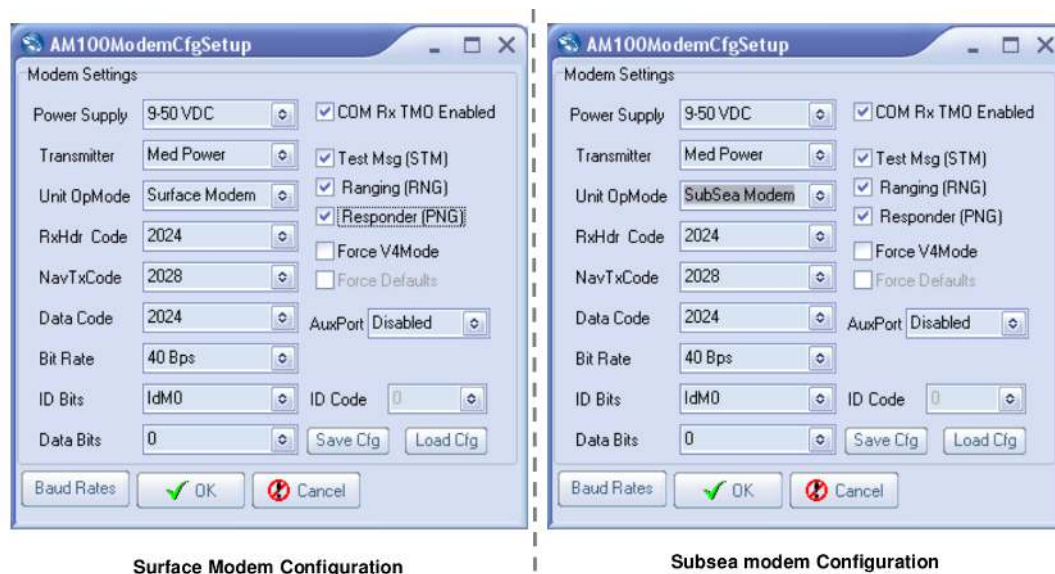

Figure 5.3. Micron Modem Configuration

The AM100ModemCfgSetup dialog allows the following settings to be changed:



Note

Test Msg, Ranging and Responder all must be entered in lower case characters followed by a line feed command and no carriage return terminator.

- Unit OpMode Select Surface Modem or SubSea Modem (Transponder and Responder are not applicable to the Micron Data Modem).
- COM Rx TMO Enabled This option should always be selected to prevent data loss.
- Test Msg (stm) When selected, on receipt of an `stm<LF>` string the receiving modem responds with the message: `Hello!!! This is a test message using spread spectrum at 40bps`
- Ranging (rng) When selected on receipt of an `rng<LF>` string the receiving modem responds with a transmitted

CHIRP allowing the first modem to calculate the total transmission time, and hence the intervening distance in metres. This is displayed as a range value between the two modems.

Responder (png) When selected on receipt of a png<LF> string, the receiving modem responds with an acoustic CHIRP - used for diagnostics only.

Force 4 Mode Forces Setup mode to be entered without using a magnet during power-up operation.

Save Cfg Saves the current set of settings to a configuration file.

Load Cfg Loads a set of settings from a configuration file.

Baud Rates



Caution

The Hi Speed 57600 setting in Async 0 (Serial LAN AUX 1) section must not be altered - the magnetic reset does not reset the baud rates).

This button will load the Comms Setup dialog. The only field that should be altered is indicated in Figure 5.4, “Comms Setup Dialog”.

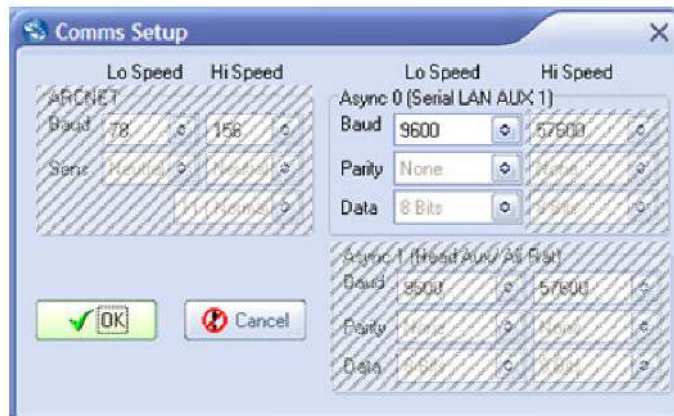

Figure 5.4. Comms Setup Dialog

To change the setting

1. Select the required baud rate from the list in the field indicated in Figure 5.4, “Comms Setup Dialog”.
2. Press OK on the Comms Setup dialog.
3. Press OK on the AM100ModemCfgSetup dialog and the changes made will be programmed into the modem.

**Note**

Any parameters not listed above are not effective at present and should not be selected or changed from the factory defaults.

6. Maintenance

There are no user serviceable components in the Micron Modem and there is no reason to dismantle the device.

Wash down with fresh water each time the Micron Modem is recovered from the water, paying particular attention to the transducer and connector.

Although the Micron Modem is designed for a wide temperature range it is best to avoid temperature extremes for long periods and protect the device from bright sunlight.

It is recommended that usage logs are maintained and that the heads are returned to the vendor at 4000 hour intervals for routine inspection and replacement of o-ring seals.

Any cables that are supplied with the Micron Modem are high quality with low halogen jackets and should provide long service life without problems. Care should be taken to ensure that they are properly sited during installation to avoid movement and fatigue but otherwise no maintenance is required.

Appendix A. Testing with HyperTerminal or Docklight

The Micron Data Modems can be bench tested in air using any terminal program. Typically the modems being tested should be no further than about 20-30cm apart with a clear line of sight present between the blue potted transducer on each modem. If the modems are too far apart in air then corruption of the ASCII message will occur or no data will be received by the second modem.

HyperTerminal

1. Open HyperTerminal (if this is installed, it will be located in the Windows Start Menu).
2. Enter the name for the Terminal window and then click OK:

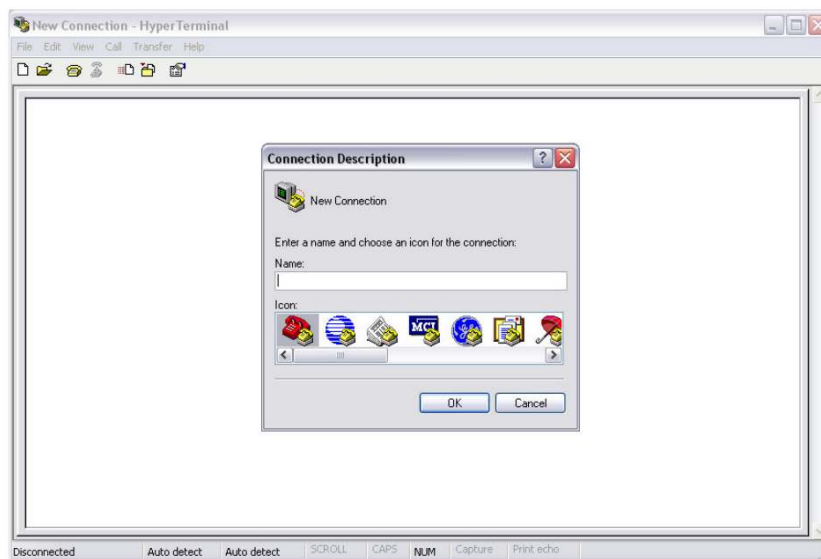

3. Next select the COM port number of the port that the first modem is connected to and click OK.



4. Ensure that the Bits per second (baud rate) is set correctly for the modem (9600 is default) and set the flow control to None.

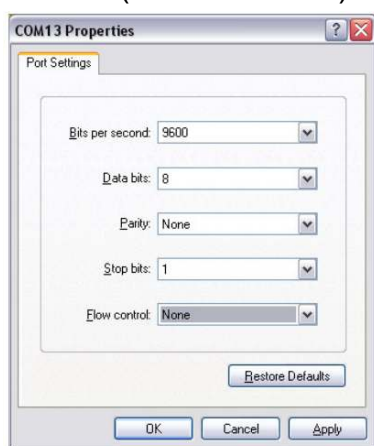

5. Within the main Terminal window click on the Call drop down menu and select Disconnect. Then click on the File drop down menu and select Properties. Click on the Settings tab at the top of the window and click the ASCII Setup button.

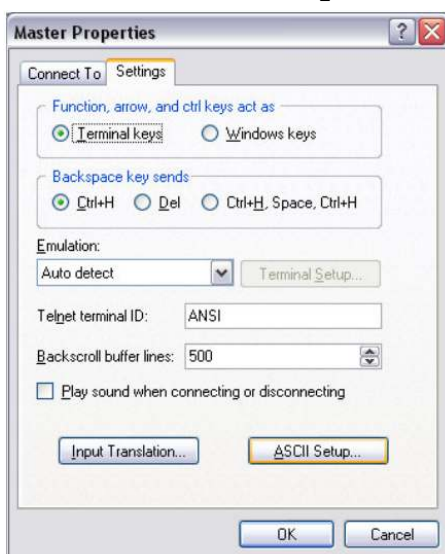

6. Ensure that the Send line ends with line feeds and Echo typed characters locally options are checked and click OK to apply the settings and then click OK on the properties dialog.

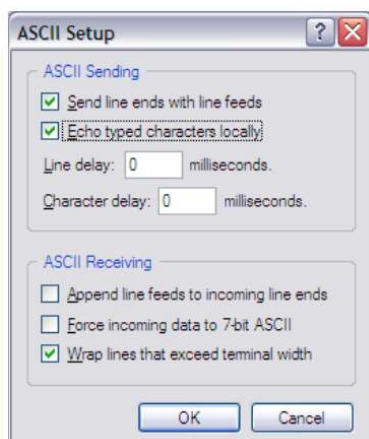

7. Repeat steps 1-6 to create another terminal window for the second modem.

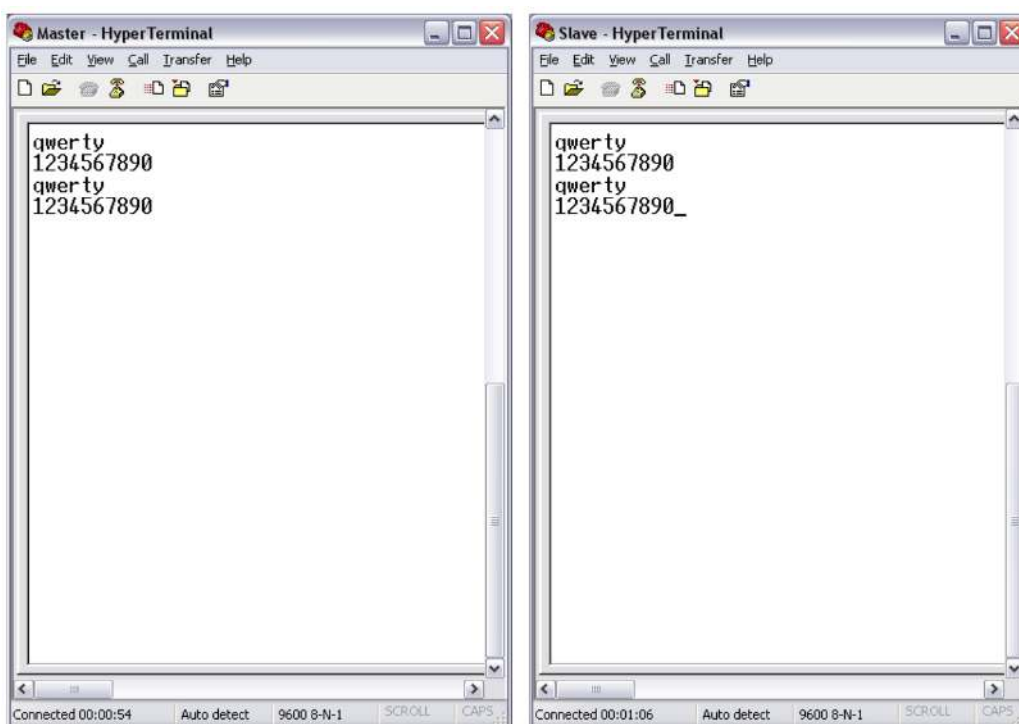

8. Using the mouse to click one terminal window into focus, any typed ASCII message will be transmitted acoustically from one modem to the second modem. With the Master/Slave modem configuration, multiple Slave modems can be connected and tested in HyperTerminal with one Master modem. The Master modem ASCII message is broadcast to all Slave modems in range and each Slave modem message is only received by the Master modem.

Docklight



Note

The version in use here is Docklight V1.9. Docklight is available from www.docklight.de.

1. Within the Send Sequences box double click on the grey box in the Name column to enter the Edit Send Sequence dialog.

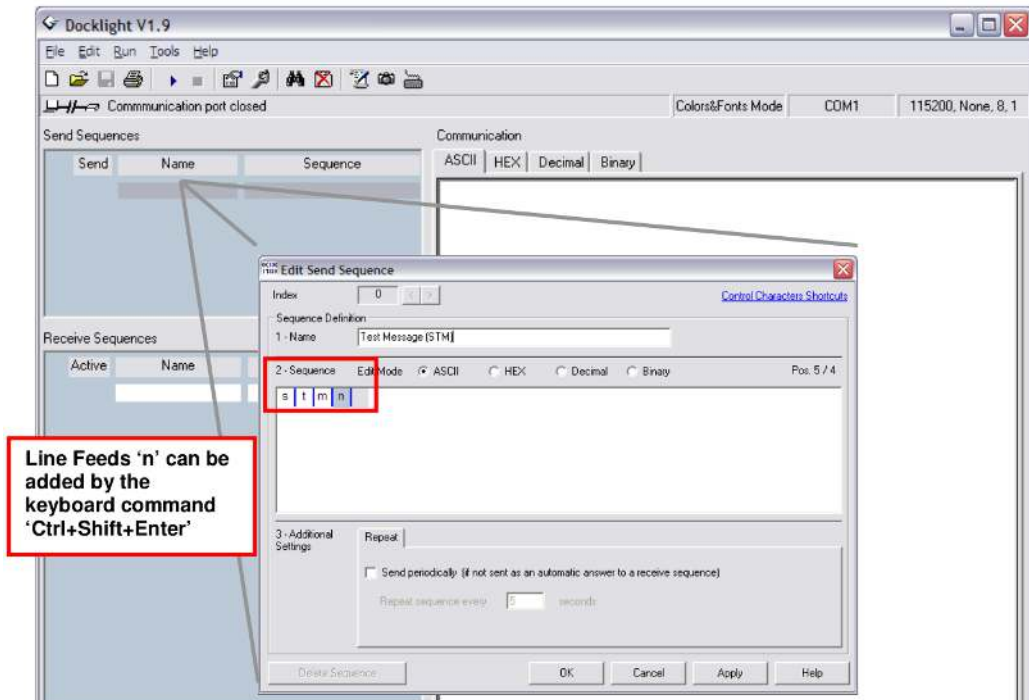

2. Next fill in the commands for Test Message, Ranging and Responder (clicking Apply after each command) and use the Index selection arrows at the top of the window to switch to the next command window and then click OK to add them. The main window should now be shown as below with the three function commands entered:



3. The COM port that the Micron Data Modem is attached to needs to be configured. Double click on the COM port number in the top right hand corner of the main window which will open the Project Settings dialog. Within this dialog select the appropriate COM port for the modem to be used. Ensure the baud rate is set to match the modem (9600 by default) and that the Send/Receive option is selected.

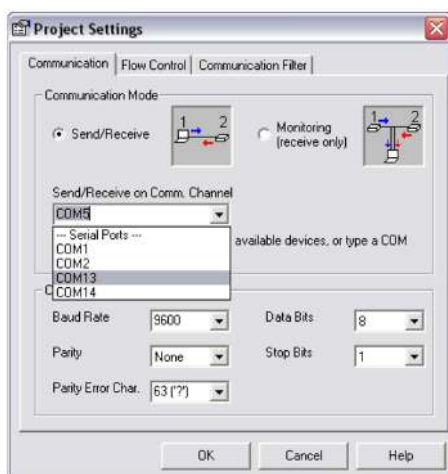

4. For testing the Micron Data Modem the COM port that the Master is connected to should be selected in Docklight first and used to send the function commands and check that the appropriate command response is received. Then the COM port that the Slave is connected to should be selected and the commands sent again. This will check that both modems can send and receive commands. An example output is shown:

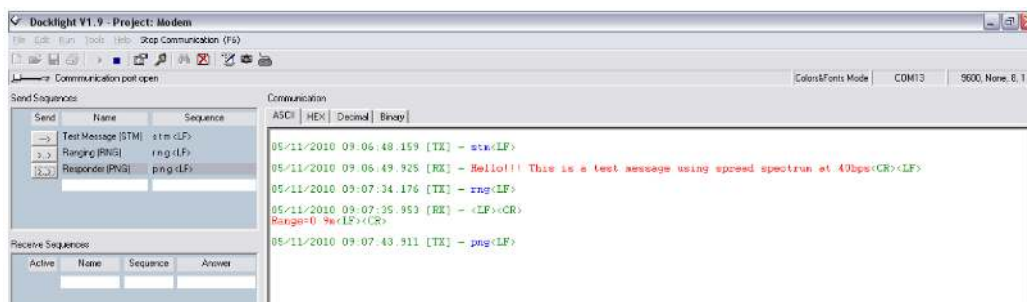

Appendix B. CHIRP Signal Processing

There are several advantages of *Tritech International Ltd* Digital Sonar Technology (DST) which allows the use of CHIRP signal processing technology in order to improve the images generated by the sonar.

In monotonic (single frequency burst) sonar, the range resolution is determined by the length of the transmitted pulse. The smaller the pulse is, the greater the resolution achievable and vice-versa. The smallest pulse length is typically 50 micro seconds and velocity of sound in water is approximately 1500 metres/second which gives a range resolution of 37.5mm. This result effectively determines the ability to resolve separate targets.

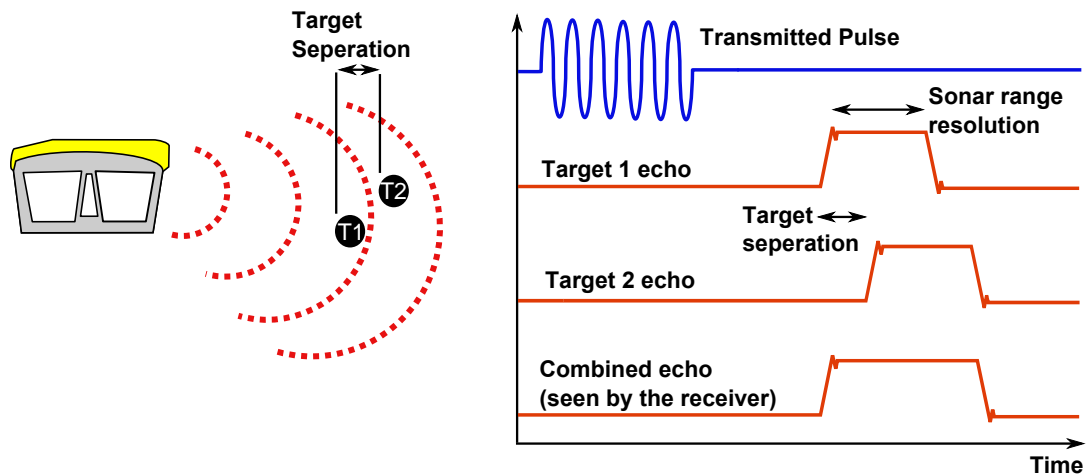

Using the example above, if two targets are less than 37.5mm apart then they cannot be distinguished from each other. The net effect is that the system will display a single large target, rather than multiple smaller targets.

CHIRP signal processing overcomes these limitations by sweeping the frequency within the burst over a broad range of frequencies throughout the duration of transmission pulse. This creates a signature acoustic pulse - the sonar knows what was transmitted and when. Using pattern-matching technology, it can now look for its own unique signature being echoed back from targets.

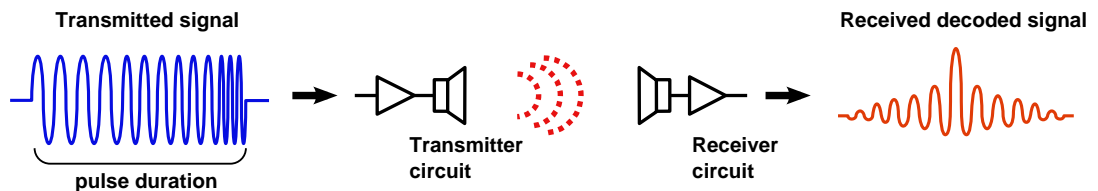

In a CHIRP system, the critical factor determining range resolution is now the bandwidth of the CHIRP pulse which means the range resolution is given by:

$$\text{Range resolution} = \frac{\text{velocity of sound}}{2 \times \text{bandwidth}}$$

The bandwidth of a typical *Tritech International Ltd* CHIRP system is 50kHz

With velocity of sound in water of 1500m/s this gives a new range resolution of 15mm.

This time, when two acoustic echoes overlap, the signature CHIRP pulses do not merge into a single return. The frequency at each point of the pulse is different, and the sonar is able to resolve the two targets independently.

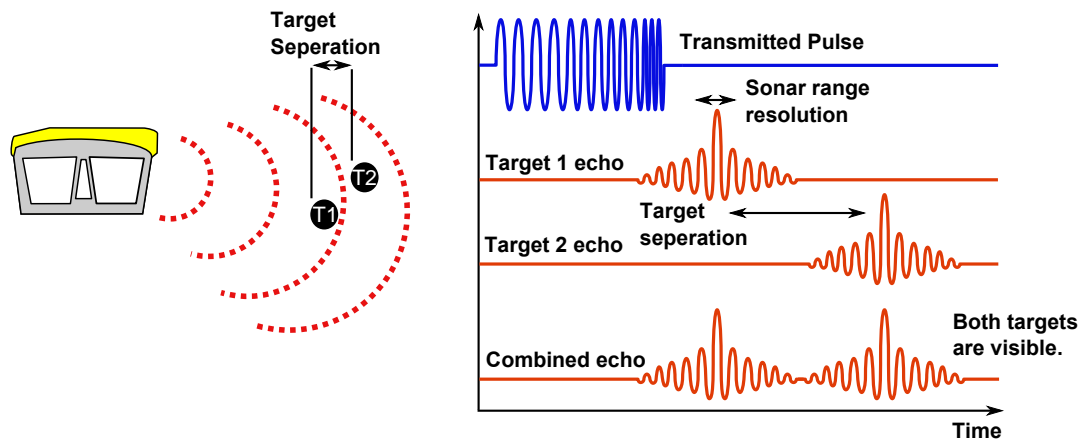

The response from the pattern-matching algorithms in the sonar means that the length of the acoustic pulse no longer affects the amplitude of the echo on the sonar display.

Longer transmissions (and operating ranges) can be achieved without a loss in range resolution.

Additionally CHIRP offers improvements in background noise rejection, as the sonar is only looking for a swept frequency echo, and removes random noise or out-of-band noise.

Glossary

ASCII	American Standard Code for Information Interchange - a character encoding scheme originally based on the English alphabet.
CHIRP	Compressed High Intensity Radar Pulse - a technology for improving image resolution initially used in radar systems but also adapted to sonar devices.
DC	Direct Current
RS232	Traditional name for a series of standards for serial binary data control signals.
RS485	A standard for defining the electrical characteristics of drivers and receivers for use in a balanced digital multipoint system (also known as EIA-485).
RX	Receive (data)
TX	Transmit (data)
USB	Universal Serial Bus.