

MicronNav System

Product Manual

0656-SOM-00001-07



© Trittech International Ltd

The copyright in this document is the property of Trittech International Ltd. The document is supplied by Trittech International Ltd on the understanding that it may not be copied, used, or disclosed to others except as authorised in writing by Trittech International Ltd.

Trittech International Ltd reserves the right to change, modify and update designs and specifications as part of their ongoing product development programme.

All product names are trademarks of their respective companies.

Table of Contents

Help & Support	5
Warning Symbols	6
1. Introduction	7
2. Technical Specification	8
2.1. System	8
2.2. Surface MicronNav100 Interface Hub	9
2.3. Surface USBL Dunking Transducer	10
2.4. Subsea Modem Head	11
3. Installing the System	12
3.1. Preparation	12
3.1.1. Using the system with the Micron INS	12
3.1.2. Mounting the Subsea Modem Head	12
3.1.3. Mounting the Surface USBL Dunking Transducer	13
3.1.4. Electrical Connections to the Subsea Modem Head	15
3.1.5. Electrical Connection to the Surface USBL Dunking Transducer	16
3.1.6. Electrical Connection to the Surface MicronNav100 Interface Hub	16
3.1.7. External Computer Data Link Electrical Connections	16
3.2. Installation	17
3.2.1. System requirements	17
3.2.2. Installing Seagnet Pro	17
3.2.3. Surface Hardware Installation and Configuration	19
3.2.4. Subsea Hardware Responder Configuration	21
3.2.5. Subsea Hardware Transponder Configuration	28
3.2.6. Connecting optional third party GPS Receiver	29
3.2.7. Connecting optional third party High Accuracy Heading/Pitch/Roll MRU Sensors	31
3.2.8. Data Input from an ROV	41
3.2.9. Connecting optional third party Video Camera	43
3.3. Remote Beacons	47
3.4. Dry System Check	50
3.4.1. Setting up the Application	50
3.4.2. Transducers and integral Heading/Pitch/Roll Sensor Check	50
3.4.3. Optional third party GPS Comms Check	52
3.4.4. Optional third party Heading & MRU Check	52
3.4.5. Optional third party Video Check	53
3.5. Hardware Reset	53
4. Operation	55
4.1. Mobilising the System	55
4.1.1. Pre Dive Checks	55
4.1.2. Deploying the USBL Head	55
4.1.3. Measuring the Installation Offsets	55
4.1.4. Creating a New Job (Using Wizard)	56
4.1.5. Editing an Existing Job	62
4.1.6. Loading an Old Job	63
4.1.7. Job Settings for Mobile or Fixed Platforms	64
4.1.8. Applying a Geodetic Datum Shift to the reference co-ordinates	70
4.1.9. Launching the Subsea Installation	77
4.2. Operating the System	78
4.2.1. User Controls	78
4.2.2. The Readings Explained	79
4.2.3. User Features	79
4.2.4. Other Controls	84
4.3. Logging and Replay	86
4.4. Shutting Down the System	86
5. Maintenance	87

6. Adding and Using User Bitmap Charts	88
6.1. Adding a Chart	88
6.2. Editing a Chart	90
6.3. Deleting a Chart	91
6.4. Chart controls	91
6.5. Markers	92
6.5.1. Overview	92
6.5.2. Creating and Laying a Marker	92
6.5.3. Saving the Markers	93
6.5.4. Loading the Markers	96
6.6. Other Chart Functions	96
6.7. Load BSB Charts	100
7. Using the External Computer Data Link	105
7.1. Setting the RemV4 string output	105
7.2. List of Current String Formats	108
7.2.1. Proc XYZ	109
7.2.2. Raw XYZ	111
7.2.3. TP-2EC	113
7.2.4. Simrad HPR 300P	114
7.2.5. Simrad HPR 410	115
7.2.6. NMEA \$RATTM	117
7.2.7. NMEA \$GPGGA	119
7.2.8. NMEA \$GPGLL	121
7.2.9. NMEA \$GPRMC	121
7.2.10. \$PSIMSSB	123
7.2.11. NMEA \$GPDBT	125
7.2.12. Notes	126
8. Using with Other Trittech Sonars	127
9. Adding a Micron Echosounder	128
10. Adding a Micron INS	130
11. Conversion Between MicronNav Responder and Transponder	131
11.1. Seonet Setup for Conversion	131
11.2. Conversion to Transponder	133
11.2.1. Enabling the USBL Transducer Transponder Transmitter	134
11.2.2. Configure Seonet Pro for Transponder Mode	134
11.3. Conversion to Responder	136
11.3.1. Connect the Micron Sonar and Responder	137
11.3.2. Configure Seonet Pro Responder Mode	139
Glossary	142

Help & Support

First please read this manual thoroughly (particularly the Troubleshooting section, if present). If a warranty is applicable, further details can be found in the Warranty Statement, 0080-STF-00139, available upon request.

Tritech International Ltd can be contacted as follows:

	Mail	<i>Tritech International Ltd</i> Peregrine Road Westhill Business Park Westhill, Aberdeenshire AB32 6JL, UK
	Telephone	++44(0)1224 744 111
	Fax	++44(0)1224 741 771
	Email	support@tritech.co.uk
	Website	www.tritech.co.uk

Prior to contacting *Tritech International Ltd* please ensure that the following is available:

1. The Serial Numbers of the product and any *Tritech International Ltd* equipment connected directly or indirectly to it.
2. Software or firmware revision numbers.
3. A clear fault description.
4. Details of any remedial action implemented.



Contamination

If the product has been used in a contaminated or hazardous environment you *must* de-contaminate the product and report any hazards *prior* to returning the unit for repair. *Under no circumstances should a product be returned that is contaminated with radioactive material.*

The name of the organisation which purchased the system is held on record at *Tritech International Ltd* and details of new software or hardware packages will be announced at regular intervals. This manual may not detail every aspect of operation and for the latest revision of the manual please refer to www.tritech.co.uk

Tritech International Ltd can only undertake to provide software support of systems loaded with the software in accordance with the instructions given in this manual. It is the customer's responsibility to ensure the compatibility of any other package they choose to use.

Warning Symbols

Throughout this manual the following symbols may be used where applicable to denote any particular hazards or areas which should be given special attention:



Note

This symbol highlights anything which would be of particular interest to the reader or provides extra information outside of the current topic.



Important

When this is shown there is potential to cause harm to the device due to static discharge. The components should not be handled without appropriate protection to prevent such a discharge occurring.



Caution

This highlights areas where extra care is needed to ensure that certain delicate components are not damaged.



Warning

DANGER OF INJURY TO SELF OR OTHERS

Where this symbol is present there is a serious risk of injury or loss of life. Care should be taken to follow the instructions correctly and also conduct a separate Risk Assessment prior to commencing work.

1. Introduction

The Tritech MicronNav system is an innovative Ultra Short Base Line (USBL) acoustic tracking system designed for tracking or marking the position of underwater vehicles or objects. The design of the system provides 180° hemispherical coverage from the surface unit and 360° omni-directional coverage from the subsea unit enabling continuous reliable tracking even in very shallow water. The size of the subsea unit is small enough to be fitted to the smallest of observation class vehicles.

The system can be used stand-alone in Transponder mode in which case the subsea unit only requires power, or it can be used with Tritech's range of imaging Sonars (Micron MKII or MKIII, Super SeaKing and Gemini) in responder mode in which case the subsea unit is powered by and communicated with through the Sonar Aux port. It is synchronised with the Sonar to reduce the effect of acoustic interference on the sonar display. For compatibility with other *Tritech International Ltd* Sonars see Chapter 8, *Using with Other Tritech Sonars*

The MicronNav system consists of a Seanet Pro application software package for installation onto a suitable PC or laptop computer, a small surface MicronNav100 Interface Hub, a lightweight surface USBL 'Dunking' Transducer (with integral magnetic compass and pitch/roll sensor) and one or more small subsea MicronNav Modem heads.



Note

The Tritech SeaHub Surface Interface Module cannot be used in place of the MicronNav100 Hub.

The Seanet Pro application software running on a PC or Laptop commands the subsea MicronNav Modem head to transmit an acoustic ranging signal to the Surface USBL Dunking Transducer. When operating in stand-alone Transponder mode this command is sent acoustically via the USBL Dunking Transducer, and when combined with the Tritech sonar and operating in Responder mode this command is sent electronically via the sonar communications link.

The MicronNav acoustic ranging signal is detected by the USBL Dunking Transducer and MicronNav100 Hub Interface module and the received signal information sent to the host Seanet computer for calculation of range and bearing of the subsea head. USBL Dunking Transducer pitch/roll and heading data from the integral pitch/roll sensors and magnetic compass are also captured and sent to Seanet Pro for calculation of corrected position to world axis.

If GPS positional data is available the range and bearing of the subsea head is synchronised and the Seanet display updated with ships position and ROV position to true world position. Provision is made to allow position information to be overlaid onto a user supplied bitmap chart display of the local area if required.

The position fixing cycle is repeated dependent upon the selected update rate (0.5 – 10s).

2. Technical Specification

2.1. System

Positioning Technology	Spread Spectrum Acoustic Ultra Short Baseline (USBL) Range/Bearing Tracking System. 20-28 kHz band. (Magnetic Compass and Pitch/Roll Sensor built into Dunking transducer as standard)
Tracking Range	500m (1,640ft) typical Horizontal, 150m (492ft) typical Vertical. Range is dependent on a variety of operating conditions: <ul style="list-style-type: none"> • The presence of thermoclines • The presence of acoustically reflecting surfaces within the operating environment • Ambient noise • Salinity • Volume reverberation • Surface and seabed reflectivity
Range Accuracy	+0.2 metre (7.87 inches) system timing accuracy – assuming correct Velocity of Sound.
Bearing Accuracy	+/-3 degrees (equates to better than +5% of slant range)
Position Update Rate	0.5 Seconds – 10 Seconds
Targets Tracked	Maximum 1 Responder and 15 Transponders
Data Display	Plan Position Indicator (PPI) display and optional user bitmap chart display
Data Recording	All Data recorded in standard Seanet Format for Replay or Analysis
Surface Navigation	NMEA 0183 GPS and Heading/Attitude Sensors supported. Position of Surface vehicle displayable.

2.2. Surface MicronNav100 Interface Hub

AC Power Supply	90V to 264V, 47Hz to 63Hz. IEC-320 C14 socket (for C13 cord), 20x5mm 2A Antisurge (T) fuse
DC Power Supply	12V to 36V, 2.1mm (0.08") pin (positive centre).
Power Consumption	4.8W from either source (with no external load)
DC Power Output (Port D & AIF Port)	50W or 2A maximum current draw Internal 20mm x 5mm 2A Quick Acting (F) fuse. +33V if using AC, 1.5V less than the supply voltage if using DC. Defaults to highest voltage if both are connected.
Supported Protocols	USB2.0, RS232, RS422, RS485, ARCNET LAN.
Ports A, B and C	DE-9 male connectors RS232 (3 wire), RS485 (half duplex) on Ports A, B, C RS232 (5 wire – RTS, CTD) on Port A RS422 (full duplex differential) on Port B ARCNET differential (analogue) LAN on Port C
Port D	DIN-45322 Female Socket, screened with power & earth. RS232 (3 wire), RS485 (half duplex) ARCNET differential (analogue) LAN
AIF (ARCNET) Port	DA-15 female connector ARCNET differential (analogue) LAN ARCNET TTL LAN (for backplane connection) Optional support for "Port A" serial signals Power output available
USB 2.0 480Mbps Ports	One Type B on rear for PC connection. Two Type A ports on front for auxiliary devices. 500mA over-current protected +5V on front ports. Avoid USB hubs and cables exceeding 5m.
RAT Connection	A single DE-9 female front panel connector for connection to a "V2" Remote Access Terminal.
Transducer Connection	DB-25 female port on rear panel for connecting the MicronNav USBL Dunking Transducer.
Status Indicators	1 x Power/Status Indicator 4 x Communication Status Indicators (Red/Green) 11 x Communication Hardware Mode Indicators (Blue)
Dimensions	Width: 232mm, Height: 52mm, Depth: 185mm
Weight	1.3Kg
Material	Painted Aluminium, Matte Anthracite Textured Finish
IP Rating	IP20 (no protection against water ingress).
Temperature Limits	-10°C to 35°C (operation), -20°C to 50°C (storage)

2.3. Surface USBL Dunking Transducer

Operating Beamwidth	180 degrees
Power requirement	No external requirement – is supplied directly from MicronNav100 Interface Hub
Comms requirement	No external requirement – is connected directly to MicronNav100 Interface Hub
Frequency of operation	20-28kHz Spread Spectrum
Depth Rating	10metres (32.8 feet)
Cable Length	standard 10metres (32.8 feet) - other options available on request
Maximum Cable Length	50metres (164 feet)
Maximum Diameter	110mm (4.33 inches) including mounting plate
Body Tube Diameter	75mm (2.95 inches)
Maximum Height	270mm (10.63 inches)
Weight in Air	1.96kg (3lbs 15oz)
Weight in Water	810g (1lb 12oz)
Material	Mounting Flange: Marine Brass Housing: Grey ABS Transducer: Polyurethane
Operating Temperature	-10°C to +35°C
Storage Temperature	-20°C to +50°C

2.4. Subsea Modem Head

Operating Beamwidth	Omni directional Transducer
Power Requirement	12-48V DC Note: Reverse and over-voltage protection are not provided to the power supply.
Frequency	20-28kHz Spread Spectrum
Power Consumption	Dependent on the system interrogation rate which is user controlled (0.5, 1, 2, 5 or 10sec) for example at 1sec update the average power consumption would be 175mW typical and at 0.5sec would be 350mW typical.
Main Port Type	factory set to RS232 Note: Transient and over-voltage protection is applied to the Comms ports but Comms ports are not DC isolated.
Main Port data rate	factory set to 9600 baud (others available on request)
Aux Port Type	factory set to RS232
Aux Port data rate	factory set to 9600 baud (others available on request)
Depth Rating	750m (2,460ft)
Maximum Diameter	56mm (2.20 inches)
Maximum Height	76mm (2.99 inches)
Fixing Points	4 off M3 x 0.5 Tap 5.0 full thread
Weight in Air	210g (7.4oz)
Weight in Water	55g (1.9oz)
Material	Housing: Anodised Aluminium Transducer: Polyurethane
Operating Temperature	-10°C to +40°C
Storage Temperature	-20°C to +50°C



Caution

This specification refers to the Micron Nav Modem. The Micron Range (Sonar/ Seasprite, Echosounder, Micron Nav Modem) work on a voltage range of 12-48V DC with the exception of the Micron Data Modem which uses 12-24V DC. If you are unsure which product you are using either opt for a lower voltage or contact *Tritech International Ltd* to discuss product options.

3. Installing the System

3.1. Preparation

This section is intended to provide the user with sufficient information to allow for the consideration and preparation of mounting brackets and wiring arrangements prior to receipt of the system, final wiring however can only be completed once in receipt of the system as interconnect leads are supplied with the system.

3.1.1. Using the system with the Micron INS

The Trittech Micron INS has been designed to be fully compatible with the MicronNav System and can be integrated in a variety of ways.

For full details of how to install a Trittech Micron INS with the MicronNav please refer to the Micron INS Product Manual (document reference: 0722-SOM-00001) alongside this document.

3.1.2. Mounting the Subsea Modem Head

The Subsea Modem Head should be mounted at the top of the ROV ensuring the transducer is proud of the ROV fairing with a clear view from the transducer to the surface, also remembering to ensure enough room is left to enable the cable connection to be made to the Micron connectors. To assist with the mounting there are 4 off M3 x 0.5 tapped 5.0 deep full thread fixing holes in the base of the unit (note: these are protected with plastic grub screws when shipped from the factory and should be removed prior to using). An alternative method of mounting the head is to gently grip with a 50mm diameter clamping mechanism around the bottom part of the housing (in this case the plastic grub screws fitted to the fixing holes should be left in place).



Caution

It is recommended that any fixing screws used should be of non-metallic material to reduce the risk of corrosion around the fixing positions.

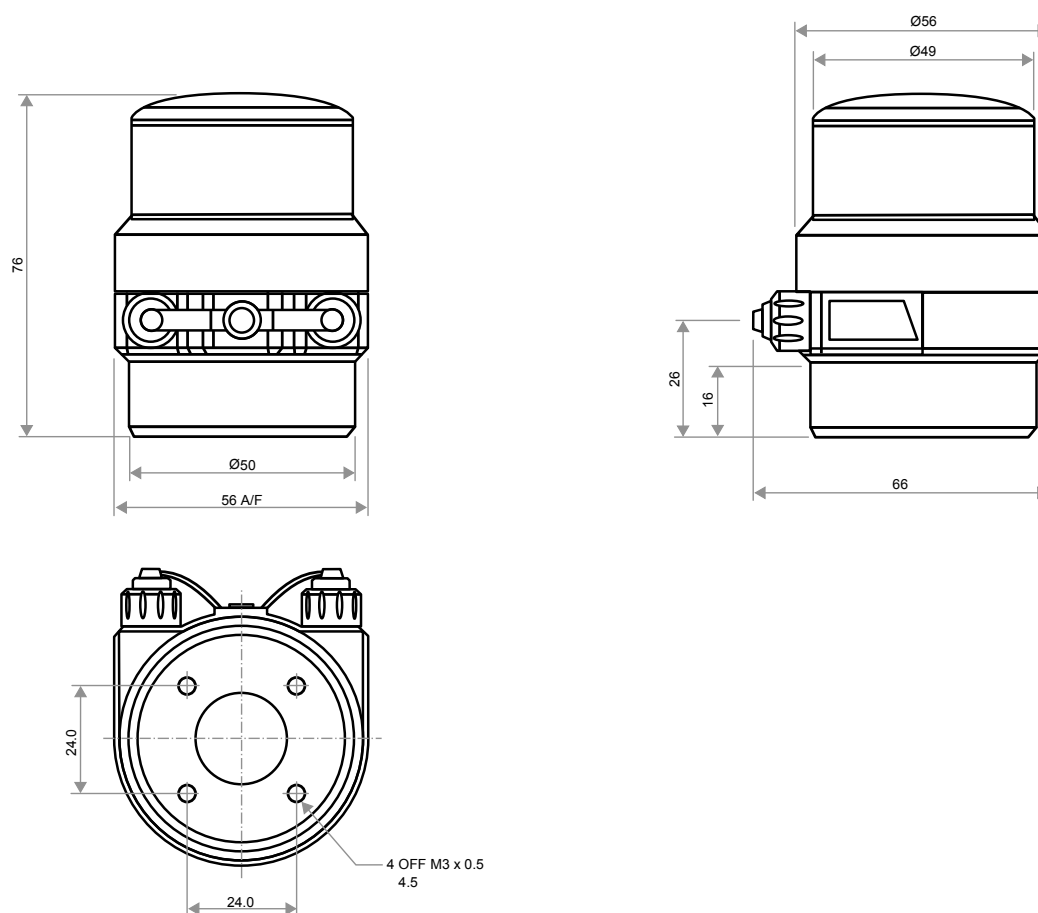

3.1.3. Mounting the Surface USBL Dunking Transducer

The USBL Dunking Transducer should be mounted from the fixed platform/dockside or mobile platform/vessel such that the transducer head is at least 1m to 2m below the surface of the water and at least 1m to 2m away from the dock wall or vessel, if operating from a vessel it may be difficult to achieve 1m to 2m clearance from the side so in this case lower the head deeper to ensure a clearance of 1m to 2m below the bottom of the hull.



Caution

The depth of the head must not exceed 10m. Also, when installing on a vessel it is important to ensure the head is mounted clear of any propellers or thrusters.

The USBL Dunking Transducer contains an integral Magnetic Heading and Pitch/Roll Sensor that enables the MicronNav Seaset application software running on the surface computer to make corrections to world axis, this is particularly effective when operating from a non-magnetic mobile platform/vessel or fixed dockside.

When operating from a steel hull vessel the integral sensor will be affected by magnetic interference from the vessel and it is recommended in this type of installation that an external Ships Compass & Motion Reference Unit (MRU) is used to provide the Heading and Pitch/Roll information, details of how to connect and use an external Compass & MRU sensor can be found in Section 3.2.7, "Connecting optional third party High Accuracy Heading/Pitch/Roll MRU Sensors".

The USBL Dunking Transducer is supplied with a short mounting pole (0.5m long) that will screw into the 22mm diameter coupling on the top of the USBL Head mounting flange and provide a clamping point for attaching to the users installation. The mounting flange coupling is a standard 22mm water pipe fitting (UK) enabling a standard 22mm diameter copper water pipe to be used as a mounting pole fitting directly to the head.

An alternative method of mounting the head is to fabricate a dedicated mounting bracket and fasten to the USBL mounting flange. It is recommended however that a non-magnetic material is used for the fixing so as not to affect the integral Magnetic Heading and Pitch/Roll sensor, if the user wishes to use stainless steel for the fabrication some Duplex Alloys such as FerraliumSD40 are particularly good but are rather exotic, stainless steel 316 (typical material used for sub-sea housings) however has little effect on the compass readings and could be used as an alternative.



Caution

When operating from a vessel consideration should be given to the speed the vessel is likely to be travelling and the resultant force/pressure the USBL Dunking Transducer mounting arrangement will need to withstand.

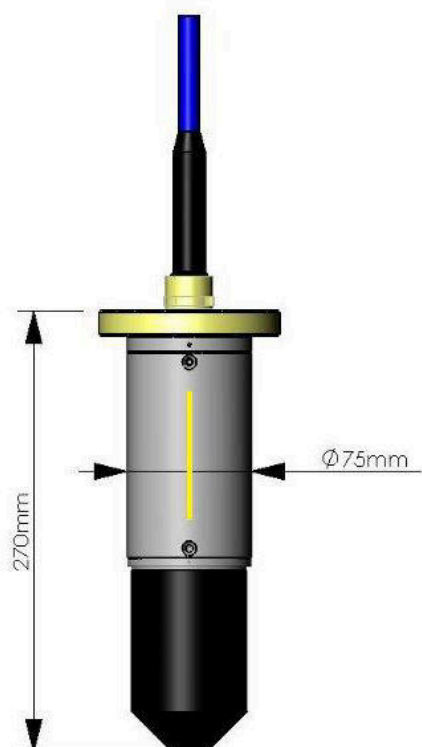

The yellow line indicates the front of transducer head. This should be positioned facing in the required forward position to ensure correct representation on the PPI display when set to "Ships Head Up". If operating from a fixed platform/dockside this would normally be facing away from the platform/dockside and if operating from a mobile platform this would normally align with the front of the vessel.

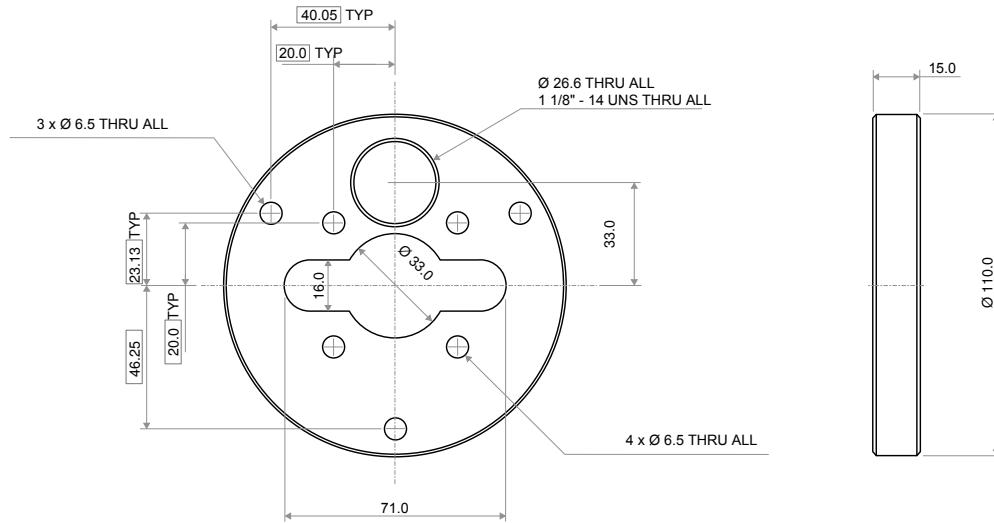

3.1.4. Electrical Connections to the Subsea Modem Head

Responder Mode

In Responder mode there is no direct connection from the ROV to the sub-sea Modem head - in this configuration the ROV connects to the Tritech Sonar head (Main port) using the cable supplied with the Sonar, and the MicronNav sub-sea Modem head (Main port) connects to the (Auxiliary port) of the Sonar using the Double Ended Interconnect cable supplied with the MicronNav system.

Transponder Mode

In Transponder mode the MicronNav subsea Modem head only requires power supply connections - this can be from the ROV, a stand-alone underwater battery pack or from the Auxiliary port of any of the Tritech subsea heads.

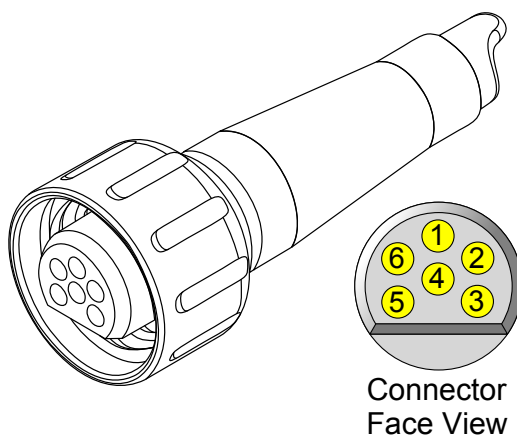

Pin	Wire Colour	Function
1	Yellow	not connected
2	Blue	not connected
3	Red	Supply +
4	Black	Supply Ground
5	Green	not connected
6	cable sheath	Earth/Screen

3.1.5. Electrical Connection to the Surface USBL Dunking Transducer

The USBL Dunking Transducer is supplied complete with underwater cable moulded directly onto the head and a DB-25 connector at the dry side for connection directly into the USBL connector on the rear of the MicronNav100 Interface Hub.

3.1.6. Electrical Connection to the Surface MicronNav100 Interface Hub

The surface MicronNav100 Interface Hub requires power from a 90 to 264V AC supply 47 to 63Hz, or a 12 to 36V DC supply - power consumption from either source will be typically 4.8W (with no additional external device load).

Communications from the MicronNav100 Interface Hub to the Subsea head (if being used with Micron/SeaSprite Sonar) is via a DE-9 socket which connects to *Port B* plug on the rear of the unit.

Connections to the DE-9 socket on *Port B* are as follows:-

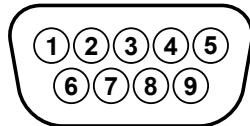

Pin	RS232	RS422	RS485
1	⚡	⚡	⚡
2	RX	TX.A	TX/RX.A
3	TX	TX.B	TX/RX.B
4	⚡	⚡	⚡
5	GROUND	GROUND	GROUND
6	⚡	⚡	⚡
7	⚡	RX.B	⚡
8	⚡	RX.A	⚡
9	⚡	⚡	⚡
<i>⚡ = connected for handshaking only.</i>			

Communications from the MicronNav100 Interface Hub to the computer running the MicronNav Seanet application software is via a USB Type-A to Type-B cable supplied with the system, connection is to the rear of the unit.

3.1.7. External Computer Data Link Electrical Connections

If the MicronNav data is required by a third party software package running on an external PC then connection from the Surface MicronNav100 Interface Hub to the external PC is made via one of the four serial interface connectors located at the rear of the unit, Port A, B, C or D. (Note: If the system is being used in Responder mode Port B will be used for the Sonar communications and will not be available for this).

If ports A, B or C are to be used for external communications a DE-9 socket should be wired as above, if port D socket is to be used a DIN-45322 (6 pin) plug is required and should be wired as follows:

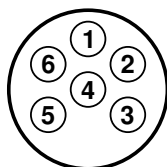

Pin	RS232	RS485
1	RX	TX/RX-A
2	TX	TX/RX-B
3	‡	‡
4	‡	‡
5	GROUND	GROUND
6	‡	‡

‡ = connected for handshaking only.



Warning

The 6 pin DIN-45322 connector Port D has a live 24V supply output on pin 3 referenced to 0V on pin 4.

3.2. Installation

3.2.1. System requirements

Seanet Pro has the following system requirements:

	Minimum	Recommended
Processor	2GHz	2GHz dual core
RAM	1GB	2GB
Graphics	3D hardware accelerated graphics card.	
Display	1280x1024 (32bit colour)	1600x1200 (32bit colour)
Disk space	Install is 20MB, greater than 160GB recommended for log files	
Networking	100Mbit·s ⁻¹ (fast Ethernet)	1000Mbit·s ⁻¹ (Gigabit Ethernet)
Software	Windows XP 32bit	Windows 7 32 or 64bit

It is highly recommended that your system specifications are checked against these requirements prior to attempting installation of Seanet Pro.

3.2.2. Installing Seanet Pro

Seanet Pro is supplied on a CD-ROM which has been designed to auto-run upon disc insertion. The latest commercial release of software is always available from www.tritech.co.uk.

Once loaded, the main menu of the CD will be shown on screen.

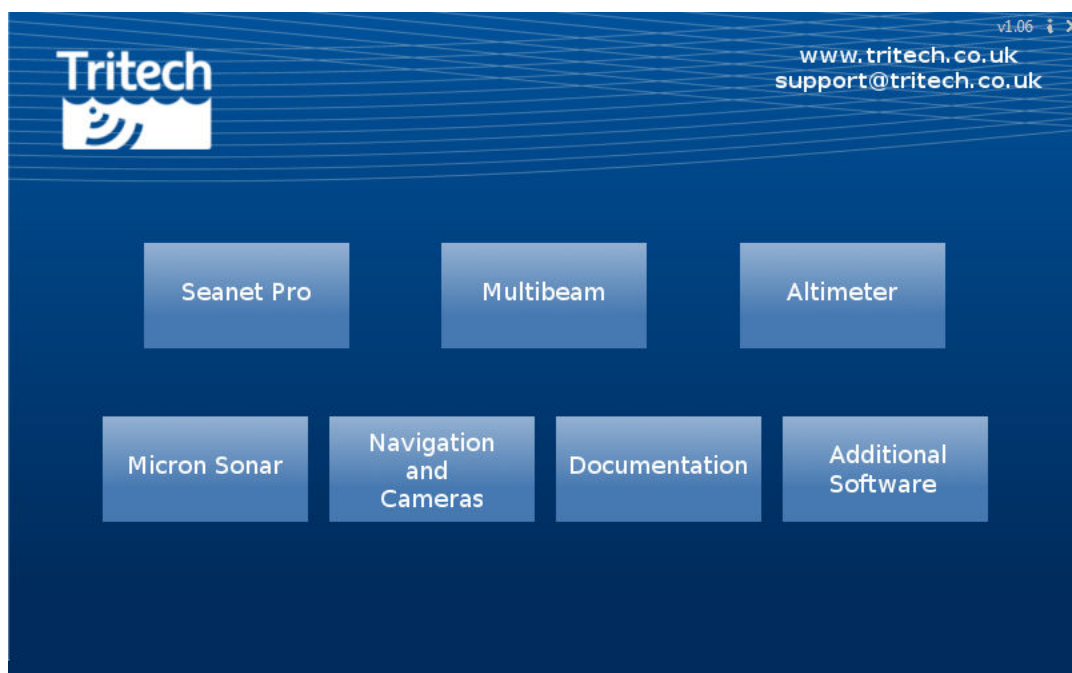

Click on the `Seanet Pro` button and the following screen will display all the appropriate software packages for installation.

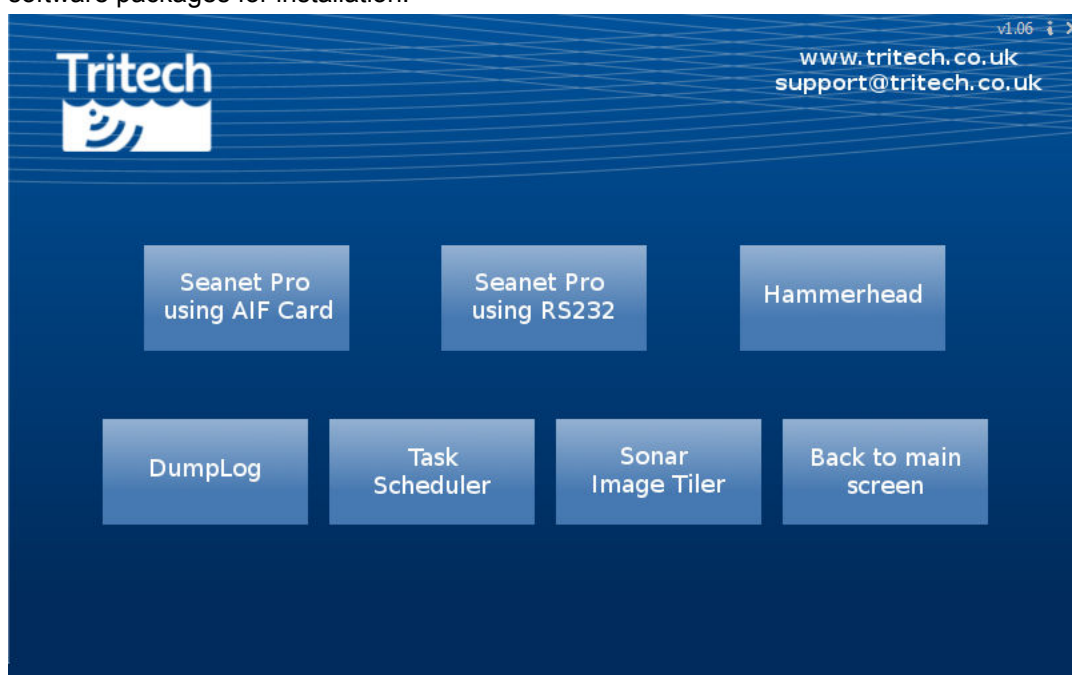

Click on the appropriate installation option and then follow the onscreen prompts and instructions.

- `Seanet Pro using AIF Card` - select this option if you are using a SCUv4, or PC equipped with a PCI AIF card.
- `Seanet Pro using RS232` - select this option if you are using a SeaHub, MicronNav Hub, PC or Laptop with either hardware COM Ports or USB converters.
- `Hammerhead` - this option installs a modified version for use with the Super SeaKing Hammerhead sonar.
- `Dumplog` - this option installs an additional software package for post-processing data files.

- `Task Scheduler` - this option installs an additional software package to automate the recording of logfiles with Seanet Pro.
- `Sonar Image Tiler` - this option installs an additional software package that can mosaic sonar imagery from Seanet Pro onto background images.



Note

Do not attempt to remove the CD-ROM from your computer during the installation process.

3.2.3. Surface Hardware Installation and Configuration



Caution

The power should be turned off before making a connection between the sonar head and surface controller (SCU or SeaHub).

Carefully unpack the system from the transit case and uncoil the USBL cable, the MicronNav100 Hub is located underneath the lift out section containing the Subsea Modem Head and cable assemblies.

If the supplied mounting pole is to be utilised fit it to the standard plumbing fitting on the brass mounting plate on top of the USBL Head and connect the USBL Head cable connector to the DB-25 socket on the rear panel of the MicronNav100 Hub.



Note

It is recommended to wait until after the system has been fully configured and the Dry System check completed before fitting the USBL Dunking Transducer to the desired mounting arrangement.

Connect the computer USB port on the rear panel of the MicronNav100 Hub to a USB 2.0 port on the User computer with the supplied USB cable assembly.

Connect power to the MicronNav100 Hub and switch on. The indicator LEDs on the front of the unit will flash and the ports will auto-install on the computer - this will take a minute or so to complete and you may be prompted to re-boot the computer.

The Seanet software must now be configured for the MicronNav100 Hub – click the `Seanet Setup` icon on the desktop to run the Seanet setup program, select `Utilities` from the top menu bar of the Seanet Setup window followed by `Com Setup` from the sub-menu to open the `Channel Setup` page, a dialog box will be opened notifying detection of the SeaHub on one of the COM ports and you will be asked to confirm Auto Enable of an Aif device - this should be confirmed by selecting YES. The Channel Setup page will then automatically add and enable the ports that are required as shown below.



Note

Port numbers may differ on different computers dependent on Windows setup.

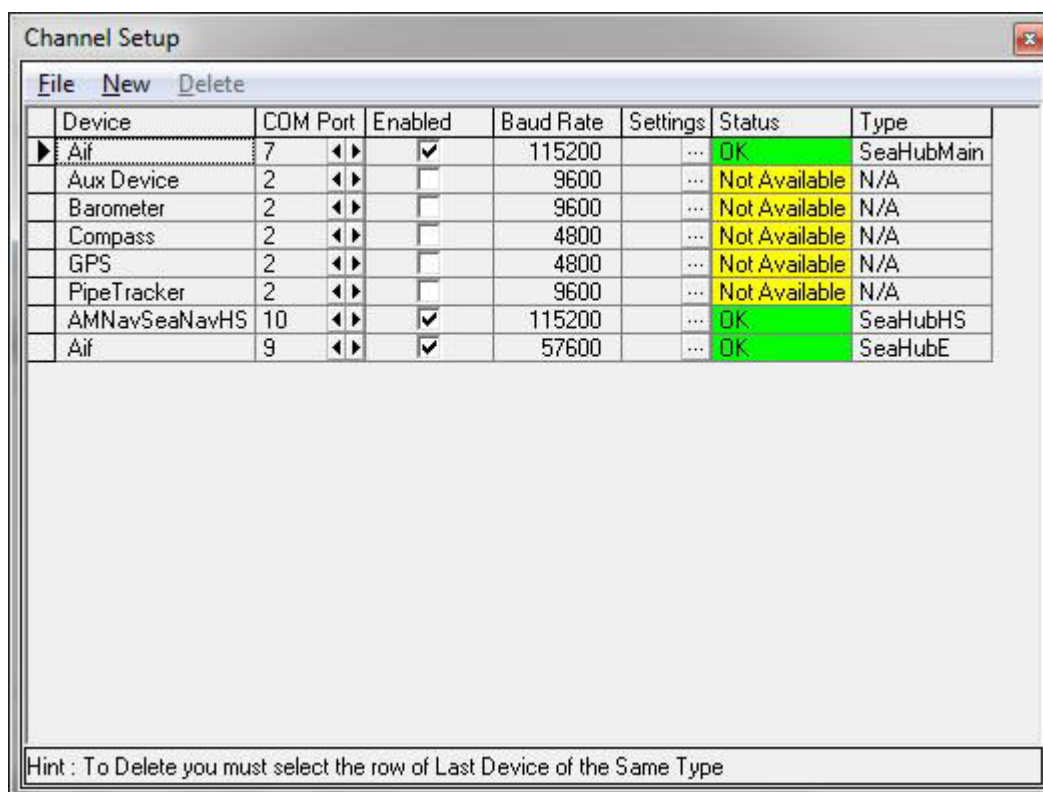

Now add a port for the Micron or SeaSprite Sonar connection for use when Responder mode operation is required. This is done by selecting New from the menu bar followed by Aif from the sub-menu. The new Aif device must now be configured to Port B by adjusting the COM Port number with the spin edit button until the Type="SeaHubB" as shown below, click the check box to enable and close the 'Channel Setup' page by clicking the 'X' at the top right of the window.

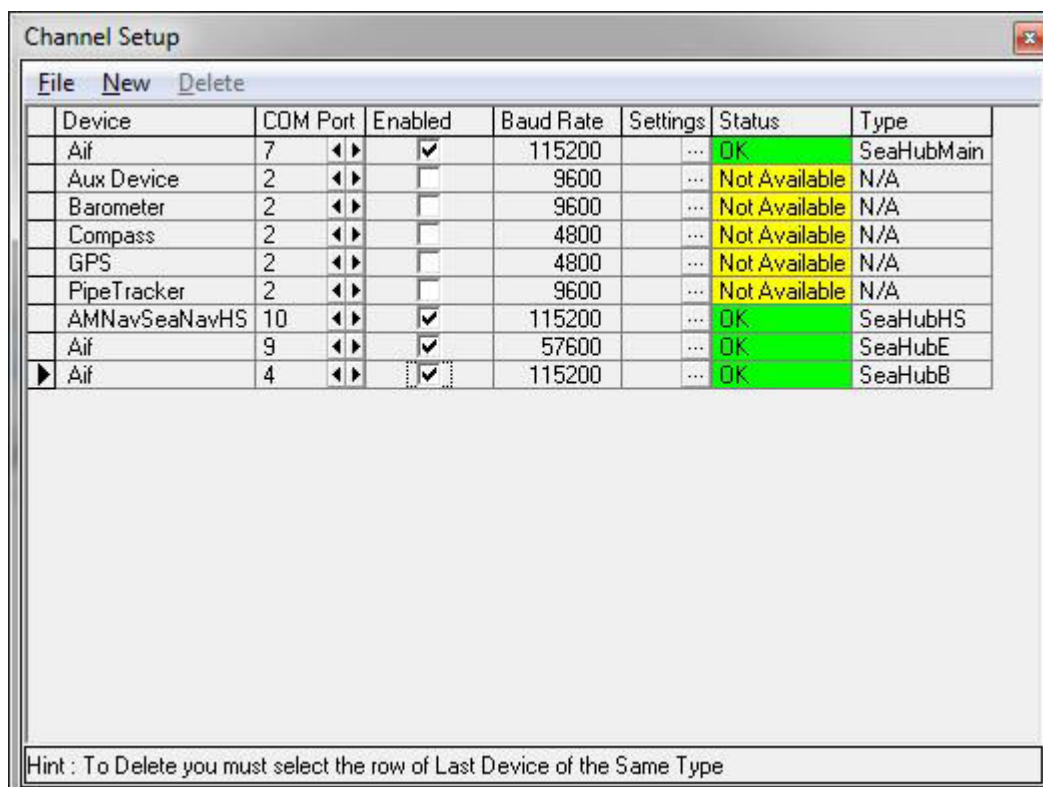

The main setup page should now list two Node numbers in the table; these are the nodes for the MicronNav100 (SEAHUBNAV100) and the attitude sensor (MINIATTSEN) inside the USBL Dunking Transducer head.

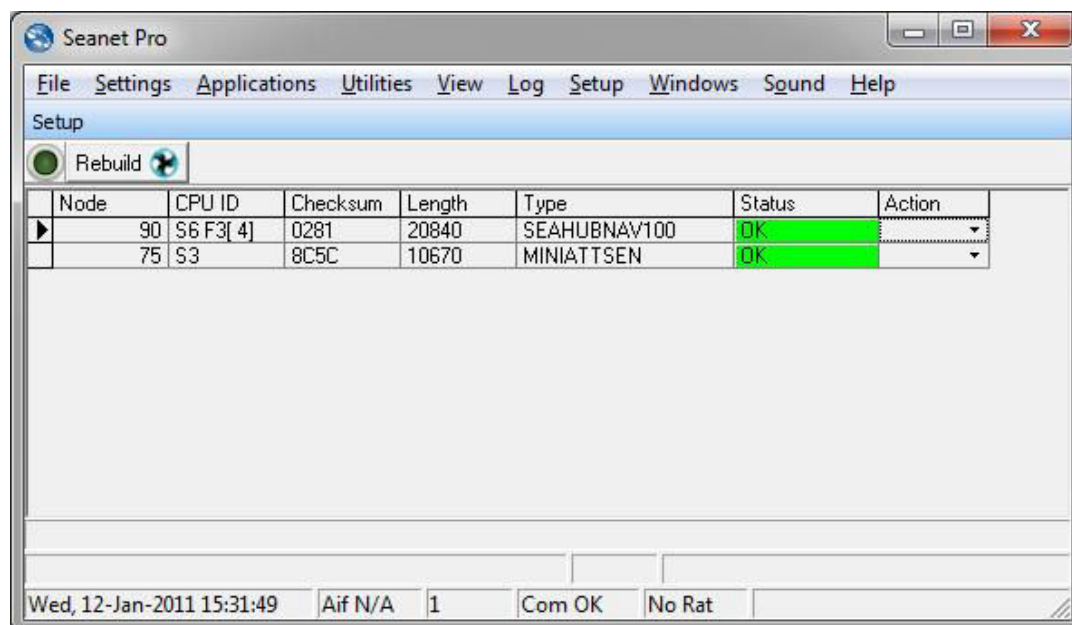

Node 90 Surface MicronNav100 Interface Hub.

Node 75 Attitude Sensor built into the USBL Dunking Transducer.



Note

The USBL Dunking Transducer itself does not appear as a node number.

Finally switch off the power supply to the MicronNav100 Hub.

3.2.4. Subsea Hardware Responder Configuration

Installation

As of **Seanet Pro V2.23 Build 539** the MicronNav Responder unit can be connected in a variety of different ways:

- Through the **AUX Port** of a Sonar connected on **Port B** of the MicronNav Hub - *this is the factory default option*
- Through the **AUX Port** of a Sonar connected on **Port D** of the MicronNav Hub
- Directly connected to **Port B** of the MicronNav Hub
- Directly connected to **Port D** of the MicronNav Hub
- Through the **AUX Port** of a Gemini Sonar



Note

In all cases, the communications setup for a Micron Responder are: **RS232, 9600 Baud, 8 Data bits, 1 Stop Bit, No Parity**. It is not advisable to attempt to

change these default settings of a Micron Responder without first seeking help and advice from *Tritech International Ltd*.

Ensure the *Tritech International Ltd* Sonar has been installed on the ROV as detailed in the appropriate product manual. Install the MicronNav sub-sea Modem Head on the ROV as detailed in Section 3.1.2, "Mounting the Subsea Modem Head" and checking the connector threads are clean and contacts dry carefully connect the main connector port of the modem head to the auxiliary connector port of the sonar head using the double ended interconnect lead.

Ensure the blanking cap on the auxiliary port of the modem head is fitted.

Connect the top side communications to the appropriate port on the rear of the MicronNav100 Interface Hub using the previously wired cable as detailed in Section 3.1.6, "Electrical Connection to the Surface MicronNav100 Interface Hub".

Switch on the power supply to the MicronNav100 Interface Hub and click the *Seanet Setup* icon on the desktop, if the Surface Hardware installation and configuration has been carried out correctly the *SEAHUBNAV100* (Node 90) and *MINIATTSEN* (Node 75) should appear in the device list.

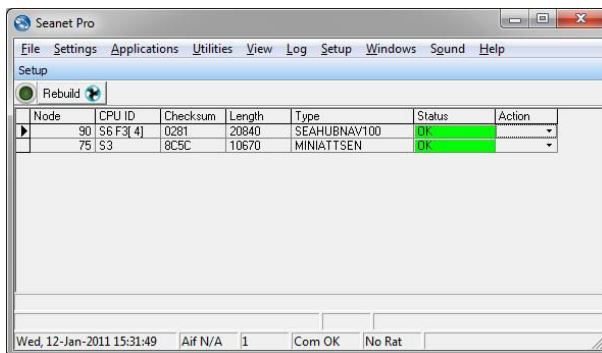

The system now needs to be configured in order for it to correctly operate the Micron Responder. The exact method will depend on how the Micron Responder has been connected. Open the *Setup* page of Node 90, click on the *SeaNav100* tab and then select the method being used to connect the MicronNav Responder.

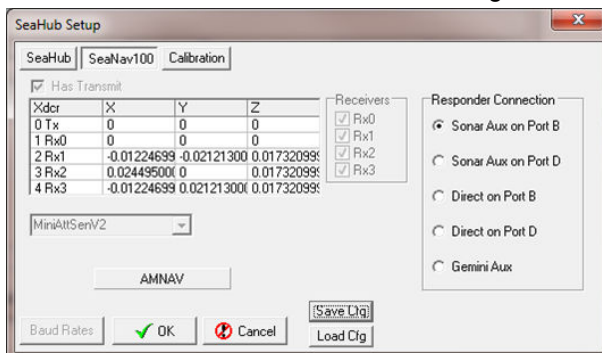

Connecting the Micron Responder via a Sonar AUX port

Surface to Sonar Communication Configuration

An example of a Micron Responder being used with a Sonar is:

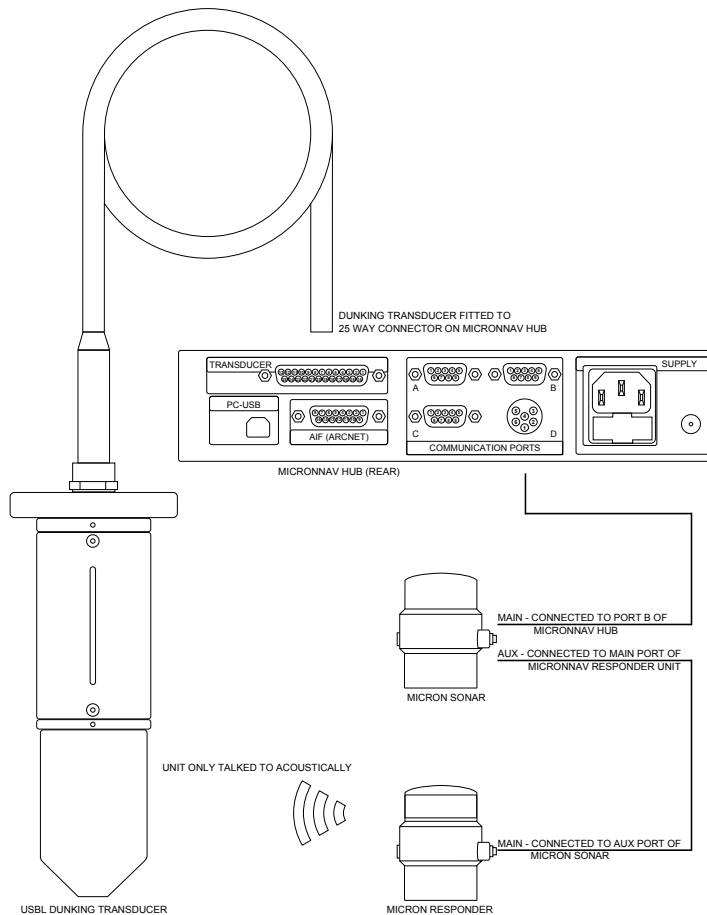

For systems where the MicronNav Reponser has been connected to the AUX Port of a *Tritech International Ltd* Sonar, Seaset Pro will need to be setup to work with the ROV communications link. For the appropriate Port on the MicronNav Hub (Port B or Port D) - select Utilities from the top menu bar followed by Com Setup to open the Channel Setup page and check the baud rate of the port matches that of the Sonar Main port (default 115200) and ROV communications link, if it requires changing click the settings button on the row to open the AifSetupForm and adjust the baud rate accordingly, click Ok to confirm the setting and close the form and then close the Channel Setup form.

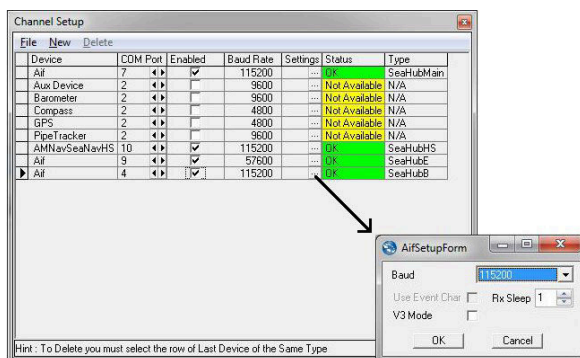

Now check the communications protocol type of port B matches that of the Sonar Main port and ROV communications link, click the action arrow in the SEAHUBNAV100 row followed by

Setup from the sub-menu, you will be warned that this may change the behaviour of the Node, select OK to continue and the SeaHub Setup page will be displayed, set up Port B Mode for RS232 or RS485 accordingly.

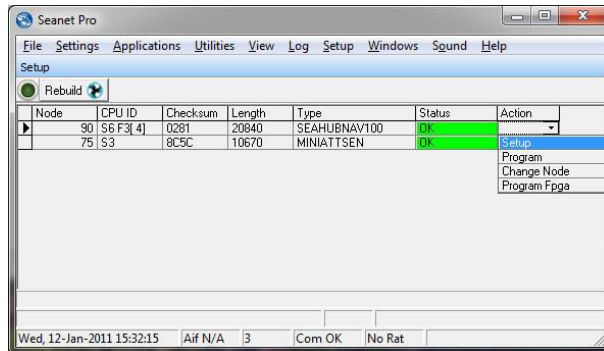

Confirm the settings and close the SeaHub Setup page by clicking the Ok button.

Apply power to the Sonar/ROV and if the Subsea Hardware installation and configuration has been carried out correctly, once the sonar has initialised MICRON (Node 2) should be added to the device list as shown below.

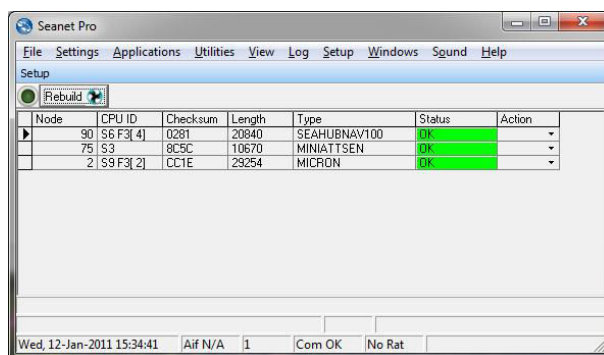

Sonar to Sub-sea Modem Communication Configuration

The Sonar Aux port now need to be configured for the MicronNav sub-sea Modem Head - click the action arrow in the MICRON row followed by Setup from the sub-menu, you will be warned that this may change the behaviour of the Node, select OK to continue and the Digital Sonar Setup page will be displayed, ensure Comms Mode Aux is set to RS232 and then click the Baud Rates button at the bottom left of the page to open the Comms Setup window and ensure the Async 1 [Head Aux/Aif Rat] Baud Lo Speed and Hi Speed are set to 9600.

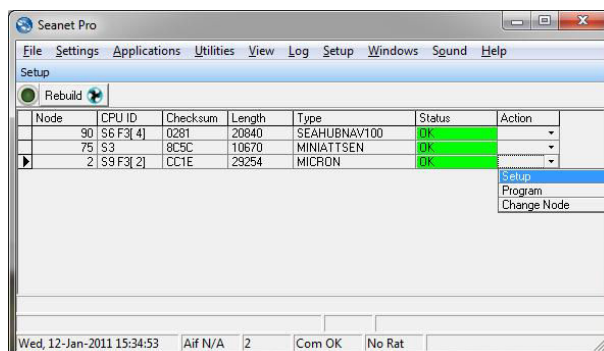

Digital Sonar Setup

Chan 1 | Calibration

Transmitter DDS

Start Frequency: 650000
End Frequency: 750000
Pulse Length: 300

Receiver Filter

Start Frequency: 650000
End Frequency: 750000
Filter Length: 300
Alpha Shading: 0.540

Receiver

Threshold: 50
Rx Det Width: 100
Rx Det Offset: 0
RSSI Offset: 115
TVG Slope: 100

Transmitter

Duty Cycle: 9

Sample Rate: 1803571 Hz
MAC Taps: 540
MAC Time: 299.41 us
MAC Blocks: 10

Controls

HasMotor
 Half Duplex
 Dual Filter
 Has Attitude
 Disable AutoComms

Tx Drive: Normal
 Both
 PSBP

Board Rev: MICRON
Aux Rate: 1000

Comms Mode

Main: RS232
Aux: RS232

Comms Board Version
 Has COMV6

FPGA
Fpga OK, UC=15052008 ID={ 2 }

Option	SpR	Spd	LL	RL	Gain
Pan	200	800	0	0	200
Tilt	0	0	0	0	0

Baud Rates OK Cancel Load Cfg Save Cfg

Comms Setup

Lo Speed Hi Speed

ARCNET

Baud: 78 156
Sens: Neutral Neutral
11 (Normal)

Lo Speed Hi Speed

Async 0 (Serial LAN AUX 1)

Baud: 9600 115200
Parity: None None
Data: 8 Bits 8 Bits

Lo Speed Hi Speed

Async 1 (Head Aux/ Aif Rat)

Baud: 9600 9600
Parity: None None
Data: 8 Bits 8 Bits

OK Cancel

Confirm the settings and close the **Comms Setup** page by clicking the **Ok** button and then confirm the **Sonar Setup** and return to the **Seanet Setup** page by clicking the **Ok** button on the **Digital Sonar Setup** page.

Connecting to a MicronNav Responder directly from a MicronNav Port

An example of a Micron Responder being used directly from the MicronNav is:

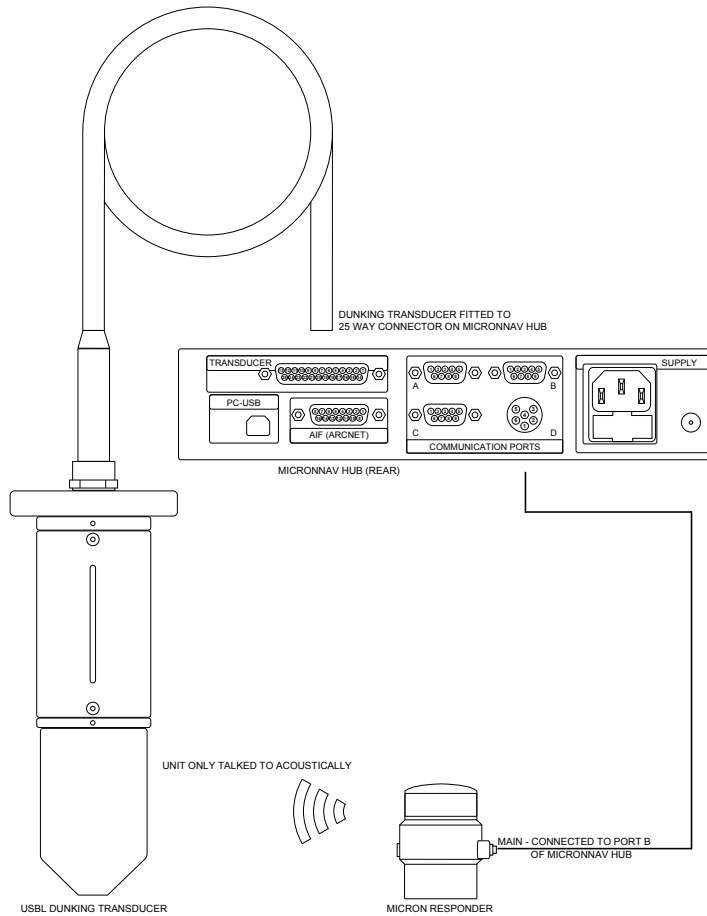

The MicronNav Responder can be directly connected to either Port B or Port D of the MicronNav Hub and provide direct communications to it.

Select Utilities from the top menu bar followed by Com Setup to open the Channel Setup page. Select the Direct Responder option from the New drop down menu.

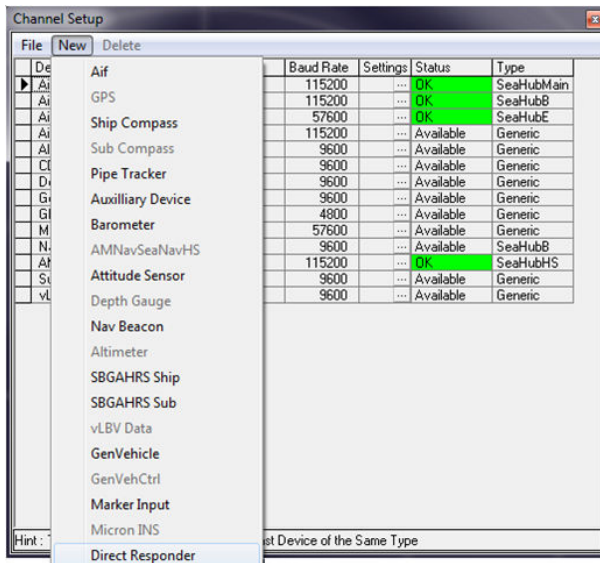

Configure the Direct Responder device to point to either the SeaHubB or SeaHubD port and ensure that the port settings are correct for establishing direct communication with the MicronNav Responder itself.

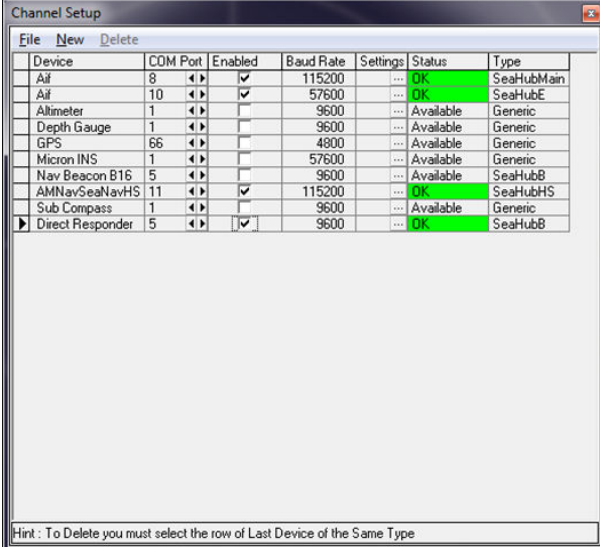

The screenshot shows a 'Channel Setup' dialog box with a table of device configurations. The table has columns for Device, COM Port, Enabled, Baud Rate, Settings, Status, and Type. The 'Status' column contains green cells with 'OK' or 'Available' text. The 'Direct Responder' row is highlighted with a mouse cursor.

Device	COM Port	Enabled	Baud Rate	Settings	Status	Type
Aif	8	<input checked="" type="checkbox"/>	115200	...	OK	SeaHubMain
Aif	10	<input checked="" type="checkbox"/>	57600	...	OK	SeaHubE
Altimeter	1	<input type="checkbox"/>	9600	...	Available	Generic
Depth Gauge	1	<input type="checkbox"/>	9600	...	Available	Generic
GPS	66	<input type="checkbox"/>	4800	...	Available	Generic
Micron INS	1	<input type="checkbox"/>	57600	...	Available	Generic
Nav Beacon B16	5	<input type="checkbox"/>	9600	...	Available	SeaHubB
AMNavSeaNavHS	11	<input checked="" type="checkbox"/>	115200	...	OK	SeaHubHS
Sub Compass	1	<input type="checkbox"/>	9600	...	Available	Generic
Direct Responder	5	<input checked="" type="checkbox"/>	9600	...	OK	SeaHubB

Hint : To Delete you must select the row of Last Device of the Same Type



Note

Seanet Pro will **not** show a Node number for any connected MicronNav Responder.

Connecting to a MicronNav Responder from a Gemini AUX Port

An example of a Micron Responder being used on the AUX Port of a Gemini is:

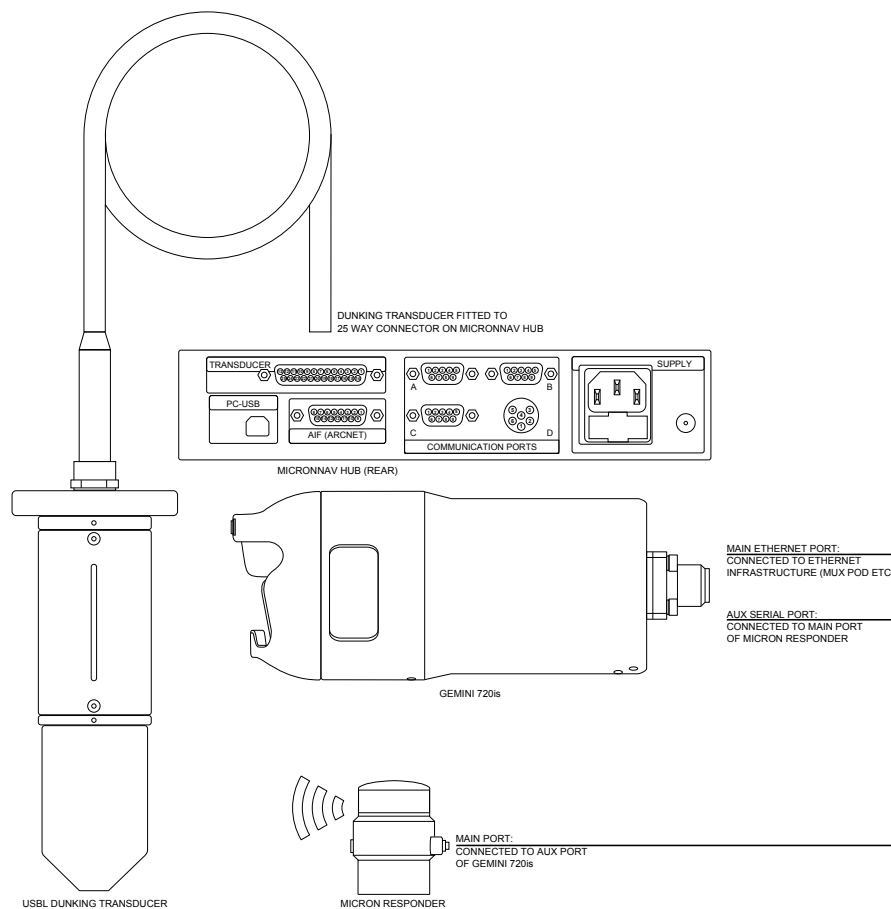

The MicronNav Responder can be connected to the `AUX Port` of a Gemini unit (720i, 720id or 720is) so long as the Gemini unit is identified as being Node 100.



Caution

When utilising the `AUX Port` of a Gemini Sonar, care should be taken to ensure that the power supplied to the unit does not exceed the rating of the Responder unit. Gemini 720i / 720id units do not regulate the `AUX Port` voltage so the Sonar itself should never be supplied with more than 48V. The Gemini 720is *does* regulate its `AUX Port` voltage to 24V.

The `AUX Port` of the Gemini should be setup to match the MicronNav Responder communications (*RS232, 9600 Baud, 8 Data bits, 1 Stop Bit, No Parity*). Please refer to the relevant Gemini Product Manual for detailed instructions on this process.

3.2.5. Subsea Hardware Transponder Configuration

Install the MicronNav sub-sea Modem Head as detailed in Section 3.1.2, “Mounting the Subsea Modem Head” and, checking the connector threads are clean and contacts dry, carefully connect the previously wired 6-pin Micron Connector Pigtail lead to the “Main” connector port of the Modem Head.

Ensure the blanking cap on the “Aux” port of the Modem Head is fitted.



Note

In transponder mode a wired communications connection is not required.

If it is required to operate in Transponder mode and power the Modem from a Micron Sonar *Aux* port using the standard Micron cable the communications type of the Sonar *Aux* port should be set to match the communications type of the Modem head.

3.2.6. Connecting optional third party GPS Receiver

The MicronNav system can be configured to accept a NMEA GPS input string from an external third party GPS receiver enabling synchronisation of the Seanet display and ROV tracked position to true world position.



Note

If a GPS Receiver is to be used it is important to be aware that a low cost and low accuracy GPS device will limit the accuracy of the MicronNav system - the MicronNav tracked position will only be as good as the reference GPS signal it is using.

The GPS receiver can be connected to any of the free USB or Serial interface connectors available on the MicronNav100 Interface Hub (see Section 3.1.6, “Electrical Connection to the Surface MicronNav100 Interface Hub” for serial port pin out details), or any available serial ports on the computer.

To configure the system to accept the GPS receiver switch on the power supply to the MicronNav100 Interface Hub and click the *Seanet Setup* icon on the desktop to display the device list, select *Utilities* from the top menu bar followed by *Com setup* from the sub-menu to open the *Channel Setup* page and configure the GPS entry for the correct COM port used for the GPS input and click the check box to enable. Check the baud rate matches that of the GPS receiver (normally 4800 baud) and if it requires changing click the settings button in the GPS row to open the *Comms Settings* panel and adjust the baud rate accordingly, click *Ok* to confirm the setting and close the form and then close the *Channel Setup* form.

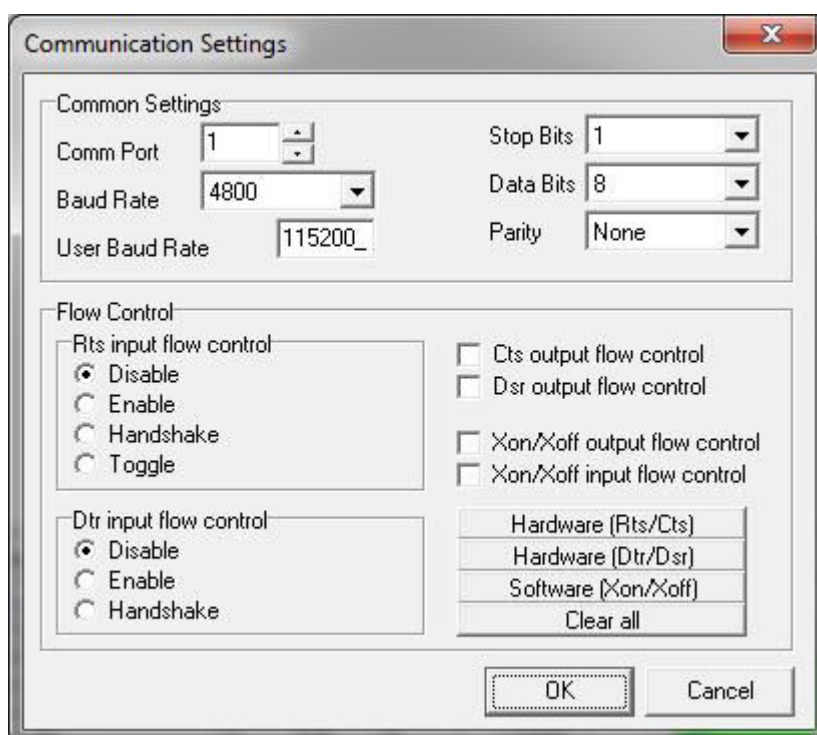
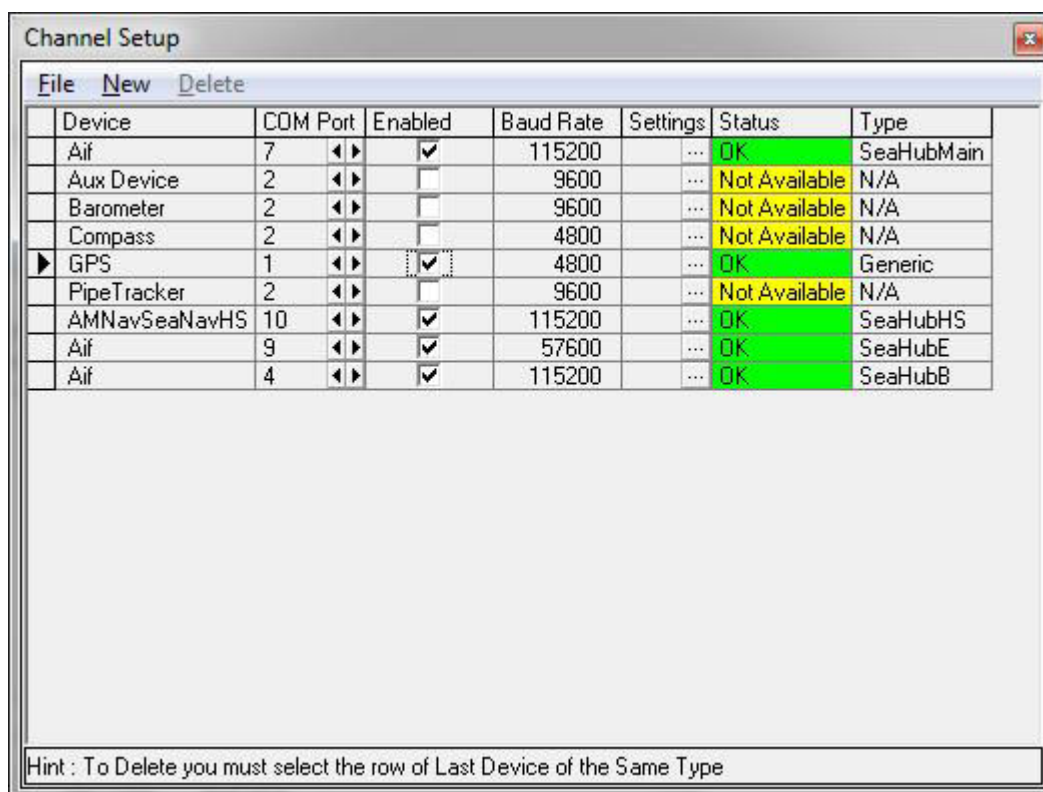

The above example shows the GPS receiver on COM 1 which in this case is a Generic COM Port device (e.g. DE-9 port) which creates its own virtual COM port.



Note

Virtual COM ports can be identified using Device Manager from the Windows Control Panel.

Check for correct configuration of the GPS interface by selecting Utilities from the top menu bar followed by GPS Diagnostic from the sub-menu to open the GPS Diagnostic window, if the GPS installation has been successful the GPS data will be visible in the window. If no data is displayed re-check the Com Port baud rate settings and confirm the GPS receiver is switched on.

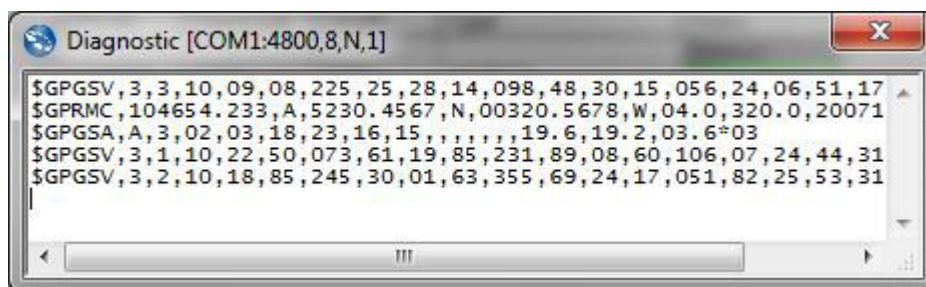

3.2.7. Connecting optional third party High Accuracy Heading/Pitch/Roll MRU Sensors

The USBL Dunking Transducer integral Magnetic Heading and Pitch/Roll sensor that enables the MicronNav application to make corrections to world axis is particularly effective when operating from a non-magnetic mobile platform/vessel or fixed dockside, however when operating from a steel hull vessel the integral sensor will be affected by magnetic interference from the vessel and it is recommended in this type of installation that an external ships Compass & Motion Reference Unit (MRU) is used to provide the Heading and Pitch/Roll information.

The other occasion when an external Compass & MRU might be considered is if a greater degree of bearing accuracy is required from the system.

The external Compass & MRU can be connected to any of the free Serial interface connectors available on the MicronNav100 Interface Hub (see Section 3.1.6, "Electrical Connection to the Surface MicronNav100 Interface Hub" for serial port pin out details).

The Compass and Attitude data will sometimes be supplied from separate devices in which case it will be necessary to use two serial ports.



Note

It is possible to use an External (Ship) Heading with the USBL Dunking Transducer Pitch/Roll. Or, External (Ship) Heading/Pitch/Roll can be used instead of USBL Heading/Pitch/Roll.

Seanet Pro will `auto detect` the incoming data string from the external device, no data string setup is required (although the COM port will require to be configured to accept the data connection as detailed below).

Heading/Pitch/Roll from a single external device

To configure the system to accept the heading & pitch/roll data from a single external device switch on the power supply to the MicronNav100 Interface Hub and click the `Seanet Setup` icon on the desktop to display the device list, select Utilities from the top menu bar followed by Com Setup from the sub-menu to open the `Channel Setup` page and disable the integral sensor by un-checking Enabled check box for SeaHubE.

Configure the Compass entry for the correct COM port used for the external device input and click the check box to enable, check the baud rate matches that of the external device

and if it requires changing click the settings button in the **Compass** row to open the **Comms Settings** panel and adjust the baud rate accordingly, click **Ok** to confirm the setting and close the form and then close the **Channel Setup** form.

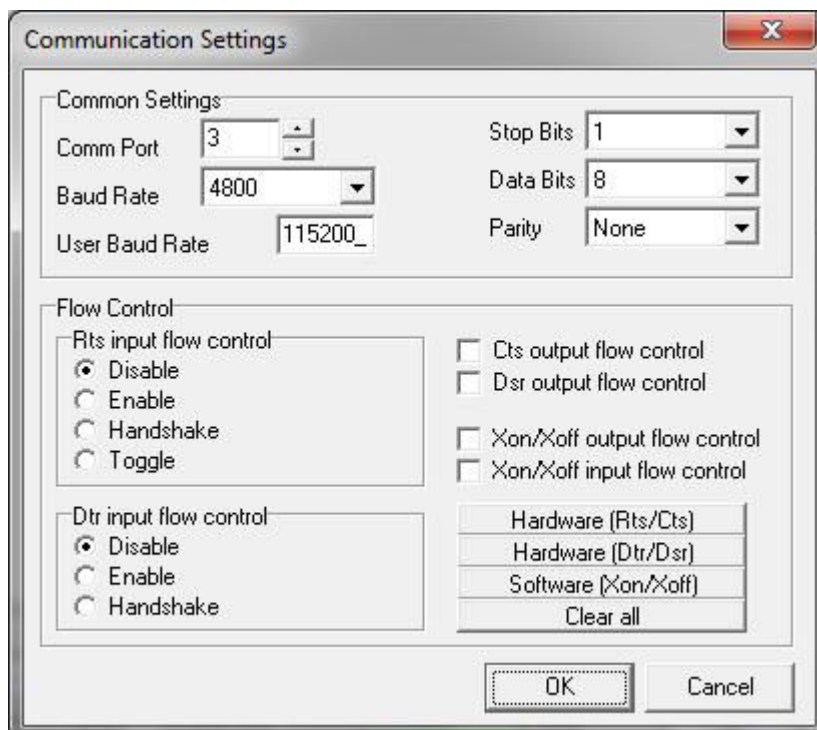
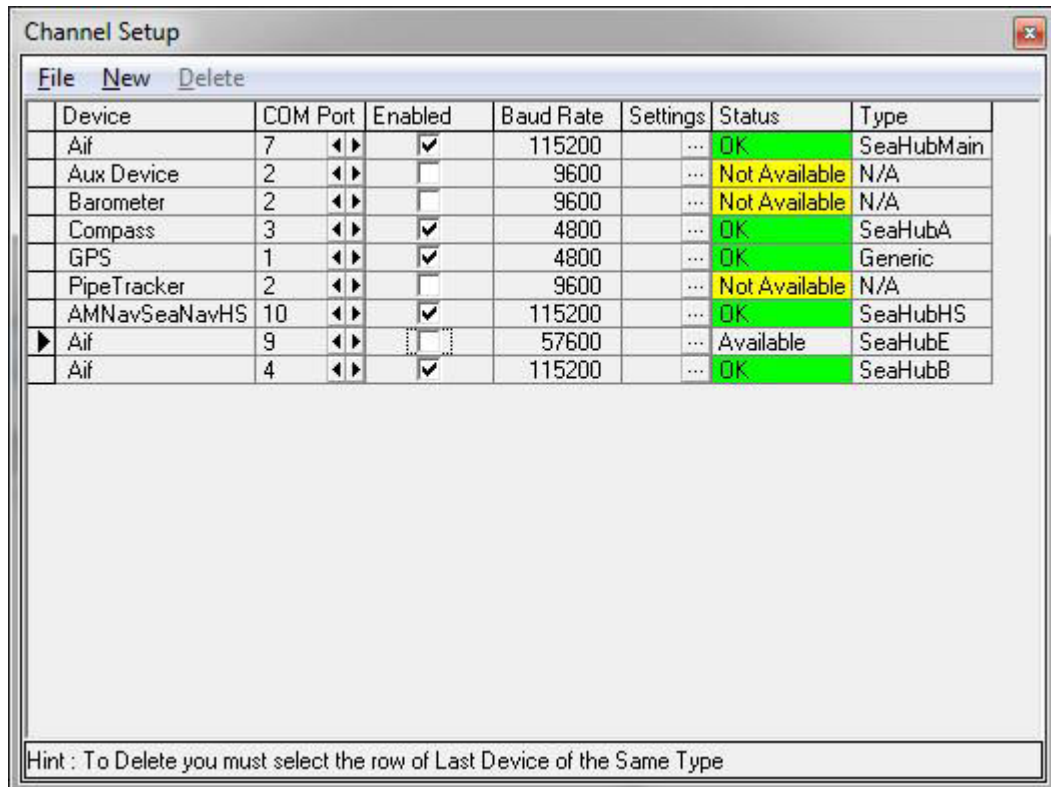

The above example shows the external Heading & Pitch/Roll sensor on COM 3 which in this case is Port A on the MicronNav100 Hub.

Check the integral sensor is switched off in **Seanet Setup - Node 75 (MINIATTSEN)** should no longer appear in the device list.

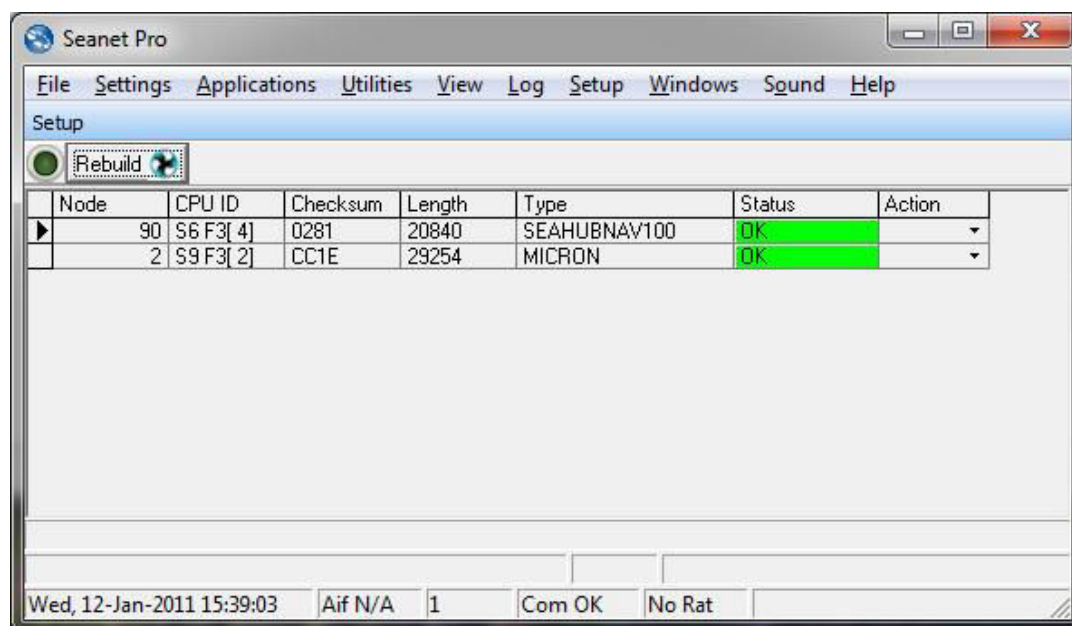

Note

It is not necessary to disable the Integral Sensor in the Channel Setup but is good practice to do so if External Heading, Pitch and Roll data is to be applied. In the Job Setup (i.e. Create New Job or Edit Job), ensure to select Use Ship Compass for the Heading and also select No Attitude Sensor, Use Platform for the Attitude Sensor setting.

Heading/Pitch/Roll from separate external devices

To configure the system to accept the heading & pitch/roll data from two separate external devices switch on the power supply to the MicronNav100 Interface Hub and click the Seagnet Setup icon on the desktop to display the device list, select Utilities from the top menu bar followed by Com Setup from the sub-menu to open the Channel Setup page and disable the integral sensor by un-checking Enabled check box for SeaHubE. Configure the Compass entry for the correct COM port used for the external Compass input and click the check box to enable, check the baud rate matches that of the external Compass and if it requires changing click the settings button in the Compass row to open the Comms Settings panel and adjust the baud rate accordingly, click Ok to confirm the setting and close the form.

Now configure the Attitude Sensor entry for the correct COM port used for the external MRU (pitch/roll) input and click the check box to enable (Note: if there is no Attitude Sensor listed select New from the menu bar followed by Attitude Sensor from the sub-menu to add to the list), check the baud rate matches that of the external MRU and if it requires changing click the settings button in the Attitude Sensor row to open the Comms Settings panel and adjust the baud rate accordingly, click Ok to confirm the setting and close the form and then close the Channel Setup form.

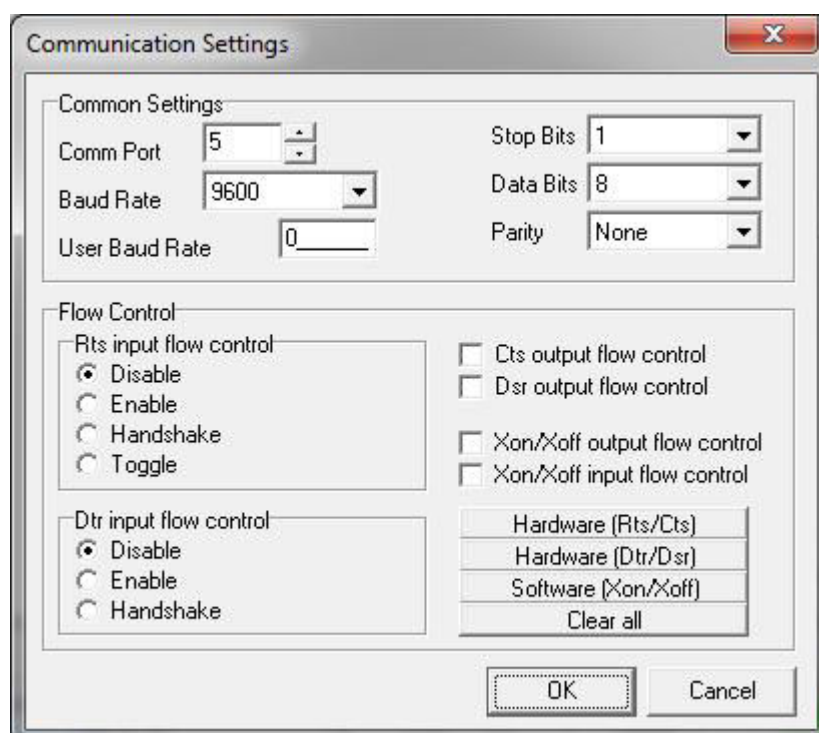
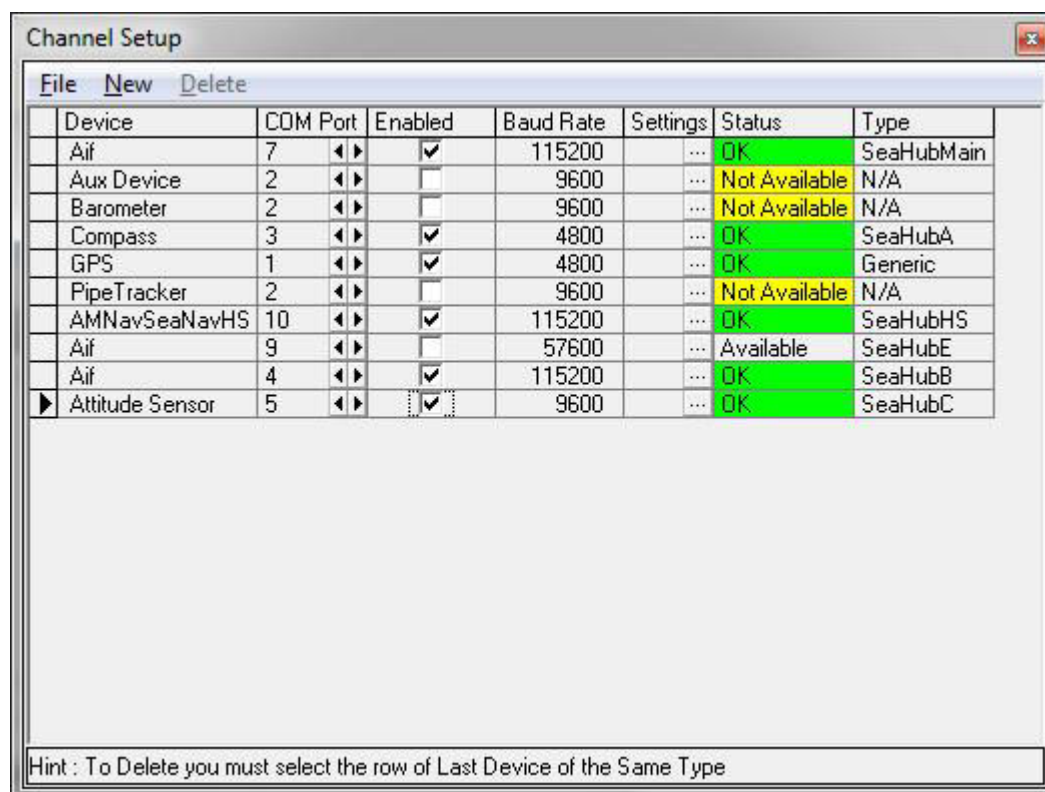

The above example shows the external Compass sensor on COM 3 which in this case is Port A on the MicronNav100 Hub and the external MRU (pitch/roll) on COM 5 which in this case is Port C on the MicronNav100 Hub. Check the integral sensor is switched off in Seanet Setup - Node 75 (MINIATTSEN) should no longer appear in the device list.

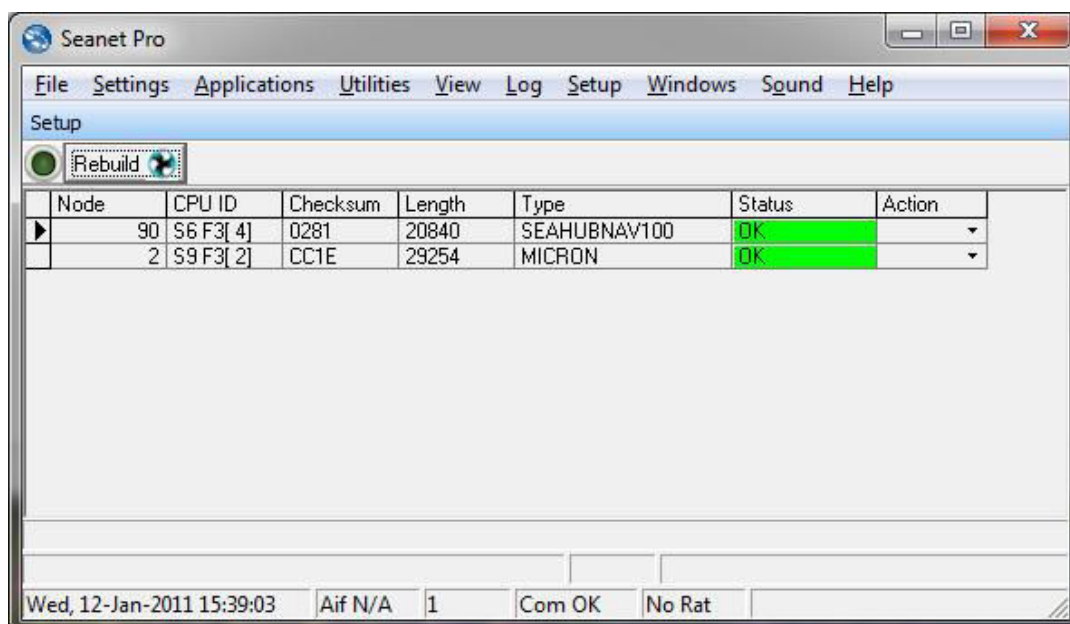

Selecting External Heading/Pitch/Roll data in Job

After configuring a COM Port for the External data input (Section 3.2.7, “Connecting optional third party High Accuracy Heading/Pitch/Roll MRU Sensors”), to then apply External Heading/Pitch/Roll data, i.e. from a Ship Compass or MRU, it must be selected in the Job.

A Job should first be created to create the operational environment for the Navigation system to work in (Section 4.1.4, “Creating a New Job (Using Wizard)”). If a Job is currently created and loaded then it is also possible to edit this Job to make and save necessary changes (Section 4.1.5, “Editing an Existing Job”). The example below will show the configuration that needs to be done during an Edit Job (N.B. The same selection controls will be found when Creating a new Job).

To apply External Heading/Pitch/Roll data, select MicronNav from the top menu bar and select Job – Edit Job to open the Edit Job panel (as shown below - if this menu option is not displayed click inside the Navigation window first). Then follow a couple of Steps to make the necessary configurations.

Step 1: In the Job Setup tab-page, set the Heading drop-down selection to Use Ship Compass

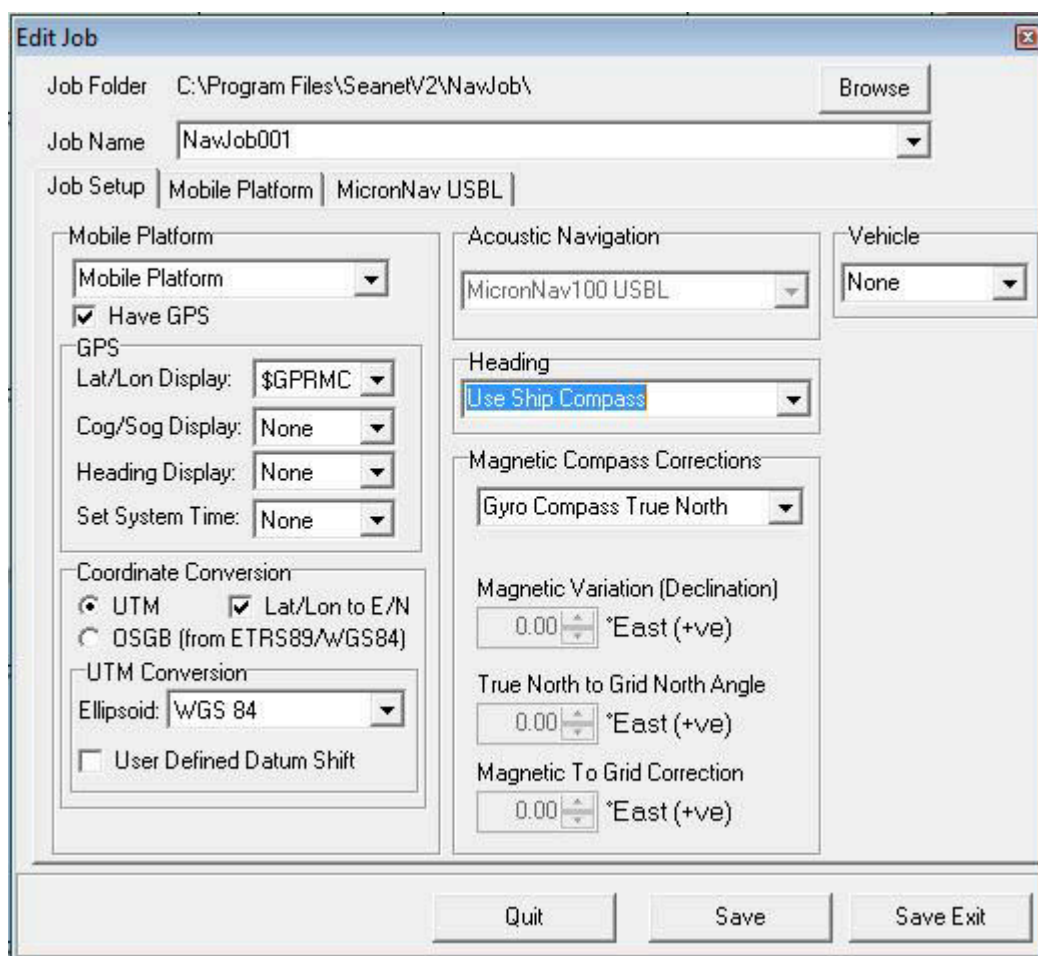

Step 2: Next, in the `MicronNav USBL` tab-page, set the Attitude Sensor drop-down to `No Attitude Sensor, Use Platform`

Edit Job

Job Folder: C:\Program Files\SeanetV2\NavJob\ Browse

Job Name: NavJob001

Job Setup | Mobile Platform | MicronNav USBL

USBL Transducer Installed Offsets From Datum

AM100 SBL	X Coord	Y Coord	Z Coord
Transducer	0.00	0.00	0.00

AM100 SBL	Roll °	Pitch °	Yaw °
OffSets	0.00	0.00	0.00

Attitude Sensor

No Attitude Sensor, Use Platform

Quit Save Save Exit

Step 3: Click on **Save Exit** to immediately update the Job and apply changes. The Integral Attitude Sensor Heading/Pitch/Roll will no longer be applied and External MRU data input(s) will now be applied instead.

External Heading with Integral Sensor Pitch/Roll

The information given in Section 3.2.7, “Connecting optional third party High Accuracy Heading/Pitch/Roll MRU Sensors” describes the configuration of an External Heading/Pitch/Roll input to be applied in place of the Integral Attitude Sensor Heading/Pitch/Roll data (e.g. Node 75 MINIATTSEN).

It is also possible to re-enable the Integral Sensor (Node 75 MINIATTSEN) and apply only its Pitch/Roll data to calculations, whilst using only Heading data from an External (Ship) Compass input. This effectively replaces the Heading from the Integral Sensor with External Ship Compass data.

To configure the system to accept Heading from an External Compass device, switch on the power supply to the MicronNav100 Interface Hub and click the *Seanet Setup* icon on the desktop to display the device list, select *Utilities* from the top menu bar followed by *Com Setup* from the sub-menu to open the *Channel Setup* page and leave the Integral sensor Enabled (i.e. the check box for *SeaHubE* should be ticked). The Integral sensor needs to remain enabled for application of its Pitch/Roll data.

Configure the *Compass* entry for the correct COM port used for the external device input and click the check box to enable, check the baud rate matches that of the external device and if it requires changing click the settings button in the *Compass* row to open the *Comms Settings* panel and adjust the baud rate accordingly, click *Ok* to confirm the setting and close the form and then close the *Channel Setup* form.

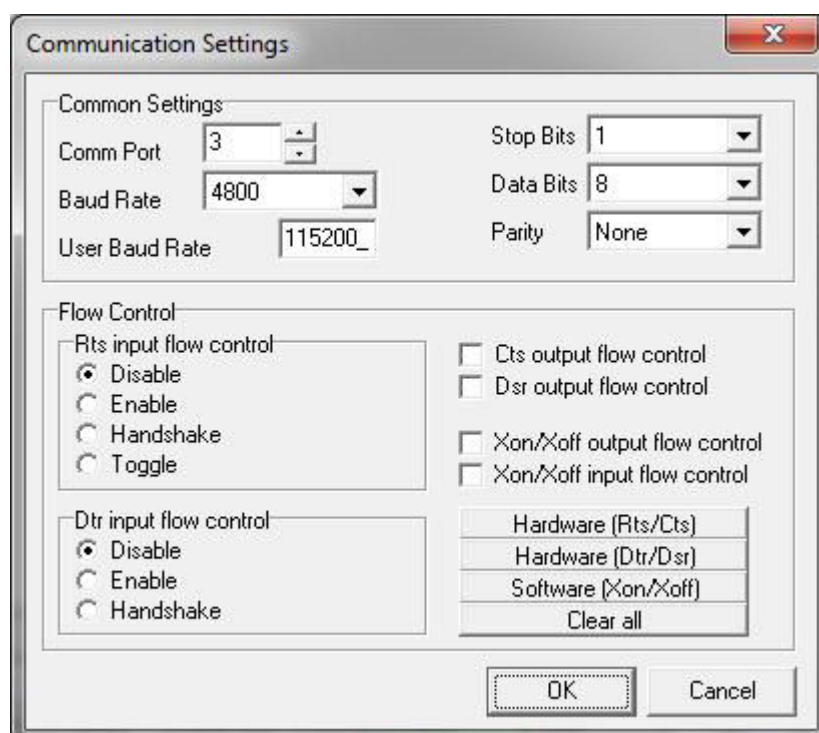
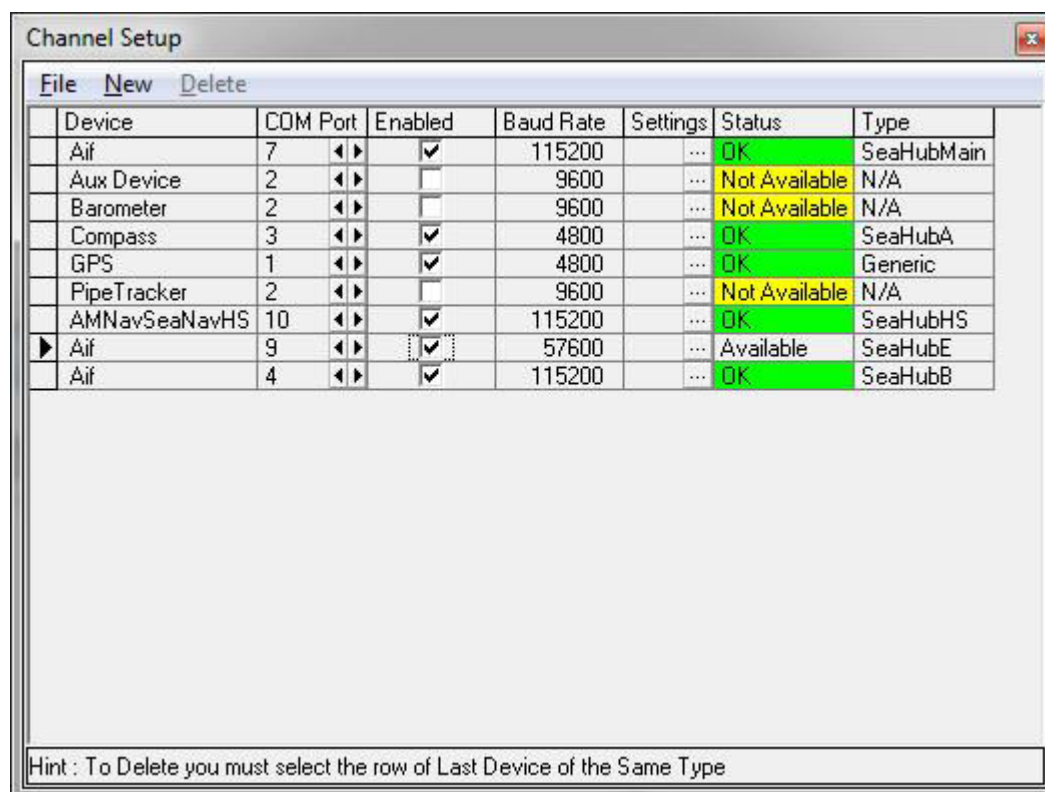

The above example shows the external Heading sensor on COM 3 which in this case is Port A on the MicronNav100 Hub.

Selecting External Heading data in Job

After configuring a COM Port for the External Compass data input, to then apply External Heading, i.e. from a Ship Compass, it must be selected in the Job.



Note

This option only applies External Compass data whilst maintaining use of Pitch/Roll data from the Integral Attitude Sensor.

A Job should first be created to create the operational environment for the Navigation system to work in (Section 4.1.4, "Creating a New Job (Using Wizard)"). If a Job is currently created and loaded then it is also possible to edit this Job to make and save necessary changes (Section 4.1.5, "Editing an Existing Job").

The example below will show the configuration that needs to be done during an Edit Job. The same selection controls will be found when Creating a new Job)

To apply only External Heading data, whilst using Pitch/Roll from the Integral Sensor, select MicronNav from the top menu bar and select Job – Edit Job to open the `Edit Job` panel (as shown below - if this menu option is not displayed click inside the Navigation window first). Then follow a couple of Steps to make the necessary configuration,

Step 1: In the `Job Setup` tab-page, set the Heading drop-down selection to `Use Ship Compass`



Note

If there is a heading string as part of the GPS input, i.e. such as from a GPS Compass device, then this can be applied as the Heading input instead by selecting `Use GPS Setting`.

The screenshot shows the 'Edit Job' dialog box with the following configuration:

- Job Folder:** C:\Program Files\Seane\V2\NavJob\
- Job Name:** NawJob001
- Job Setup:** Mobile Platform | MicronNav USBL
- Mobile Platform:** Mobile Platform (dropdown)
- Have GPS**
- GPS:**
 - Lat/Lon Display: \$GPRMC (dropdown)
 - Cog/Sog Display: None (dropdown)
 - Heading Display: None (dropdown)
 - Set System Time: None (dropdown)
- Coordinate Conversion:**
 - UTM Lat/Lon to E/N
 - OSGB (from ETRS89/WGS84)
 - UTM Conversion:** Ellipsoid: WGS 84 (dropdown)
 - User Defined Datum Shift
- Acoustic Navigation:** MicronNav100 USBL (dropdown)
- Vehicle:** None (dropdown)
- Heading:** Use Ship Compass (dropdown)
- Magnetic Compass Corrections:** Gyro Compass True North (dropdown)
- Magnetic Variation (Declination):** 0.00 °East (+ve)
- True North to Grid North Angle:** 0.00 °East (+ve)
- Magnetic To Grid Correction:** 0.00 °East (+ve)

Buttons at the bottom: Quit, Save, Save Exit

Step 2: Next, in the MicronNav USBL tab-page, ensure the Attitude Sensor drop-down is set to MicronNav100 Attitude Sensor.

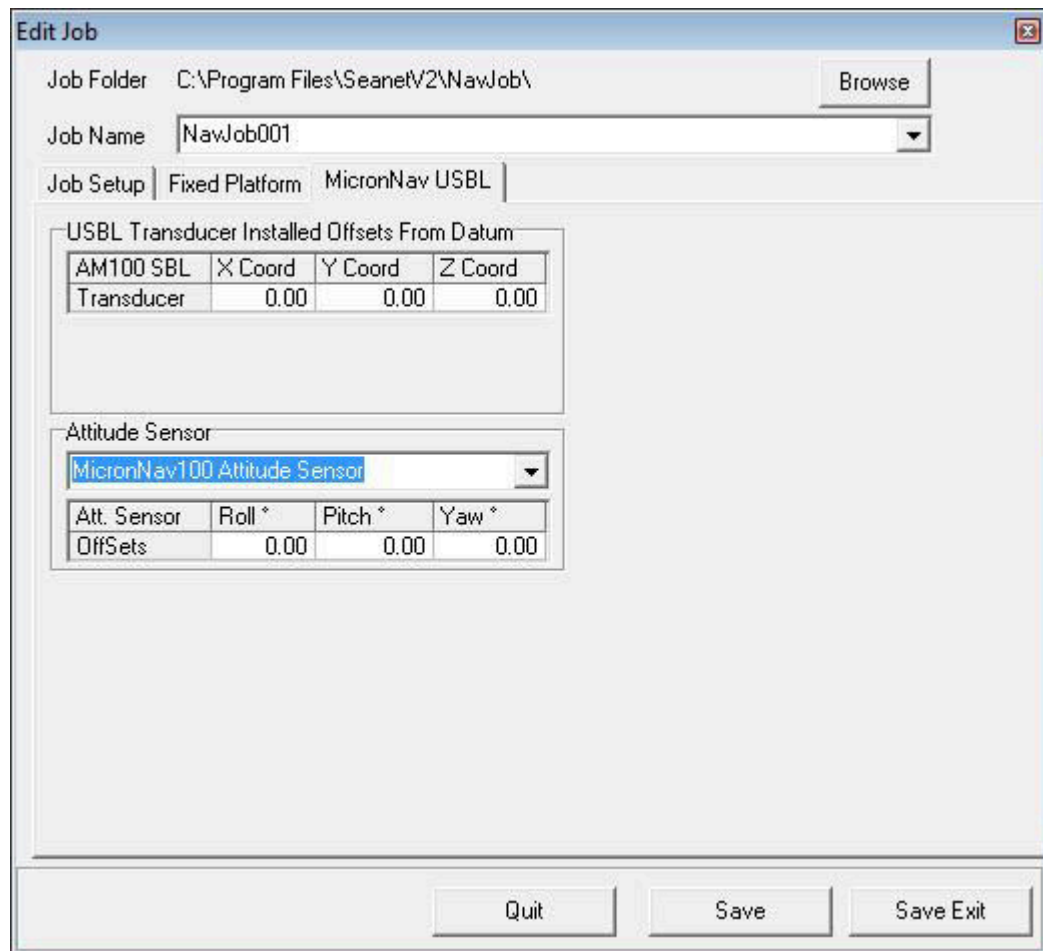

Step 3: Click on **Save Exit** to immediately update the Job and apply changes. The Integral Attitude Sensor Pitch/Roll will still be applied and the External Compass data input(s) will now be used in place of Integral Sensor Compass data.

Heading/Pitch/Roll string compatibility

The following strings are detected and interpreted by Seanet Pro as standard

Compatible Strings with Attitude:

TCM2	\$C123.4P12.3R12.3T12.3X123.4Y123.4Z123.4E000*FF<CR><LF>
NMEA `TRO`	\$--TRO,x.xx,a,y.yy,b*kk<CR><LF>
NMEA `TRH`	\$--TRH,x.xx,a,y.yy,b,z.zz,c*kk<CR><LF>
CDL1	H123.4P+123.45R+123.45T00.0D00000.0B00.0FR<CR><LF>
MDL	H0750P-0019R-0022<CR><LF>
Digilog/OceanTools	H0750P-0019R-0022E<CR><LF>
CDL MicroTilt	P+12.34R+12.34<CR><LF>
TSS1	:XXAAAASMHQHQRMMMMPPPP<CR><LF>
SMC `SMCS`	\$PSMCS,±yy.yyy,±xx.xxx,±hh.hh<CR><LF>
SMC `SMCD`	\$PSMCD,±yy.yy,±xx.xx,±zz.z,±yv.yv,±xv.xv,±zv.zv*hh<CR><LF>

Compatible Strings with Heading:

HDG	\$--HDG,x.x,x.x,a,x.x,a*hh<CR><LF>
HDT	\$--HDT,x.x,T*hh<CR><LF>
HDM	\$--HDM,x.x,M*hh<CR><LF>

3.2.8. Data Input from an ROV

If the ROV option is selected from the `Vehicle` drop down list in `Job Setup` the `Vehicle` tab will become visible and allow further configuration.

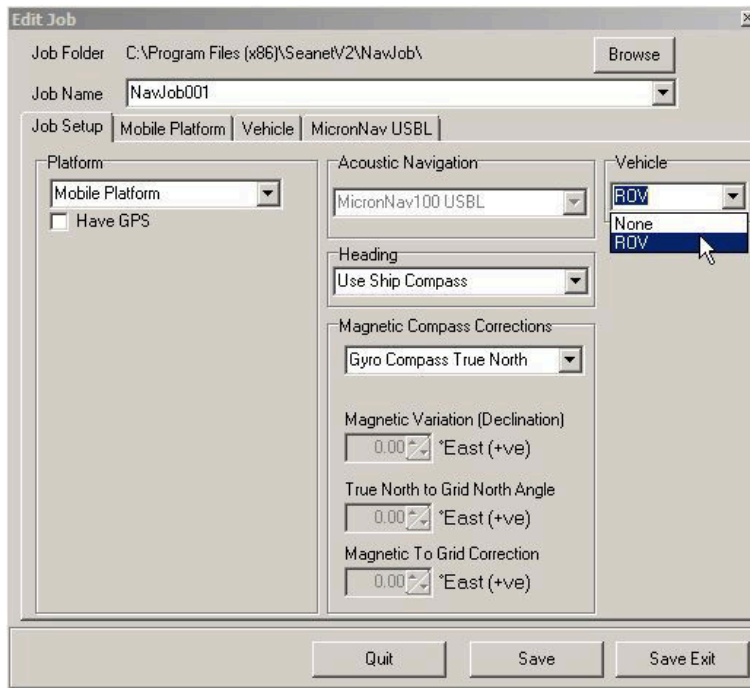

Selecting the `Vehicle` tab will bring up the following dialog:

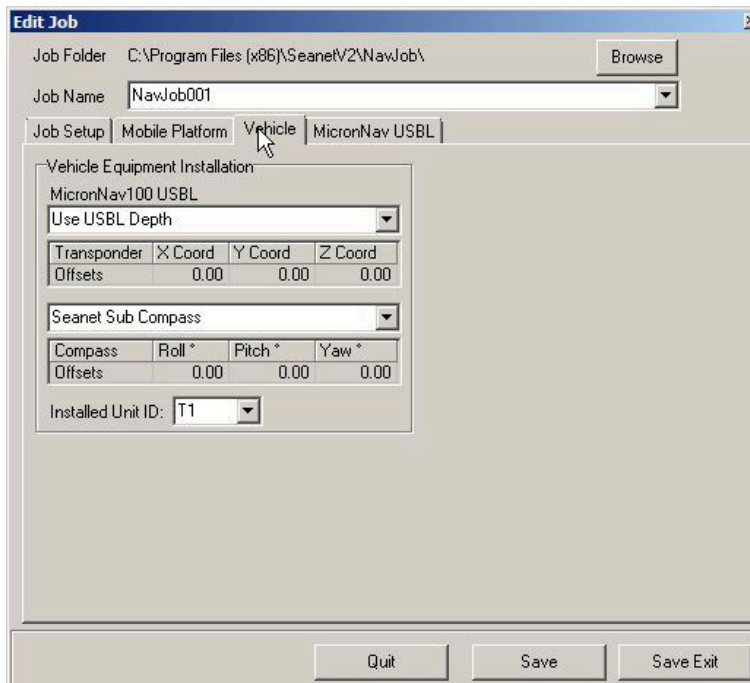

The source for the depth data for the ROV can then be configured by selecting from the drop down menu. Choose between `Use USBL Depth`, `Use Seanet Depth Gauge`, `Use SK701/704 Bathy` (if a SeaKing 700 Series (Bathy) is available on the system) or `INS Depth` (if a Micron INS is available).

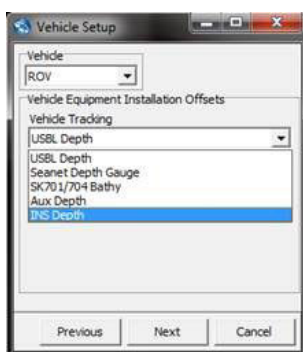

The heading can be set from the drop-down list as follows:



`Vehicle Compass`– available from any supported vehicle communication input (such as `vLBV`).

`Seanet Sub Compass` is an input device configured through the `Com Setup` dialog (`Utilities` menu -> `Com Setup`). From within `Com Setup` navigate to the `New` menu and select `Sub Compass` to add it to the available devices.

`Vehicle AHRS` – eg from `SBG AHRS Input` from the `Utilities` menu # `Com Setup`.

`Aux Compass` – from the `Aux Device Input` selected in the `Utilities` menu # `Com Setup`.

`INS Compass` – use the compass from an attached Micron `INS`.

The vehicle data from an ROV can be displayed on a chart display by right-clicking on the chart and selecting `Configuration`. From within the `Configuration` dialog it is possible to select one or more of the ROV attributes to be displayed (`Depth`, `Heading` and `Pitch/Roll`) or hide the display completely. When enabled a `Vehicle Position` display will be shown in the bottom right of the screen:





Note

If the `Vehicle` has not been configured or has been set to `None` then the `Vehicle Data Display` options will be greyed out and the data display will be hidden.



If this is the case it will be necessary to configure the ROV data by selecting `Edit Job` from the `MicronNav -> Job` menu and select `ROV` in the `Vehicle` drop down box.

3.2.9. Connecting optional third party Video Camera

The MicronNav system can be configured to accept a Video Input from an external USB Video Adaptor receiving PAL/NTSC video from a composite source and display the video in a window adjacent to the MicronNav display. (e.g. select `Sonar Nav Video` or `Nav Video` from Applications menu list, or create a new Application with Video using the Application Wizard).

The USB Video Adaptor can be connected to any of the free USB interface connectors available on the MicronNav100 Interface Hub, or any available USB interface connectors on the computer.

To configure the video and capture settings, click on the Tools icon on the left of the Video Settings Bar to open the pop-up menu which includes all the Video Application Tools.

Configuring the Optional Video Input

The Seanet SCU or customer supplied PC can be installed with an optional video input capture card. This card will receive PAL/NTSC video from a composite source and display the video in a window adjacent to other devices such as Sonar. The `Application` menu allows selection of layouts which contain a video display screen.

Video Application Tools

To configure the video and capture settings, click on the tools icon on the left of the video settings bar to open the menu:

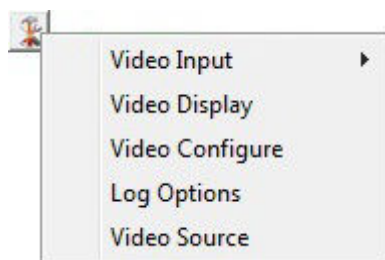

Figure 3.1.

Video Input lists the video inputs (or capture devices) that are installed into Windows. These may include internal capture cards, external USB devices and built-in webcams (if using a laptop computer).

If there is a capture device that has more than one driver installed then it may be necessary to try out the different drivers to find one that is correctly working. If there is a choice of drivers then it is recommended to opt for the driver labelled 'WDM' or 'Video' and not 'VFW'. A VFW driver (Video For Windows) is a driver that is used with older operating systems. Although it may work, the same performance will not be obtained compared with using more recent operating system drivers.

Video Display is called out from the device driver and will change according to capture device. This dialog will not always be available and will depend on the source capture device that is currently selected from the Video Input sub-menu.

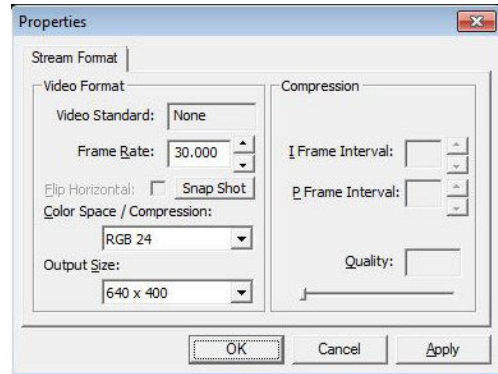

Figure 3.2.



Note

The Output Size can affect the display quality of the video preview. If the video display appears distorted try changing Color Space/Compression and Output Size to rectify (RGB24 and 640x480 are the recommended settings).

Video Configure is also called out from the device driver and will change according to capture device.

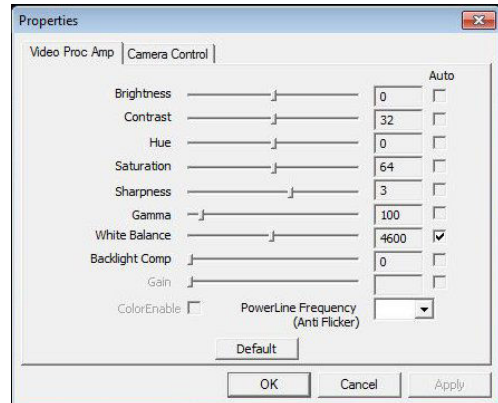

Figure 3.3.

Log Options The video footage is logged into an .AVI file format with same filename as the main Seanet Pro .V4Log log file. A frame index record is now logged into the log file which is used during playback to synchronise the video to any other sensor data that is being extracted from the log. if no other sensor data is present then video will be replayed on it's own.

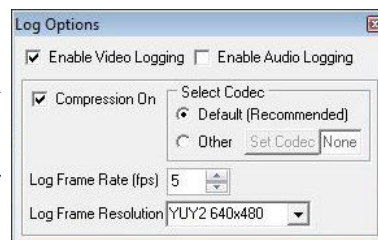

Figure 3.4.

- Tick the `Enable Video Logging` box to enable the video recording whenever a new log session is opened (by going to the `Log` menu and selecting `Record`).
- The `Log Frame Rate`, `Resolution` and `Compression` should then be configured, which will affect the video recording. A default video codec is installed which has been configured to capture good quality video at a relatively low data capacity. It is recommended that this codec be used although other codecs can be selected by selecting `Other` and clicking on `Set Codec`.
- Tick the `Enable Audio Logging` box to record audio from a connected Microphone or sound recording device. Such a device will first need to be configured and selected in Windows (e.g. Control Panel – Sounds and Audio Devices – ‘Audio’ tab page – ‘Sound Recording’/‘Sound Playback’). Audio will be sampled default at 8-bit, 11kHz, PCM format.

`Video Source`. A number of capture devices have multiple input sources. These sources can be for inputs from composite or S-VHS feeds and also from terrestrial TV stations (e.g. TV Tuner cards). It is important that the feed from the video camera (normally composite) is selected.

Recording the Video

The input video can be recorded alongside other device data such as Sonar and MicronNav. All device data is stored in the `.V4Log` log file. The video is recorded into a separate `.AVI` file which is saved in the same root folder as the log file. The AVI file will be given the same filename as that of the log file.

For example, to start recording, click on `Log` menu and select `Record` then set the filename and path for the `.V4Log` file, and the video file will automatically be created, so if there is a file named:

```
D:\Logs\Thu_14_Apr_16_07.V4LOG
```

Then video will automatically be recorded to:

```
D:\Logs\Thu_14_Apr_16_07.AVI
```

When replaying the data (click `Log` menu and select `Play`), the `.V4LOG` log file is selected and opened. If there is an associated `.AVI` file (with same filename) found in the same folder as the `.V4Log` file then it will also be opened and replayed. The playback of both files will be simultaneous and in time synchronisation with each other.

Video Capture Settings

When capturing video to a log file, there are several settings available in the ‘Log Options’ to consider. These settings will affect the quality and size of the captured video data.

It is strongly suggested that video capture using Seanet Pro is tested, and capture files sizes and rates checked and verified, before going live. The PC specification should also be adequate and a suitable capture device used to give desired performance and video quality. Any modern computer should be capable of video capture although output performance can not always be associated with a the computer specification and a clean re-installation of Windows can often release resources and improve the overall performance. If purchasing a new computer for use with Seanet Pro ensure that the storage disk to be used is capable of fast transfer speeds. For internal hard-drives SATA or SCSI should be used and externally a minimum of USB2.0 is required.

There is also a limiting factor in some video capture devices, in particular with some USB models. The capture filter for the device can often share resources for both capture and preview functions. This means that the device hardware must share bandwidth between

rendering video on the display and capturing video to file using the file writer. As a consequence of this sharing if the available bandwidth becomes over utilised then the preview function will begin to drop frames so that the capture element can maintain itself (the capture function is always given priority over the preview function). If during video capture it is seen that the video display is dropping frames (or perhaps not updating at all), but the AVI file is being written to, then it may be the capture device that is causing the fault.

Video Compression



Note

Selection of the correct codec will greatly reduce AVI file sizes.

Microsoft Windows is bundled with several video codecs. Some of these have limited functionality and limiting performance. In tests with Seanet Pro by *Tritech International Ltd* the best performance was obtained with the Cinepak® codec (developed for Microsoft by Radius).

For instance, using the Cinepak® codec can reduce video file sizes by up to 90% and more in some cases, which is very important when long video runs are to be recorded onto limited disk storage space. Using the correct codec can bring high quality video capture sizes down from 1GB min⁻¹ to under 10MB min⁻¹.

As an alternative Open Source codecs such as XVID are available. Similar to Cinepak®, XVID gives high quality and relatively loss-less video capture and remarkably small file sizes and can be downloaded from www.xvid.org. This codec could be useful if a portable solution is required, where an AVI file is to be distributed among AppleMac, Unix or Linux machines but it does require that the codec is installed on the computer prior to open and playback of the file.



Note

It is also possible to de-compress or even re-compress an AVI file post-job. A Microsoft utility named "GraphEdt.exe" is a tool that can be used to perform this task and is available from www.microsoft.com.

To enable video compression, tick the `Compression On` tick box in the `Log Options` page and then click on the `Set Codec` button to select from the list of codecs that are currently installed.

Log Frame Rate

This is the number of frames per second that is recorded to the AVI file. For capturing high speed moving object a frame rate of 25 frames per second is usually required. However, this can often be reduced to 15 or even 10 frames per second to give adequate motion coverage of moving targets underwater. The benefits of reducing the frame rate is to reduce the size of the AVI file. Also the more often the AVI is being written to then the more often the log file is written to which means that both files are being written to simultaneously. Disk transfer speeds and bus types in the computer therefore need to be capable of fast transfer speeds. SATA or SCSI solid state disks (SSD) are recommended above IDE hard drives. If using an external drive it needs to be at least USB 2.0 compliant and connected to a USB 2.0 port, and USB 3.0 or eSATA is recommended.

Video Frame Resolution

The list of available resolutions (horizontal x vertical of the video frame) will be fixed to each device type. Some capture devices will only handle specific resolutions and it is often best to use the highest resolution available to the device and then opt to apply compression and/or a reduced frame rate to keep AVI file sizes down. If the video is only going to be displayed and or screen printed in a ¼ window within Seanet Pro, then 320x240 may be sufficient.

AVI File Sizes

The video component uses DirectShow and will write AVI V2.0 files. These can be over 2.0GB in size. However, files over this size will not open in Seanet Pro and so it is strongly recommended that video capture rates are first tested before going live, and maximum recording time is then calculated to keep AVI file sizes within this limit. Seanet Pro will display a warning in the status bar when the AVI file size reaches 1.9GB and will then auto-close the file when it reaches the 2GB limit.

3.3. Remote Beacons

Overview

It is possible to receive tracked position strings from an external computer. These strings can be received through a COM port which is configured in Seanet Pro for Remote Beacon Input. The tracked positions can be displayed in the MicronNav chart, all operating alongside other device data such as Sonar and Video.



Note

A *Tritech International Ltd* device, such as a Sonar, must be running in Seanet Pro before the beacon input facility will become activated.

It is possible to input data from three remote beacons at the same time, and these are labelled as B16, B17 and B18 in Seanet Pro.

The string formats for remote beacon input that are currently accepted are:

- NMEA GGA (Latitude/Longitude only)
- NMEA GLL (Latitude/Longitude only)
- NMEA RMC (Latitude/Longitude only)
- \$PSIMSSB (East/North, Depth)
- HPR 300P (East/North, Depth)
- TP-2EC (East/North, Depth, Slant Range, Bearing)

The remote beacons are displayed in the MicronNav chart as tracked points:

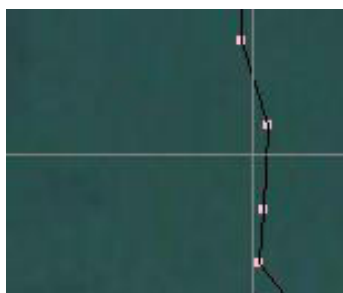

In the MicronNav display panel, the world coordinates of the beacon is also displayed, extracted directly from the input data strings:

<input checked="" type="checkbox"/> No USBL	Test <input type="checkbox"/>
No NavHub	
Rng B16	64.8m
RelBrg	230°
Depth	0.0m
No Data	
Signal Quality	
Tracked Position	
World Position	
WGS-84	
	56° 57.5710' N
	2° 11.9657' W
	0.00 Z
Ships Position	
WGS-84	
	56° 57.5969' N
	2° 11.9127' W

For relative positioning, the datum to which the beacon(s) can be referred can be either a fixed or mobile datum/reference point which is entered in the MicronNav Job Setup as a Fixed Platform or Mobile Platform:

For a mobile datum point such a ship, the ship GPS position can be input into the system, via an NMEA input string for example, and this tracked position also plotted on the MicronNav chart. If a fixed datum/reference point is to be used then its coordinates must first be entered in the Job Setup after selecting Fixed Platform. Once the job is configured with a fixed or mobile datum, the relative position of the remote beacon(s) can be calculated and displayed, i.e. Range and Bearing in the above example.



Note

If the NMEA GGA, GLL, or RMC string inputs are to be used then this will only give an XY position for the remote beacon(s). The Z coordinate can also be set if there is a depth gauge fitted on the vessel (ROV/AUV) to which the beacon position refers. This depth string can also be brought into Seanet Pro via a COM port and then configured in the Job Setup.

Job Setup	Mobile Platform	Vehicle	MicronNav USE
Vehicle Equipment Installation			
MicronNav100 USBL			
Use Seanet Depth Gauge			
Transponder	X Coord	Y Coord	Z Coord
Offsets	0.00	0.00	0.00
Seanet Sub Compass			
Compass	Roll °	Pitch °	Yaw °
Offsets	0.00	0.00	0.00
Installed Unit ID: B16			

Installation and Configuration

First ensure that there is a Trittech sensor/device connected which is required for the beacon input facility to become activated. This Trittech sensor must be connected and appear as a Node in `Seanet Setup`.

Once the device is correctly configured in `Seanet Setup`, launch the main `Seanet Pro` program and make sure that the correct application is selected (for example "Sonar Nav").

The next step is to configure a COM port for the remote beacon input. Navigate to `Com Setup` in the `Utilities` to bring up the `Channel Setup` dialog. Within the `Channel Setup` dialog the three beacons will be named `Nav Beacon B16`, `Nav Beacon B17` and `Nav Beacon B18`. If they are not present it will be necessary to add them by selecting the `New` menu and choosing `Nav Beacon`. The beacons will be added in numerical order. Use the arrows in the `COM Port` column to select the correct port on which the data is being received.

To enable a remote beacon in the MicronNav display, right-click and select `Configuration` to bring up the `Nav Setup` dialog. Within this dialog it will be possible to enable one or more of the beacons by selecting the check boxes under `Remote Beacon Selection`.

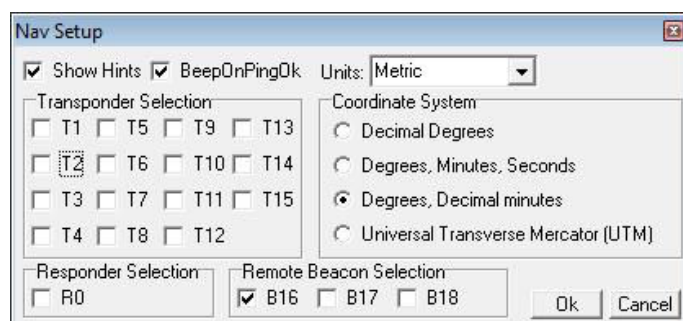

Now configure a new job in the MicronNav display. This will create a fixed or mobile datum to which the incoming remote beacon positions can be referred (to create a new job navigate to MicronNav -> Job -> Create New Job). If a job already exists it can be edited instead.

In the `Job Setup`, first select either a `Mobile Platform` (i.e., a ship) or `Fixed Platform` (i.e. for a dockside). The remote beacon positions will be relative to this position for the purpose of range and bearing calculations. For the `Mobile Platform` select `Have GPS` to enable an NMEA position string from the ship GPS and select the type of NMEA string in the drop-down list. If the GPS system can also provide a heading then select `NMEA HDT` for the `Heading Display` and select `Use GPS Heading` from the `Heading` drop down list.

If the remote beacon position refers to an ROV/AUV then select `ROV` from the `Vehicle` drop down list. Then in the vehicle setup page and ROV compass and/or ROV depth gauge can be selected with an `Installed Beacon ID`.



Note

Separate COM ports for the vehicle compass and depth gauge inputs must be configured in the `Channel Setup` dialog (`Utilities -> Com Setup`). The `Installed Unit ID` refers to the responder/transponder/beacon that the vehicle compass and depth data will be applied to.

Once job setup is complete and the remote beacon inputs have been configured the system is ready.

If ROV inputs from a compass and/or a depth gauge have been configured then the final step is to allocate a COM port for the data input. Open the `Channel Setup` dialog (`Utilities -> Com Setup`) and configure COM Ports for `Sub Compass` (ROV compass), `Depth Gauge` (ROV depth gauge) or `GPS` (ship GPS). A `Ship Compass` can also be configured if required. If the devices are not in the list they can be added from the `New` menu.

3.4. Dry System Check

3.4.1. Setting up the Application

Ensure the system has been correctly installed and configured in accordance with Section 3.2, "Installation" of this manual. Apply power to the MicronNav100 Interface Hub and click the *Seanet Pro* icon on the desktop to run the MicronNav application software, select Applications from the top menu bar of the Seanet Pro window and select the required application from the list, Sonar Nav will display the Sonar and Navigation display and would be used when operating in Responder mode, Nav will display only the Navigation display and would be used when operating in Transponder mode, if Video is also required on the display then select Sonar Nav Video for Responder mode and Nav Video for Transponder mode.

Once the display has updated with the selected application the MicronNav must be correctly configured to address the sub-sea Modem Heads being used with the system - select MicronNav from the top menu bar and select Setup Application to open the *Nav Setup* panel (if this menu option is not displayed click inside the Navigation window first), then check the appropriate check boxes for the Heads to be addressed - i.e. Responder R0 for Responder Head, Transponder Selection T1 for Transponder T1, T2 for Transponder T2, etc., or B16, B17 and B18 for remote beacons. The *Remote Beacon Selection* will be greyed out if no remote beacons have been configured for use with the system - for more details see Section 3.3, "Remote Beacons".

A maximum of 1 Responder, 15 Transponders and 3 remote beacons are supported.

The PC will make an audible beep to indicate when the system sends out a ping, this can be disabled by un-checking the *BeepOnPingOk* checkbox in this panel.



Note

If the Transponder checkboxes are greyed out then ensure that the MicronNav system is powered and installed in accordance with Section 3.2.4, "Subsea Hardware Responder Configuration" through to Section 3.2.5, "Subsea Hardware Transponder Configuration"

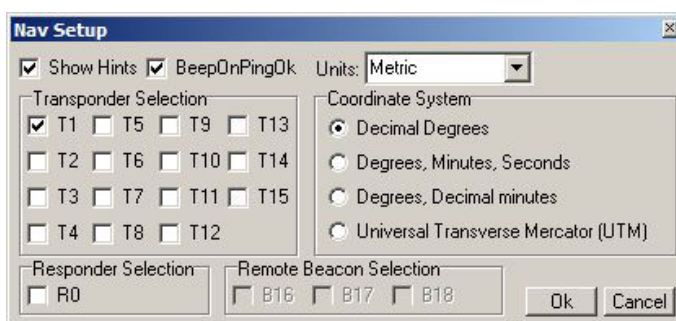

Click the *Ok* button on the *Nav Setup* panel to confirm the configuration and close the panel.

3.4.2. Transducers and integral Heading/Pitch/Roll Sensor Check

Apply power to the sub-sea installation, if a Micron/SeaSprite is installed the blue led on the front of the Sonar should light and the sonar display should start scanning and an audible chirp should be heard from the sub-sea Modem head, position the USBL Dunking Transducer next to the sub-sea Modem Head and readings of Rng, RelBrg and Depth should now be displayed on the Navigation display and the position plotted on the PPI display. If

operating in Transponder mode an audible chirp should also be heard from the USBL Dunking Transducer.



Note

The transducers will chirp at the rate determined by the update rate control at the top of the Navigation display.

If using the integral Heading & Pitch/Roll sensor take hold of the USBL Dunking Transducer and holding vertically rotate until the yellow line faces North. The Compass Heading indicator should display approximately 0 degrees. Rotate the USBL Dunking Transducer and check the Compass Heading indicator follows the rotation.

Finally, hold the USBL Dunking Transducer vertical with the yellow line facing forward and check the Artificial Horizon indicator display line is horizontal and in the centre of the circle, then move the head to simulate pitch and roll and check the horizon indicator responds accordingly.

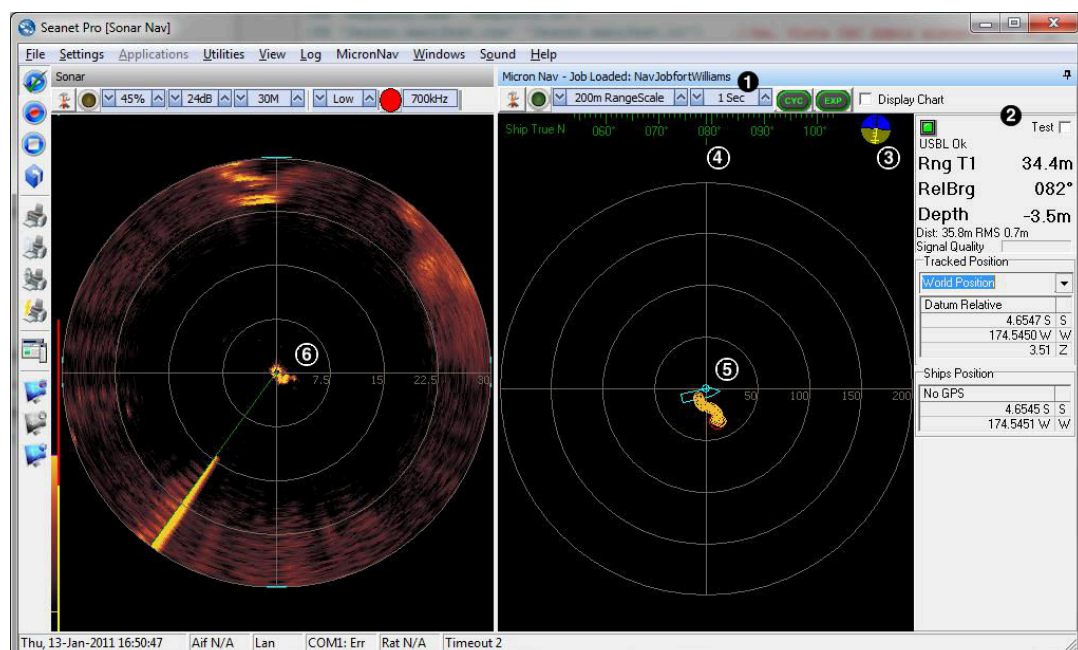

1. Update rate control
2. Rng, RedBrg & Depth readings
3. Artificial horizon
4. Compass heading
5. Head position plotted on PPI display
6. Sonar scanning

If operating in Transponder mode and the USBL Dunking Transducer is not chirping check that the USBL Dunking Transducer transmitter is enabled in the SEAHUBNAV100, this is done by selecting Applications from the top menu bar followed by Setup from the sub-menu to display the device list, then click the arrow in the SEAHUBNAV100 row followed by Setup from the sub-menu, you will be warned that this may change the behaviour of the Node, select OK to continue and the SeaHub Setup page will be displayed. Open the SeaNav100 setup panel by clicking the SeaNav100 tab and ensure the Has Transmit checkbox is checked and Receiver checkboxes Rx0, Rx1, Rx2 & Rx3 are also checked. Confirm the settings and close the SeaHub Setup page by clicking the OK button.

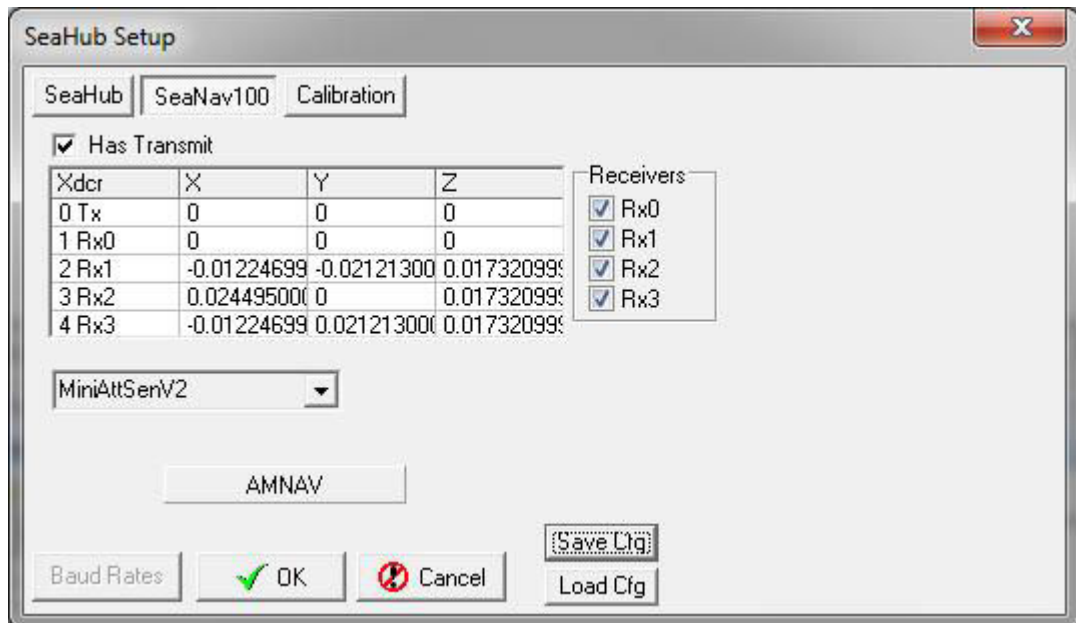

Note

Has Transmit, Rx0...Rx4 checkboxes are now only adjustable in Supervisor level. Please contact *Tritech International Ltd* Technical Support if these are disabled and need to be re-enabled.

3.4.3. Optional third party GPS Comms Check

If using an optional third party GPS Receiver check the GPS operation by selecting Utilities from the top menu bar followed by GPS Diagnostic from the sub-menu and check that GPS data is present in the GPS Diagnostics window.

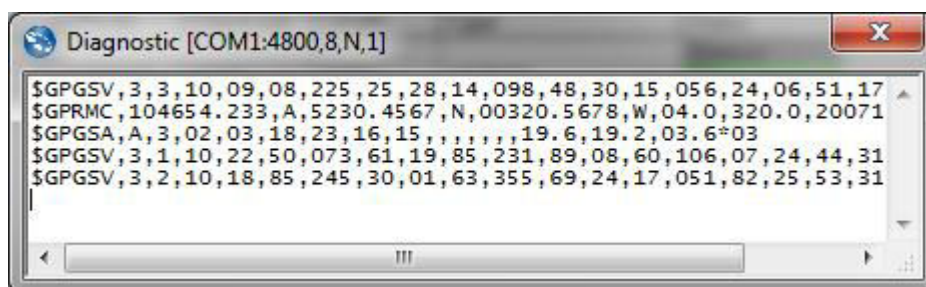

3.4.4. Optional third party Heading & MRU Check

If using optional third party Heading and MRU sensors check the compass display at the top of the MicronNav window is present and updating and check the artificial horizon box is present and updating.



Note

If these displays appear to be jumping between two positions, disable the integral sensor in the Channel setup panel (see Section 3.2.7, "Connecting optional third party High Accuracy Heading/Pitch/Roll MRU Sensors").

3.4.5. Optional third party Video Check

Check the Video communications operation by moving an object in front of the camera and ensure the picture in the video window is updating correctly and no distortion is present.

3.5. Hardware Reset



Important

The procedures outlined below involve opening the unit and appropriate precautions should be in place to protect against static discharge while carrying out this operation.

It is possible to lose communication with the surface MicronNav100 Interface Hub if the baud rate of the SeaHubMain port is taken too low (this is now only adjustable in Supervisor mode), the only way to recover from this is to perform a hardware reset on the unit to reinstate the default settings. This can only be done by opening the MicronNav100 Hub.



Caution

Before attempting this procedure ensure that the unit is disconnected from the AC and DC power source, and all other devices are disconnected from it.

Using a 2.5mm Hexagonal (Allen) key unscrew the two screws on the front panel of the unit and carefully remove the front panel assembly from the unit, the lid can then be removed by sliding forward out of its guides.

This will now give access to the DIL switch under the front edge of the plug-in daughter board, SW2 will be set to the ON position and SW1 & SW3-SW6 will be set to the OFF position. To perform the reset operation change SW1 to the ON position, re-fit the lid and front panel and apply power to the unit for about 10 seconds.

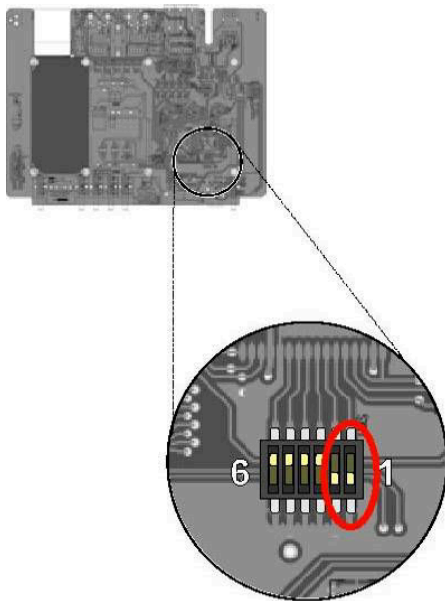

To complete the reset operation disconnect the unit from the power supply, re-open the housing as above, set switch 1 back to the OFF position and reassemble the unit. Note: If this is not done the unit will not be able to store any new settings.

This sets the SeaHubMain baud rate back to 115200Bd and reinstates communications between MicronNav100 Hub and user PC.



Note

Serial ports A – D default to RS232 so will need to be changed as required.

The USBL Dunking Transducer transmitter and receivers will need to be re-enabled in the SEAHUBNAV100, select Applications from the top menu bar followed by Setup from the sub-menu to display the device list then click the arrow in the SEAHUBNAV100 row followed by Setup from the sub-menu, you will be warned that this may change the behaviour of the Node, select OK to continue and the SeaHub Setup page will be displayed. Open the SeaNav100 setup panel by clicking the SeaNav100 tab and check the Has Transmit checkbox and Receiver checkboxes Rx0, Rx1, Rx2 & Rx3, also ensure that "MiniAttSenV2" is set in the drop down box. confirm the settings and close the SeaHub Setup page by clicking the OK button.

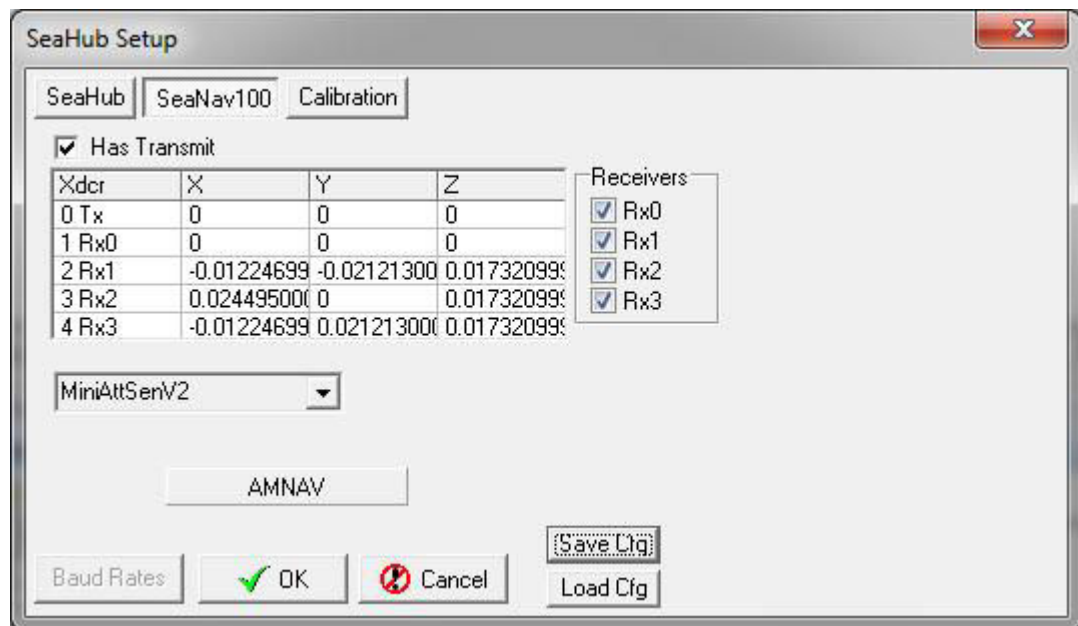

4. Operation

4.1. Mobilising the System

4.1.1. Pre Dive Checks

Prior to the system going in the water the Pre Dive checks should be carried out to ensure maximum reliability and performance from the system. Ensure the subsea MicronNav head has been mounted such that the transducer is proud of the ROV fairing with a clear view from the top, ensure the connections to the subsea Modem (and Micron/SeaSprite Sonar if fitted) are securely fastened, the blanking cap has been fitted to the AUX port of the subsea Modem head and all cables are clear of the ROV thrusters.

Power up and run the system, place the USBL Dunking Transducer next to the subsea Modem head to check the acoustic communications link is operating correctly and rotate, pitch and roll the USBL Dunking Transducer to check for correct operation of the integral Heading/Pitch/Roll sensor (if this is being used).

4.1.2. Deploying the USBL Head

The USBL Dunking Transducer can now be carefully deployed using the pre-prepared mounting arrangement (Section 3.1.3, "Mounting the Surface USBL Dunking Transducer") ensuring the head is not submerged deeper than 10 metres and the yellow line on the front of the transducer is facing in the required forward direction to ensure correct representation on the PPI display when using "Ships Head Up" display setting, if operating from a fixed platform/dockside this would normally be facing away from the platform/dockside and if operating from a mobile platform this would normally align with the front of the vessel.

4.1.3. Measuring the Installation Offsets

Once the USBL Dunking Transducer has been deployed the installation offsets can be measured and recorded for use later in the installation job setup.

When Operating from a Mobile Platform/Vessel

The reference Datum point on a mobile platform is the centre of the vessel (water level height). Starting from the datum point measure along the fwd/aft axis how far forward (+ve Y measurement) or aft (-ve Y measurement) the USBL Dunking Transducer is mounted and then measure along the port/starboard axis how far to port (-ve X measurement) or starboard (+ve X measurement), finally determine the vertical height from the datum to the USBL Dunking Transducer i.e. how deep (-ve Z measurement).

If using a GPS receiver repeat the above measurement from the datum point to the GPS antenna.

If using optional third party High Accuracy Heading/Pitch/Roll Sensors repeat the above measurement from the datum to the Sensor units.

When Operating from a Fixed Platform/Dockside

If using a GPS receiver the reference Datum point will be the GPS Antenna, if not using GPS but the latitude and longitude of a point on the fixed platform/dockside is known this can be used as the datum point, otherwise the USBL Dunking Transducer would be used as the datum point. The vertical datum would normally be water level height however if the water is tidal it is suggested the USBL Dunking Transducer is used as the vertical datum, in this case it must be remembered that the depth reading from the system would be depth below transducer and not depth below surface. If X and Y installation offset measurements are required, using a compass at the datum point to determine North starting from the datum point measure along the North/South axis how far Northerly (+ve Y measurement) or Southerly (-ve Y measurement) the USBL Dunking Transducer is mounted and then measure along the port/starboard axis how far Easterly (+ve X measurement) or Westerly (-ve X measurement), finally determine the vertical height from the datum to the USBL Dunking Transducer i.e. how deep (-ve measurement).

4.1.4. Creating a New Job (Using Wizard)

If accurate and true world positional information is required, then it is necessary to set up a Job containing all the installation offsets between each part of the navigation system as measured in the previous section.

Select MicronNav from the top menu bar (if this menu option is not displayed click inside the Navigation window first) followed by Job → Create New Job to open the 'Job Setup' window and Setup Wizard (if the Job Setup panel is too small to show the whole form then press F2 to maximise the MicronNav application).



Note

The 'Job Setup' window will not be available until the Setup Wizard is closed.

The Wizard will step the user through several screens to initially Create a Job. It will then be possible to Edit this job using the 'Job Setup' form (and also later by clicking MicronNav – Job – Edit Job).

The first screen lets the user select the Settings from a Previous/Last Job, the most Recent Job or a Blank setting to start from scratch.

Selecting 'Next' brings the user to the second page of the wizard, where the working Folder and the Name of the Job are entered.

Select a Job Folder and create a Job Name, then click 'Next'. The next page of the wizard sets up the platform. Is GPS Present? toggles the GPS options.

Platform
Mobile Platform

Is GPS Present?

GPS
Lat/Lon Display: None
Cog/Sog Display: None
Heading Display: None
Set System Time: None

Coordinate Conversion
 UTM Lat/Lon to E/N
 OSGB (from ETRS89/WGS84)
UTM Conversion
Ellipsoid: Airy
Area:

Previous Next Cancel

If the USBL Dredging Transducer is mounted to a Fixed Platform, then select this from the 'Platform' drop-down list. Now enter the Position co-ordinates for the Fixed Platform. This can be entered in Latitude/Longitude or UTM Grid formats.

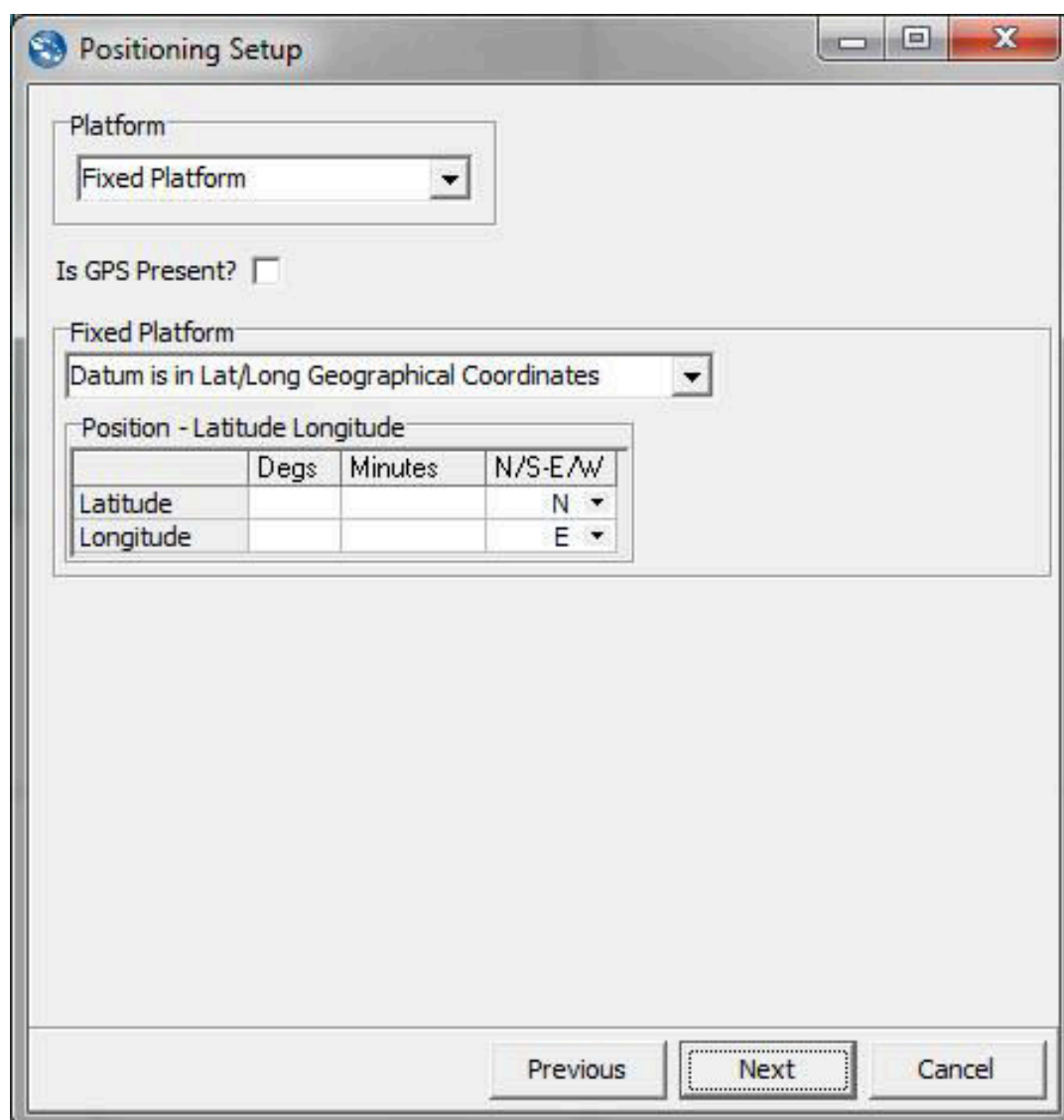

The image shows a 'Positioning Setup' dialog box with the following elements:

- Platform:** A dropdown menu currently set to 'Fixed Platform'.
- Is GPS Present?** An unchecked checkbox.
- Fixed Platform:** A section containing a dropdown menu set to 'Datum is in Lat/Long Geographical Coordinates'.
- Position - Latitude Longitude:** A table with three columns: 'Degs', 'Minutes', and 'N/S-E/W'. The 'N/S-E/W' column has dropdown menus for 'Latitude' (set to 'N') and 'Longitude' (set to 'E').
- Navigation:** 'Previous', 'Next', and 'Cancel' buttons at the bottom.

	Degs	Minutes	N/S-E/W
Latitude			N
Longitude			E

Alternatively, if there is a GPS receiver on the Fixed Platform then tick the 'Is GPS Present' check-box and select GPS message input types in the 'GPS' panel and Coordinate formats.

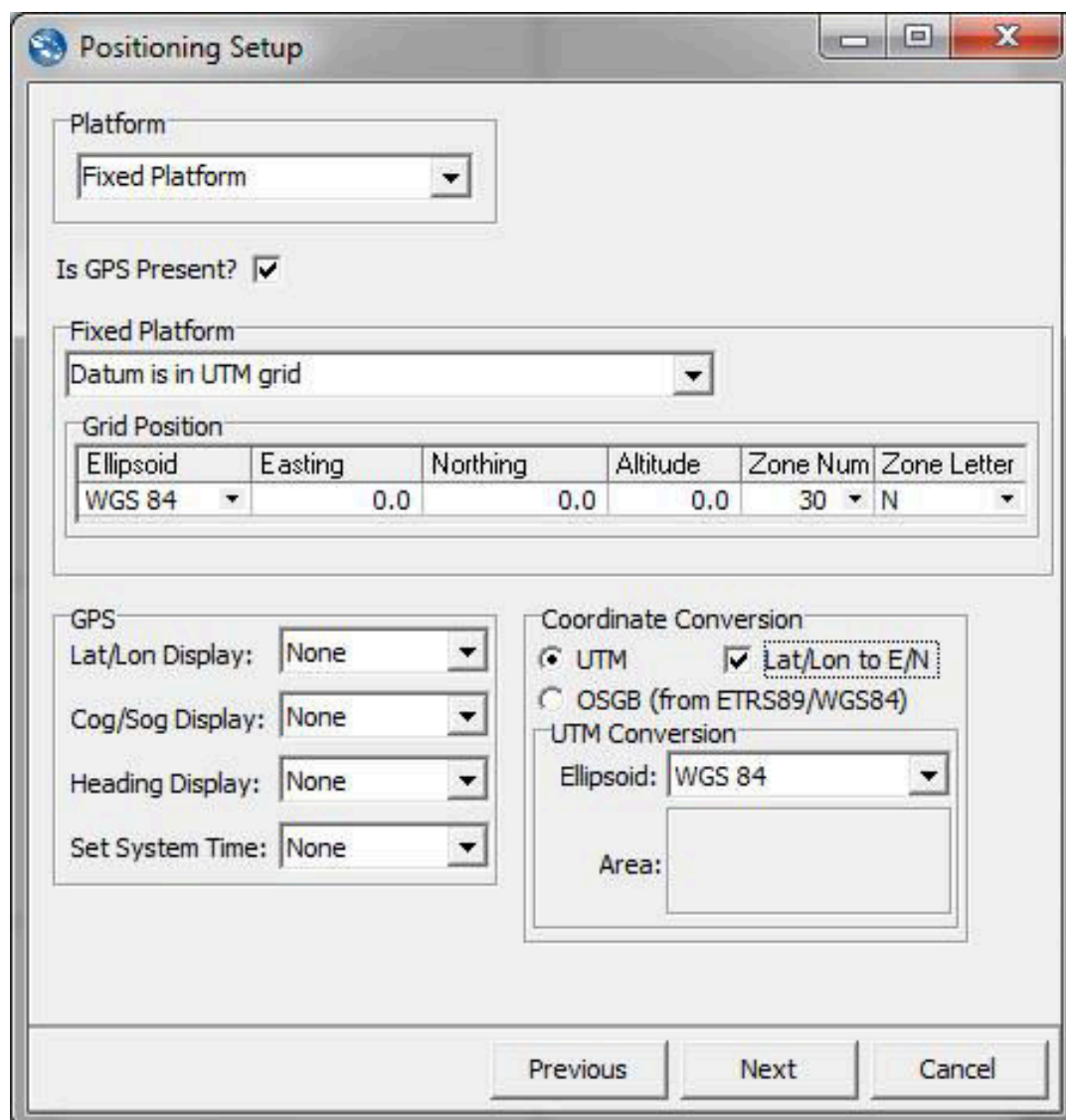

The image shows a 'Positioning Setup' dialog box with the following sections:

- Platform:** A dropdown menu set to 'Fixed Platform'.
- Is GPS Present?** A checked checkbox.
- Fixed Platform:** A dropdown menu set to 'Datum is in UTM grid'.
- Grid Position:** A table with the following data:

Ellipsoid	Easting	Northing	Altitude	Zone Num	Zone Letter
WGS 84	0.0	0.0	0.0	30	N
- GPS:** Four dropdown menus, all set to 'None':
 - Lat/Lon Display
 - Cog/Sog Display
 - Heading Display
 - Set System Time
- Coordinate Conversion:**
 - UTM Lat/Lon to E/N
 - OSGB (from ETRS89/WGS84)
 - UTM Conversion:**
 - Ellipsoid: WGS 84
 - Area: (empty text box)

At the bottom of the dialog are three buttons: 'Previous', 'Next', and 'Cancel'.

Click 'Next' when complete.

The next page of the Wizard allows the user to select a Magnetic Compass correction.

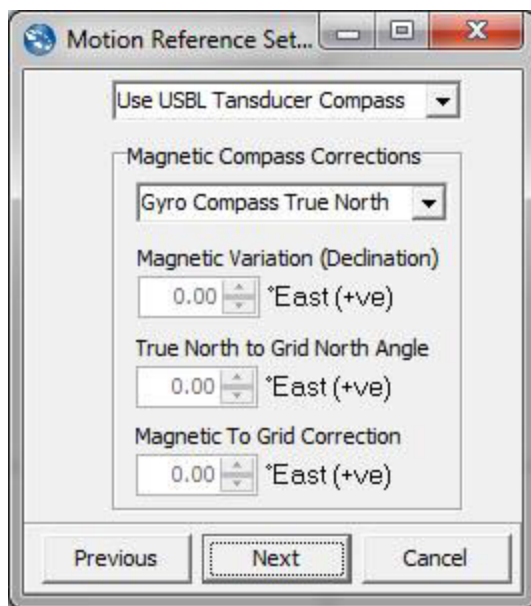

Compass Selection

The Internal USBL Transducer magnetic compass can be used (default as shown) or alternatively an external Ship Compass or GPS Heading input can be selected for use.

Magnetic Compass Corrections

This can be used to convert between True, Magnetic and Grid North depending on the Heading source and what the user requires to be displayed. This will be applied to whichever compass input has been chosen.

The next page of the wizard allows the user to set the Parameters for the Vehicle.

Seanet Sub Compass should be selected if the vehicle is fitted with a compass from which the serial data string has been brought in to Seanet Pro (this is configurable via the Utilities -> Com Setup menu). The tracking of the vehicle can be determined from the USBL depth, a Seanet Depth Gauge, or if a SeaKing Bathy is fitted to the system the data can be used by selecting SK701/704 Bathy. If a Micron INS is present it can be used by selecting INS Depth

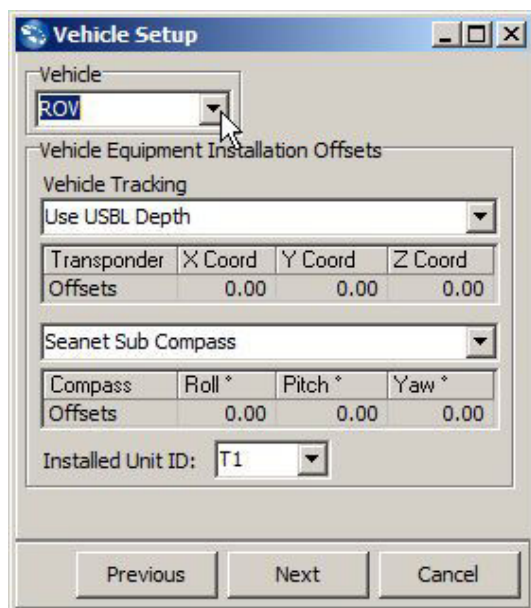

The next page of the wizard allows the user to set the Parameters for the Vessel and enter any Installation position offsets.

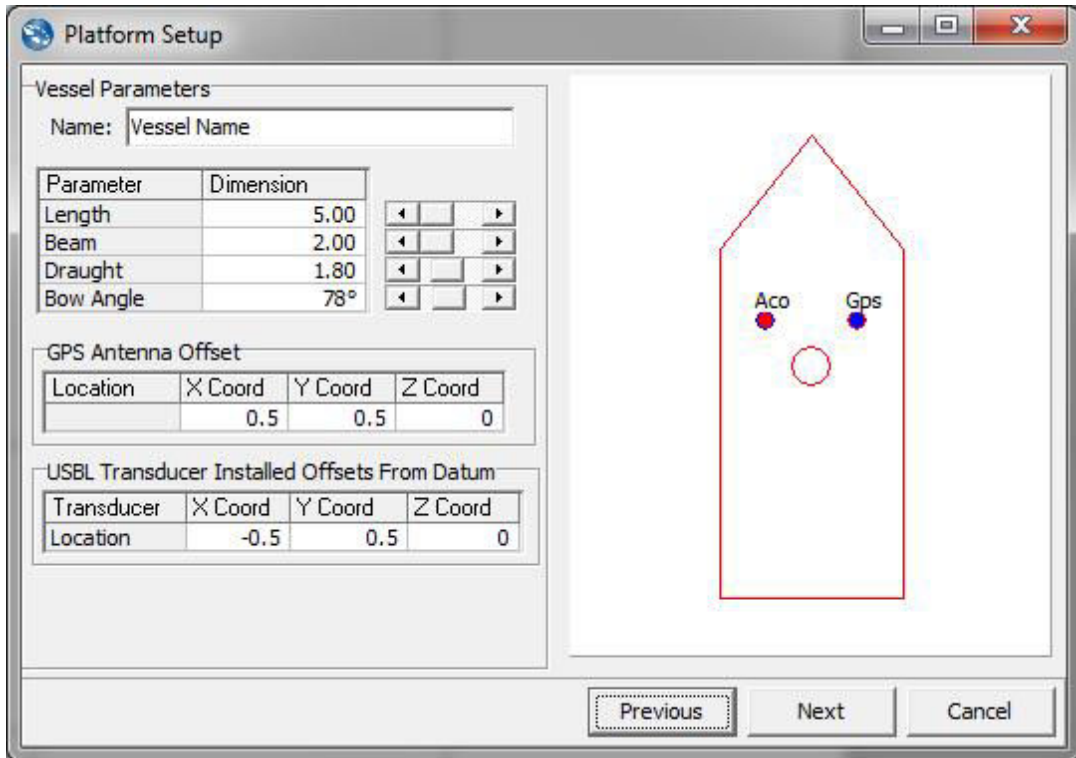

Enter Vessel details if this applies, otherwise ignore.

If a GPS is Present then an Antenna Offset can be entered to apply a position correction. The USBL Dunking Transducer installation offset should also be entered here (as measured earlier).

The last page of the Wizard lets the user set the offsets for the USBL Dunking Transducer and Attitude sensor.

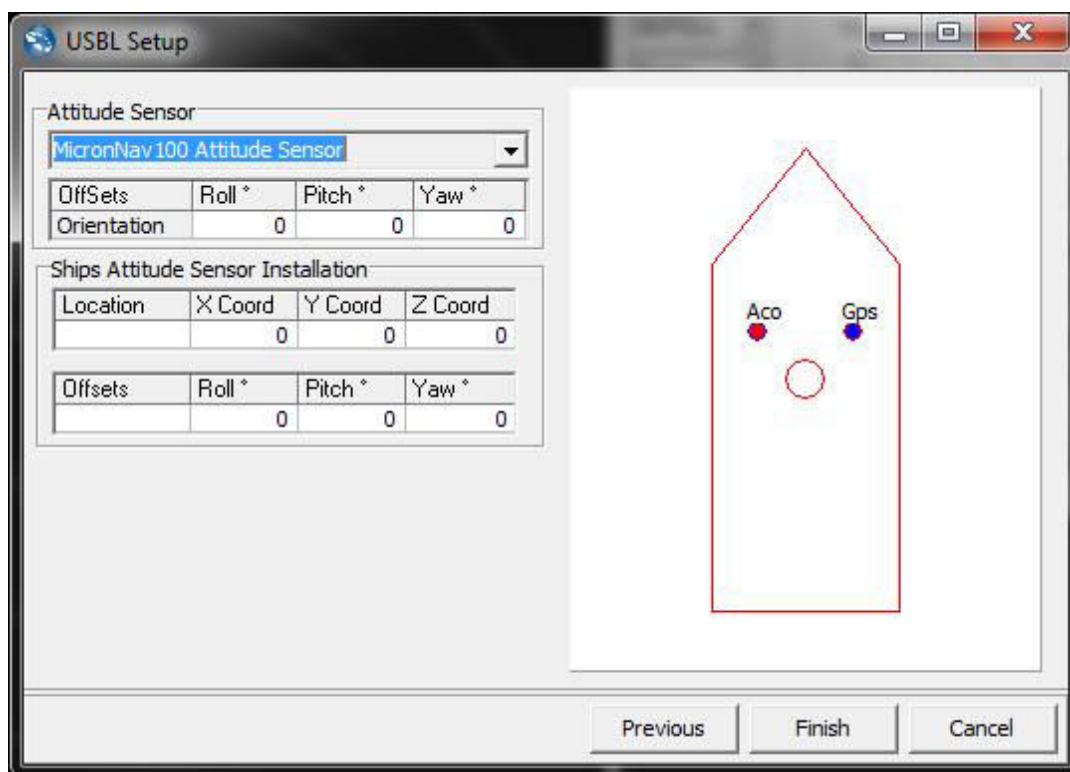

Select 'Finish' to save the settings and start the new Job, or Cancel (All settings will be lost).

4.1.5. Editing an Existing Job

If accurate true world positional information is required it is necessary to set up a Job containing all the installation offsets between each part of the navigation system as measured in the previous section.

If an existing Job exists for the operating site but some of the parameters is changed then it is possible to make changes to this Job using the Edit Job function.



Note

To retain an existing Job, but create a new Job from its settings then use 'Create New Job' and select either Use Last or Recent Job Settings (Section 4.1.4, "Creating a New Job (Using Wizard)")

Select MicronNav from the top menu bar (if this menu option is not displayed click inside the Navigation window first) followed by Job – Edit Job to open the 'Edit Job' window (if the Edit Job panel is too small to show the whole form, press the F2 key to maximise the MicronNav application).

The 'Edit Job' form is where the user can review and make changes to an existing Job.

The screenshot shows the 'Edit Job' window with the following settings:

- Job Folder: V:\W4\Seanet\NavJob\
- Job Name: NavJob008
- Job Setup: Fixed Platform | Vehicle | MicronNav USBL
- Platform: Fixed Platform
- Have GPS:
- GPS:
 - Lat/Lon Display: \$GPGLL
 - Cog/Sog Display: None
 - Heading Display: None
 - Set System Time: None
- Coordinate Conversion:
 - UTM Lat/Lon to E/N
 - OSGB (from ETRS89/WGS84)
 - UTM Conversion: Ellipsoid: WGS 84
 - User Defined Datum Shift Edit
- Acoustic Navigation: MicronNav100 USBL
- Heading: Use USBL Transducer Compass
- Magnetic Compass Corrections: Gyro Compass True North
- Magnetic Variation (Declination): 0.00 °East (+ve)
- True North to Grid North Angle: 0.00 °East (+ve)
- Magnetic To Grid Correction: 0.00 °East (+ve)
- Vehicle: ROV
- Buttons: Quit, Save, Save Exit

Normally, a default Job Folder called NavJob is created in /Program Files/SeanetV2. But other Job Folders can be selected. Click 'Browse' to open the windows browser and select other folders where the Job information is stored.

The Job Name has a drop-down list which will be populated with the names of all Jobs that are found in the current Job Folder.

When a new Job is selected from the drop-down list, the page will be populated with the Parameters loaded from this Job.



Note

Details of each Job Parameter can be found in Section 4.1.4, "Creating a New Job (Using Wizard)" and Section 4.1.7, "Job Settings for Mobile or Fixed Platforms".

If any parameters are changed then these can be applied by clicking on 'Save' (or 'Save Exit' when finished).

4.1.6. Loading an Old Job

It is possible to load up Jobs transferred from another computer or from an earlier Seanet Pro installation.

Select MicronNav from the top menu bar (if this menu option is not displayed click inside the Navigation window first) followed by Job – Load Job to open the 'Select the location of a job folder...' form where a folder can be selected that holds the Job(s) that are to be loaded.

This will open a 'Browse for Folder' form where a folder can be selected that holds the Job(s) that are to be loaded.

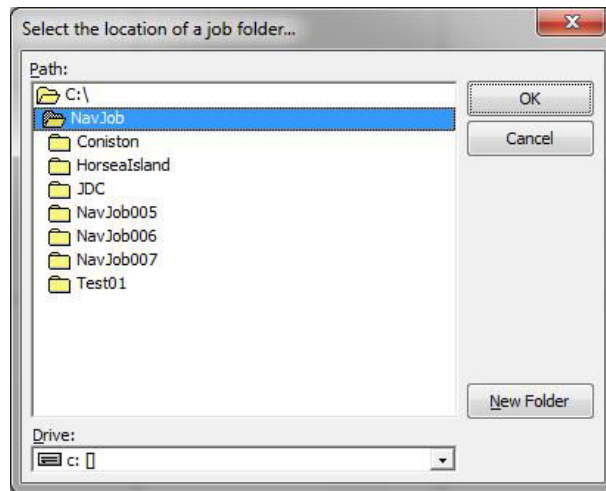

4.1.7. Job Settings for Mobile or Fixed Platforms

The USBL Dunking Transducer can be mounted to a Mobile Platform (e.g. Ship) or Fixed Platform (e.g. Dock). There are differences here in the application of GPS and Position input data and in the output data which may be in Relative or World co-ordinate formats.

The following sections explain the parameter setup options for both Mobile and Fixed Platform operation. The 'Edit Job' / 'Job Setup' Page is used as reference which is a page opened from the MicronNav – Job – Edit Job menu to preview parameters in a current or previous Job configuration.

Operating from a Mobile Platform or Vessel

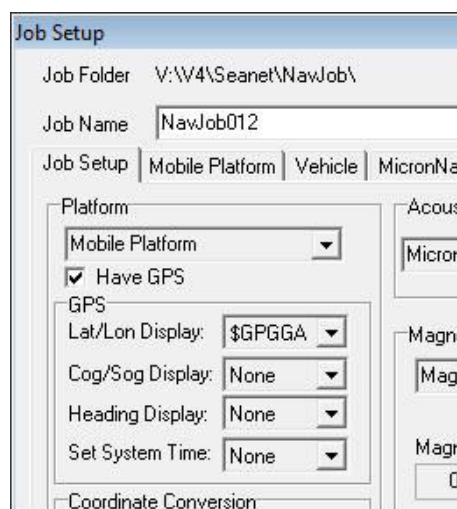

Have GPS This will display extra options and should be selected if a GPS is present

Platform If the ROV is launched from a floating platform (vessel, barge or boat) then the platform should be set to *Mobile*

GPS Allows the configuration of the external GPS system by selecting the appropriate strings from the drop-down menus. A simple setup can be

configured by setting Cog/Sog, Heading display and Set System Time to None and only selecting a string for the Lat/Lon Display as is shown in the screen shot.

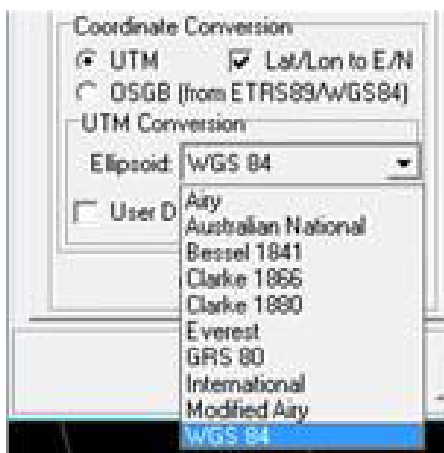

If it is necessary to display the position in Metric co-ordinates rather than Geogs, the Lat/Lon to E/N box must be checked and parameters set up accordingly. If using UTM then a range of ellipsoids are available.

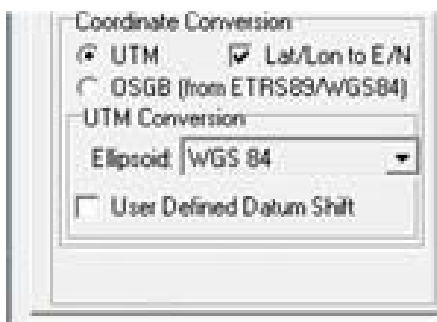

Click on User Defined Datum Shift to apply a Geodetic datum shift to the reference co-ordinates.

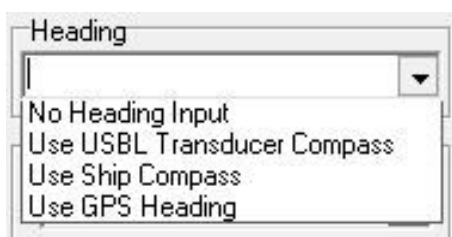

A Heading Input is used to orientate the USBL head with the ship and tie in any offsets between the GPS and Dunking transducer in order to calculate and display the world position. The source of the heading data must be selected from the drop down menu. To use the integral USBL Dunking Transducer compass Use USBL Transducer Compass should be selected. The USBL compass, however, is a magnetic type and will easily be disturbed especially if operated from a steel vessel. If the USBL compass proves unusable then an external compass should be selected by choosing Use Ship Compass. See Section 3.2.7, "Connecting optional third party High Accuracy Heading/Pitch/Roll MRU Sensors" for more details on how to configure an external compass.

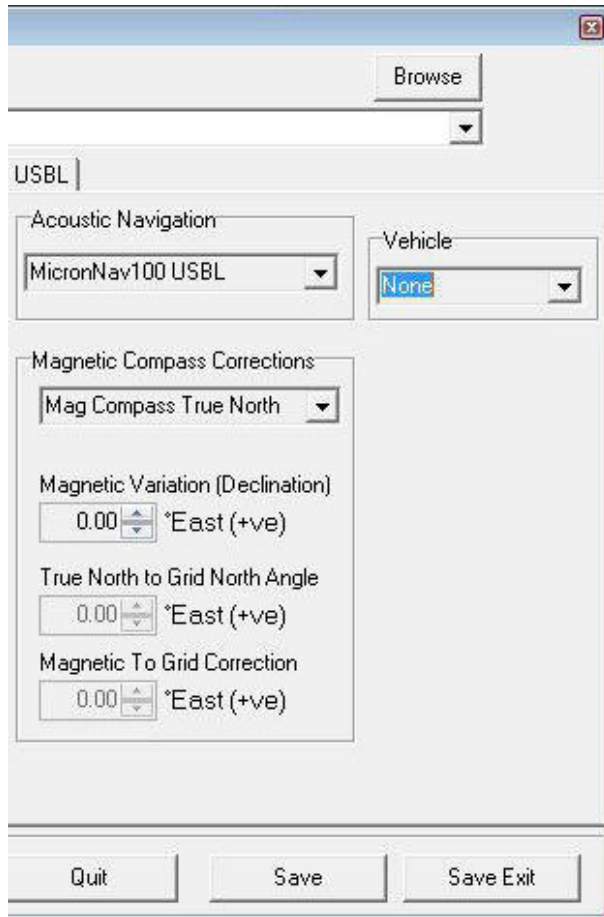

- | | |
|-------------------------|--|
| Gyro Compass True North | When using a Gyro compass and display is required to be true. No deviations are applicable, all options are greyed. |
| Gyro Compass Grid North | When using a Gyro compass this allows a deviation to be entered to allow the display to be referenced to Grid North. |
| Gyro Compass Mag North | When using a Gyro compass this allows a deviation to be entered to allow the display to be referenced to Magnetic North. |
| Mag Compass True North | When using a Magnetic compass this allows a deviation to be entered to allow the display to be referenced to True North. |
| Mag Compass Grid North | When using a Magnetic compass this allows a deviation to be entered to allow the display to be referenced to Grid North. |

Mag Compass Mag North When using a Magnetic compass and display is required to be Magnetic. No deviations are applicable, all options are greyed

Once the details have been entered on the Job Setup tab click the Save button to confirm the details and select the Mobile Platform tab. Enter the details of the vessel and any previously measured GPS Antenna and Ships Compass installation offsets on this tab.

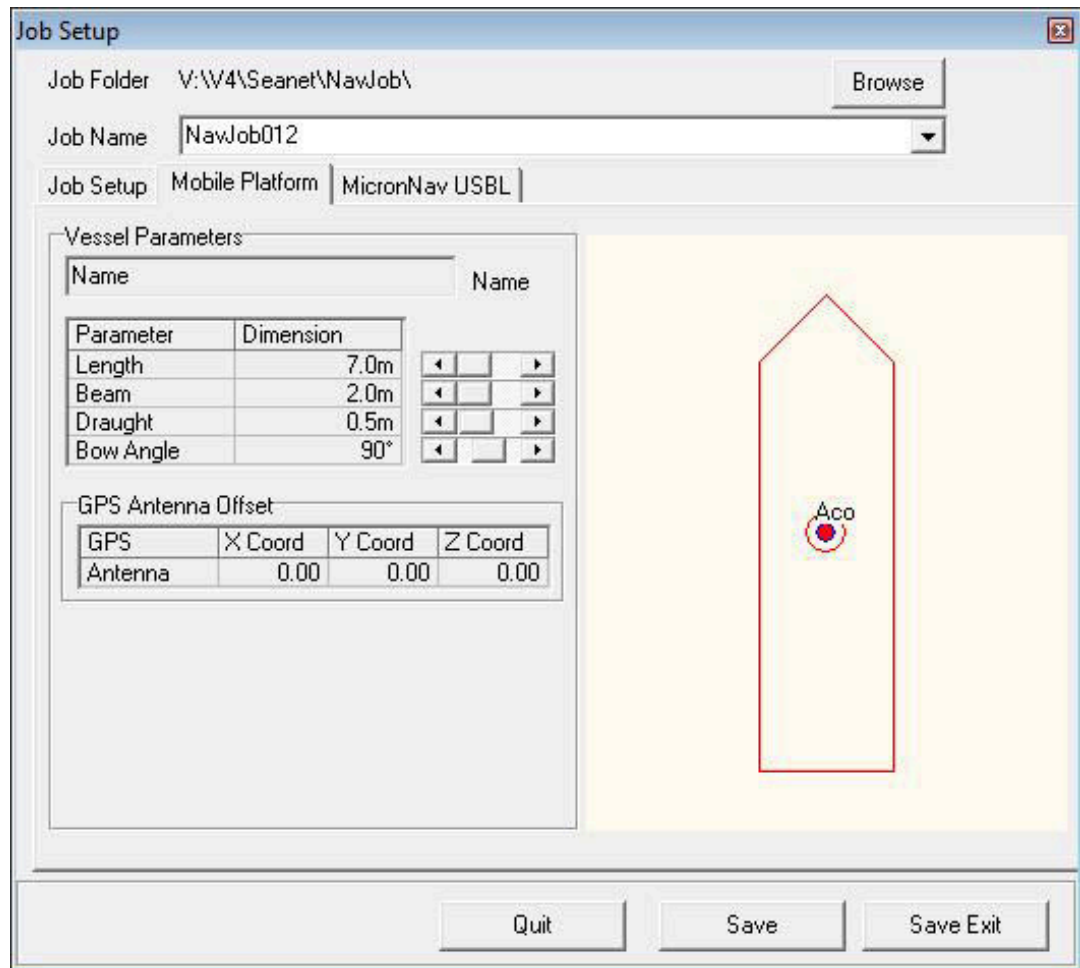

If a GPS sensor is being used enter the GPS Antenna Installation Offset measured from the transducer to the GPS antenna.

GPS Antenna Offset			
GPS	X Coord	Y Coord	Z Coord
Antenna	0.00	0.00	0.00

Once the details have been entered on the Mobile Platform tab click the Save button to confirm the details and select the MicronNav USBL tab. Enter the previously measured installation offsets of the USBL Dunking Transducer and select the source of the Pitch and Roll data.

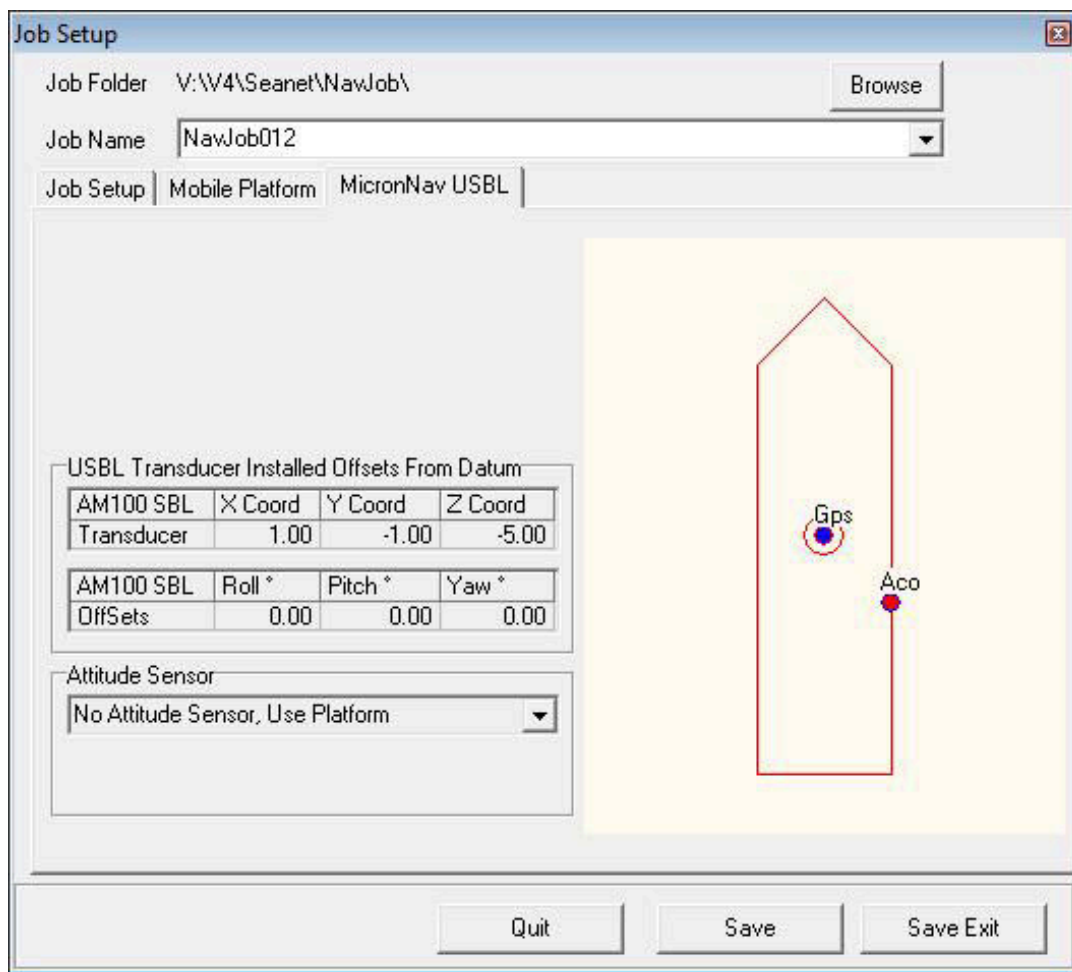

Select the source of the Pitch and Roll data, this can either be MicronNav100 Attitude Sensor (for the USBL Dunking Transducer internal sensor) or No Attitude Sensor, Use Platform if using a third party MRU sensor.

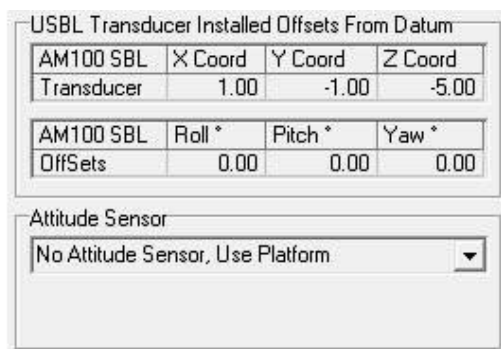

This completes the job setup for a Mobile Platform/Vessel, click on the Save and Exit button to confirm the setup and close the Job Setup window.

Operating from a Fixed Platform or Dockside

Firstly enter the details on the Job Setup tab. The details will be similar to a mobile setup and the steps from the previous section can be followed.



Note

Make sure that the Platform variable is set to Fixed Platform.

Once the details have been entered on the Job Setup tab click the Save button to confirm the details and select the Fixed Platform tab page. If a GPS Receiver is not being used but the operator knows the Latitude and Longitude of the test site (Datum point) this can be entered manually here, if a GPS Receiver is being used no entries are required in this tab as the position information will be taken from the GPS input.

Job Folder C:\Program Files (x86)\SeanetV2\NavJob\ Browse

Job Name NawJob001

Job Setup Fixed Platform MicronNav USBL

Datum is in Lat/Long Geographical Coordinates

Position - Latitude Longitude

	Deps	Minutes	N/S-E/W
Latitude	0	0.00000	N
Longitude	0	0.00000	E

Quit Save Save Exit

If this tab has been edited click the Save button to confirm the details. Now select the MicronNav USBL tab page and enter the previously measured installation offsets of the USBL Dunking Transducer and set the Pitch and Roll data source to the USBL Dunking Transducer integral sensor.

Job Setup

Job Folder V:\W4\Seanet\NawJob\

Job Name NawJob012

Job Setup Fixed Platform MicronNav USBL

USBL Transducer Installed Offsets From Datum

AM100 SBL	X Coord	Y Coord	Z Coord
Transducer	0.00	0.00	-1.00

Attitude Sensor

MicronNav100 Attitude Sensor

Att. Sensor	Roll °	Pitch °	Yaw °
OffSets	0.00	0.00	0.00

This completes the job setup for a Fixed Platform/Dockside, click on the Save and Exit button to confirm the setup and close the Job Setup window.

4.1.8. Applying a Geodetic Datum Shift to the reference co-ordinates

1. In Seanet Pro, open the 'Edit Job' page by clicking on MicronNav in the program menu and selecting Job - Edit Job.
2. If a Job has not already been created, follow the section in the MicronNav Operators manual that describes how to create this. This procedure describes how to amend such a job to apply a datum shift to reference Platform co-ordinates, e.g. if Platform is 'Mobile' then these co-ordinates will be the incoming GPS position data.
3. For a Mobile Platform, click on the 'Have GPS' tick-box and then configure the incoming GPS message type in the 'GPS' panel.

4. In the 'Coordinate Conversion' panel below that, configure this according to how position data should be displayed on-screen (and sent remotely). This can be in either Lat/Lon or Easting/Northing format. In E/N format, a UTM or OSGB projection can be performed with several Ellipsoids available for selection (with the UTM conversion).
5. Ticking the 'User Defined Datum Shift' tick-box will apply a datum correction to the incoming GPS Lat/Lon data. This will be applied in the UTM E/N data output – ensure the correct Ellipsoid is selected for this.

Example 1

In this Example, the incoming GPS WGS84 Lat/Lon position data is corrected with a Datum shift ("Aratu ES") specific to a region in Brazil (UTM Zone 24S). The output co-ordinates are Aratu ES corrected WGS84 Lat/Lon. Here is quick procedure:

In the 'Job Setup' page, the 'User Defined Datum Shift' tick-box is ticked

Edit Job

Job Folder: C:\Program Files (x86)\Seanet\2\NavJob\ Browse

Job Name: NavJob001

Job Setup | Mobile Platform | Vehicle | MicronNav USBL

Mobile Platform

Mobile Platform: Mobile Platform

Have GPS

GPS

Lat/Lon Display: None

Cog/Sog Display: None

Heading Display: None

Set System Time: None

Coordinate Conversion

UTM Lat/Lon to E/N

DSGB (from ETRS89/WGS84)

UTM Conversion

Ellipsoid: WGS 84

User Defined Datum Shift Edit

Acoustic Navigation

Acoustic Navigation: MicronNav100 USBL

Heading

Heading: Use USBL Transducer Compass

Magnetic Compass Corrections

Magnetic Compass Corrections: Mag Compass True North

Magnetic Variation (Declination): 0.00 *East (+ve)

True North to Grid North Angle: 0.00 *East (+ve)

Magnetic To Grid Correction: 0.00 *East (+ve)

Vehicle

Vehicle: ROV

Quit Save Save Exit

Clicking on the 'Edit' button to the right of the 'User Defined Datum Shift' tick-box, will open a 'User Defined Geodetic Shift' panel on top. This panel is used to enter the datum shift parameters

Edit Job

Job Folder: C:\Program Files (x86)\Seanet\V2\NavJob\ Browse

Job Name: NavJob001

Job Setup | Mobile Platform | Vehicle | MicronNav USBL

Mobile Platform

Mobile Platform: Mobile Platform

Have GPS

User Defined Geodetic Shift

Datum Name: Test

1 / Flattening: 297

Semi Major: 6378137

Delta X: 89.5

Delta Y: 93.8

Delta Z: 123.1

Rot X: 0

Rot Y: 0

Rot Z: 0.156

Scale: -1.2

Return

Acoustic Navigation

MicronNav100 USBL

Heading

Use USBL Transducer Compass

Magnetic Compass Corrections

Mag Compass True North

Magnetic Variation (Declination): 0.00 *East (+ve)

True North to Grid North Angle: 0.00 *East (+ve)

Magnetic To Grid Correction: 0.00 *East (+ve)

Vehicle

ROV

Quit Save Save Exit

After entering the datum shift parameters, click on the 'Return' button to save the settings and return to the underlying GPS panel. Configuring the Job can then continue. When finished making changes, click on 'Save Exit' on the bottom-right of the page to apply the new Job settings.

The following screen shots show the Aratus ES datum shift before and after application

A. User Defined Datum Shift = Off

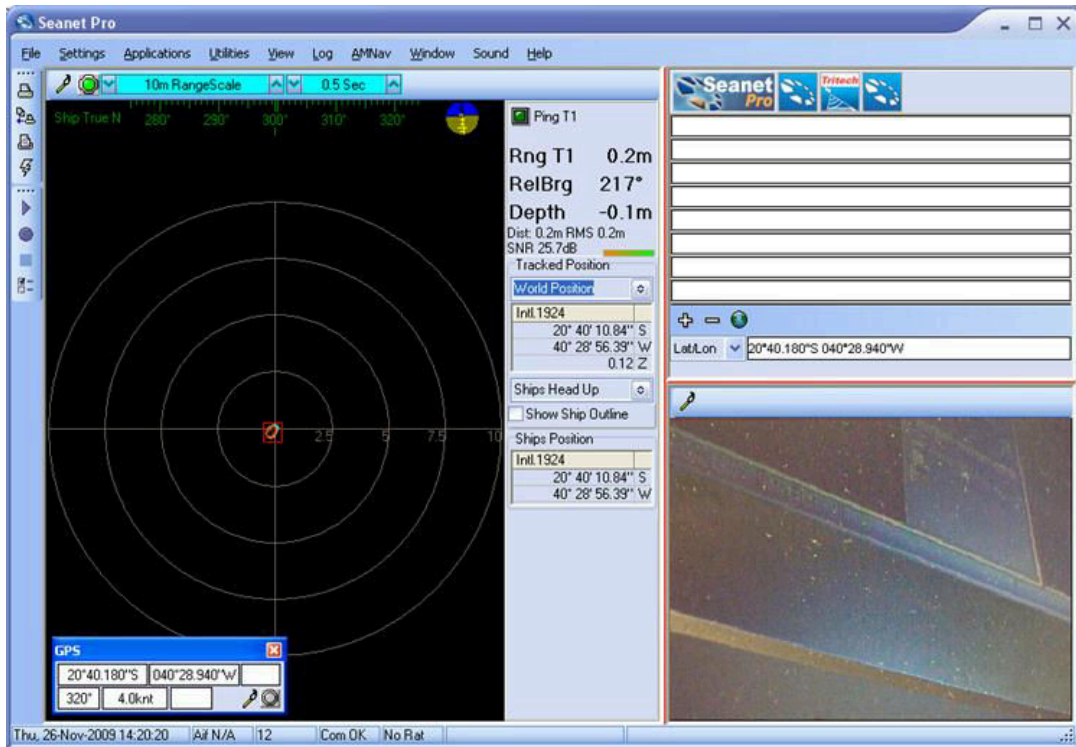

B. User Defined Datum Shift = On (“Aratus ES”)

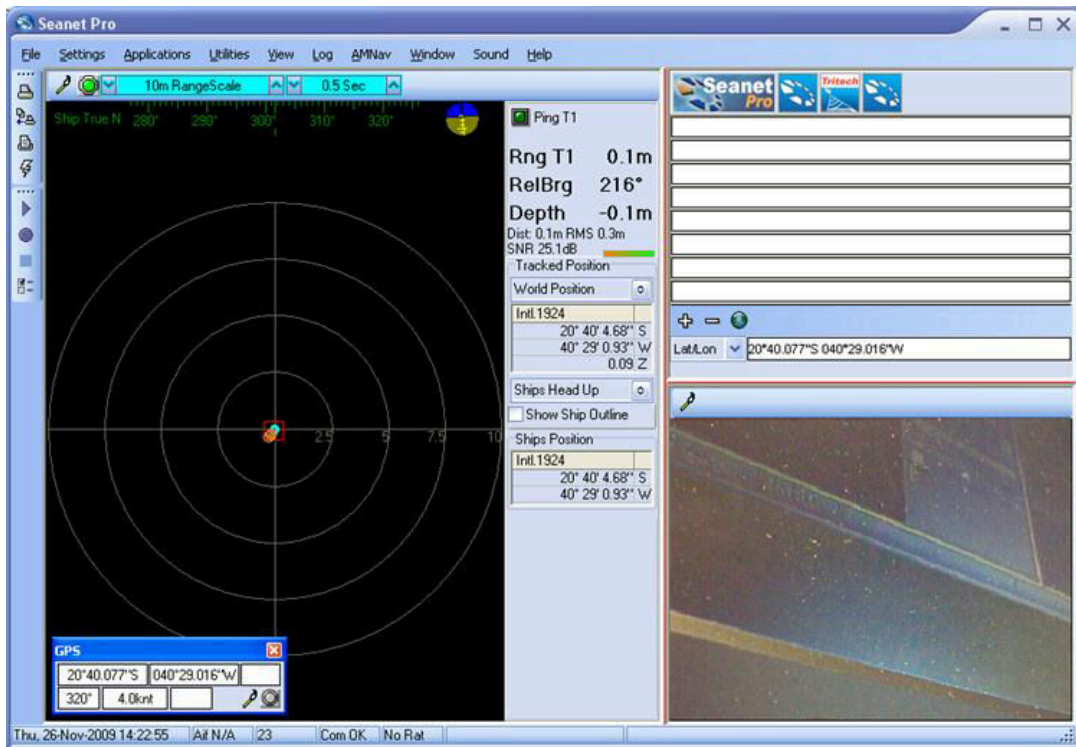

Example 2

In this Example, the incoming GPS WGS84 Lat/Lon position data is corrected with a Datum shift (“Aratu ES”) specific to a region in Brasil (UTM Zone 24S). The output co-ordinates are UTM projected using the ‘International 1924’ Ellipsoid with Aratu ES datum corrections.

In the 'Job Setup' page, the 'Lat/Lon to E/N' tick-box is ticked and the 'UTM' option button selected. The 'International' Ellipsoid is selected from the drop-down list and the 'User Defined Datum Shift' tick-box is ticked.

The screenshot shows the 'Edit Job' dialog box with the following settings:

- Job Folder: C:\Program Files (x86)\Seanet\V2\NavJob\
- Job Name: NavJob00
- Job Setup: Mobile Platform | MicronNav USBL
- Mobile Platform: Mobile Platform (dropdown)
- Have GPS:
- GPS:
 - Lat/Lon Display: \$GPRMC (dropdown)
 - Cog/Sog Display: \$GPRMC (dropdown)
 - Heading Display: None (dropdown)
 - Set System Time: None (dropdown)
- Coordinate Conversion:
 - UTM Lat/Lon to E/N
 - OSGB (from ETRS89/WGS84)
- UTM Conversion:
 - Ellipsoid: International (dropdown)
 - User Defined Datum Shift [Edit](#)
- Acoustic Navigation: MicronNav100 USBL (dropdown)
- Vehicle: None (dropdown)
- Heading: Use USBL Transducer Compass (dropdown)
- Magnetic Compass Corrections: Mag Compass True North (dropdown)
- Magnetic Variation (Declination): 0.00 *East (+ve) (spinner)
- True North to Grid North Angle: 0.00 *East (+ve) (spinner)
- Magnetic To Grid Correction: 0.00 *East (+ve) (spinner)

Clicking on the 'Edit' button to the right of the 'User Defined Datum Shift' tick-box, will open a 'User Defined Geodetic Shift' panel on top. This is used to enter the datum shift parameters.

Edit Job

Job Folder: C:\NavJob\ Browse

Job Name: Aratu Test

Job Setup: Mobile Platform | MicronNav USBL

Platform

Mobile Platform

Have GPS

User Defined Geodetic Shift

Datum Name: Aratu ES

1 / Flattening: 297

Semi Major: 6378388

Delta X: -161.11

Delta Y: 310.25

Delta Z: -144.64

Rot X: 0

Rot Y: 0

Rot Z: 0

Scale: 0

Return

Acoustic Navigation

MicronNav100.USBL

Heading

Use USBL Transducer Compas

Magnetic Compass Corrections

Mag Compass True North

Magnetic Variation (Declination): 0.00 °East (+ve)

True North to Grid North Angle: 0.00 °East (+ve)

Magnetic To Grid Correction: 0.00 °East (+ve)

Vehicle

None

Quit Save Save Exit

After entering the datum shift parameters, click on the 'Return' button to save the settings and return to the underlying GPS panel. Configuring the Job can continue. When finished making any changes, click on the 'Save Exit' button on the bottom-right of the page to apply the new Job settings.

The following screen shots show the UTM output co-ordinates which have been datum shifted.

A. User Defined Datum Shift = On ("Aratu ES"). UTM Output using 'International 1924' ellipsoid.

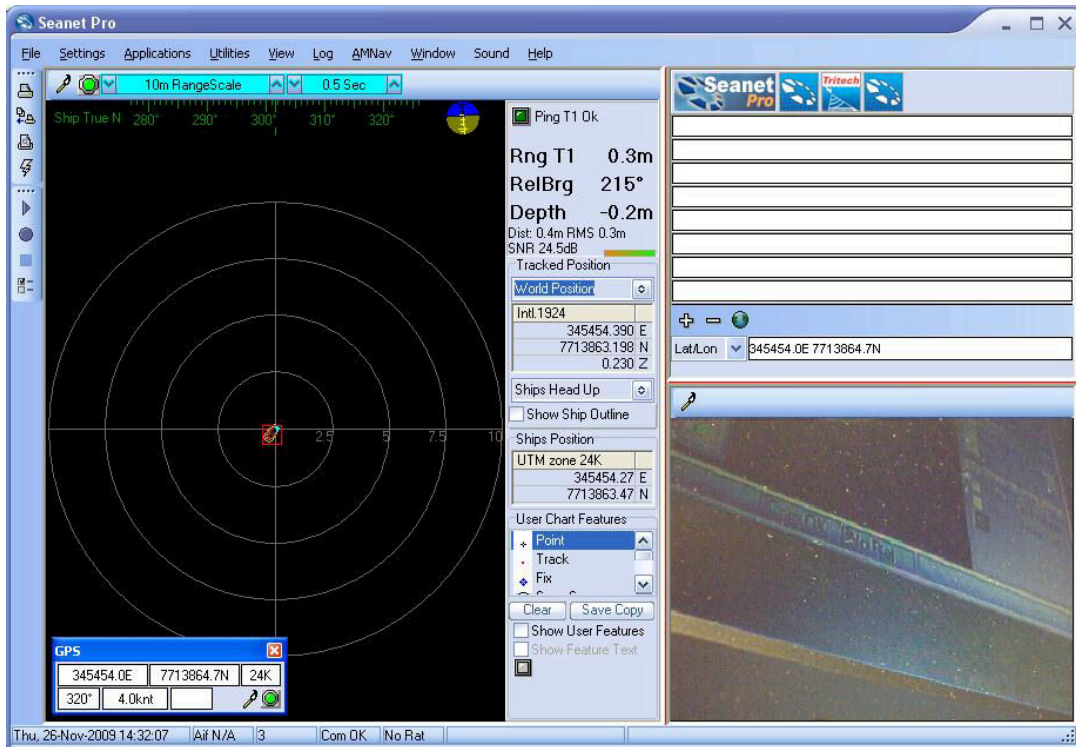

Note

Incoming WGS84 Lat/Lon position is same as used in Example 1.

4.1.9. Launching the Subsea Installation

The system is now setup and the ROV can be launched into the water. Fly the ROV around the USBL Dunking Transducer and check its position is correctly tracked on the system.

4.2. Operating the System

4.2.1. User Controls

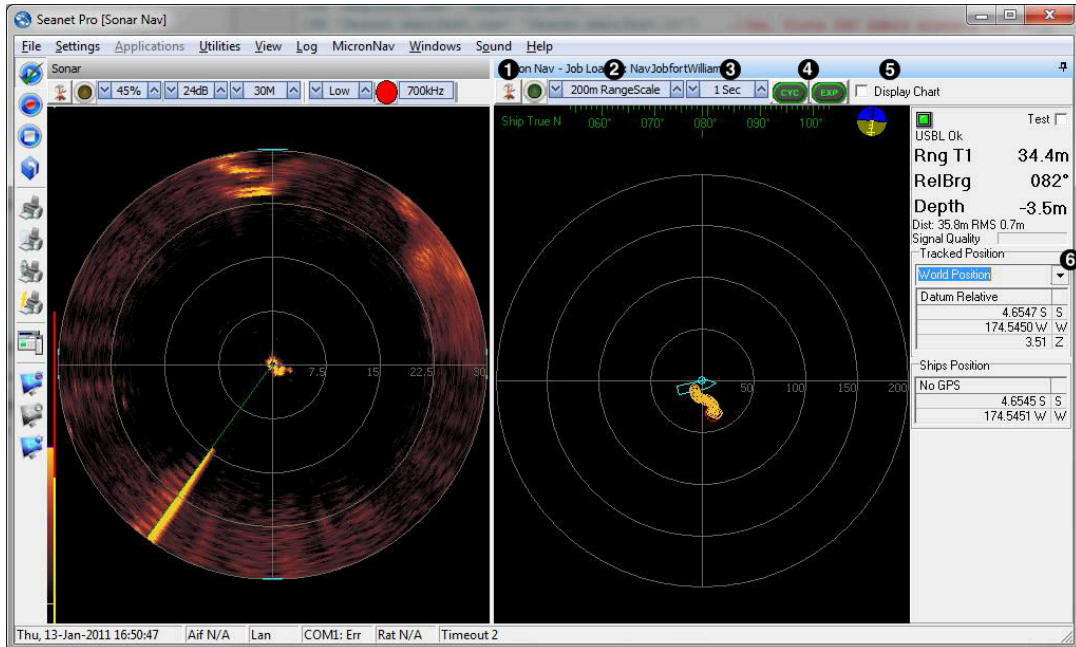

1. Click the **Tools** button to open PPI Control menu
2. Range Scale Control
3. Interrogation Rate Control
4. Cycle and Expand multi-window display applications
5. Select to display chart option. Only available if chart is registered.
6. Select Tracked Position readout as Relative position or World position

RangeScale Control

The user has control over the operating horizontal range between a minimum of 10m to a maximum of 1000m, this should be selected appropriately depending on the distance of the ROV from the USBL Dunking Transducer.



Note

The normal max operating range of the MicronNav USBL system is 500m. The controls allow for a longer range should conditions permit.

Interrogation Rate Control

The interrogation rate of the system (i.e., time between subsequent acoustic transmissions) can be adjusted between a minimum of 0.5s and a maximum of 10s, this is particularly useful when operating in a harbour type environment where multipath reflections may cause multiple positions to be displayed, increasing the time between transmissions allows time for any multipath reflections to diminish.

4.2.2. The Readings Explained

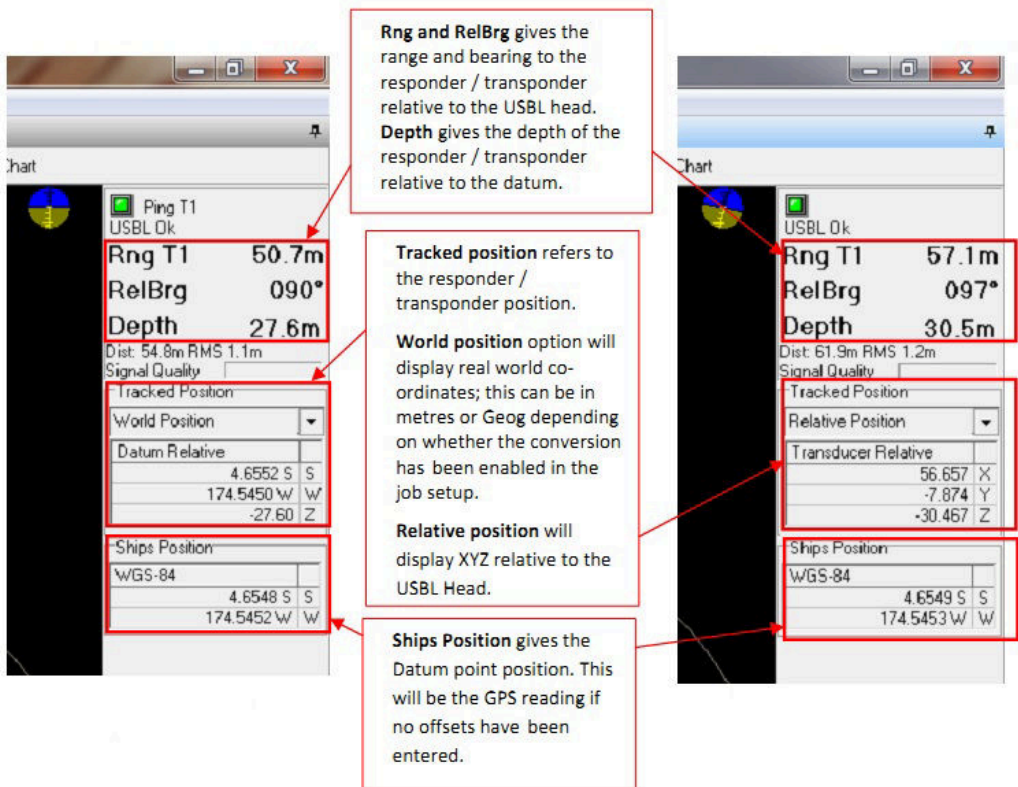
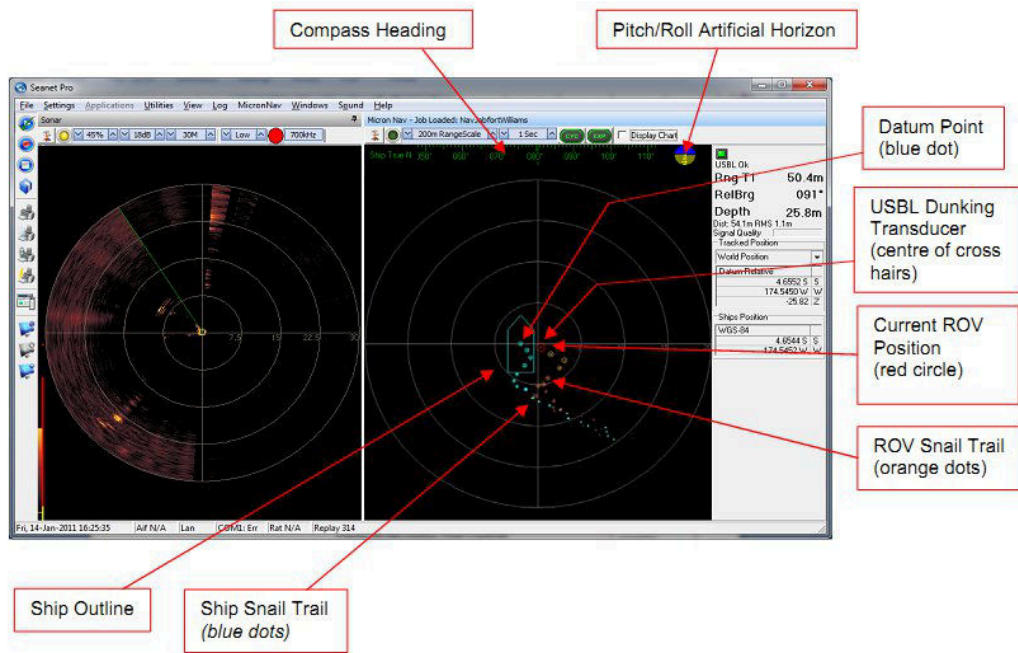

4.2.3. User Features

These are selected from a popup menu that is opened by clicking on the Tools button (or by right-clicking on the PPI display).

PPI Cursor (Position Readout)

The position of the cursor on the PPI display can be made available by selecting the paintbrush at the top of the PPI display followed by PPI Cursor from the sub-menu.

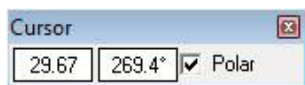

PPI Display (Settings)

The user has available several options for the PPI display format - these options are accessed by selecting the paintbrush at the top of the PPI display followed by PPI Display from the sub-menu.

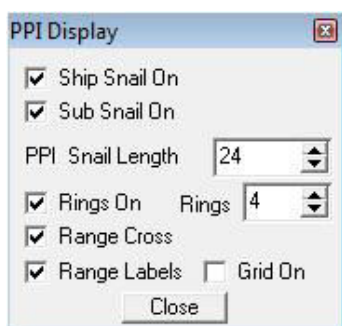

As can be seen from the captions the user can choose to display Ship Snail Trail, Sub Snail Trail, Circular rings, Range Cross, Range Labels and Grid. (In this context "Sub" refers to the tracked object or ROV) The snail trail length can be adjusted here and also the number of rings. It is suggested the user experiments with these controls to select a suitable display.

Ships Head Up / North Up

For the application of the Heading data, the PPI display can be oriented with North Up or Ships Head Up. Click on one of the menu items to select that option. Only one of these options can be selected at a time, indicated by the ().

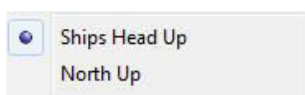

Show Ship Outline

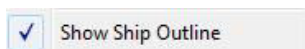

Tick this menu item to select to display a ship outline on PPI Display.



PPI Markers

To enable measurements to be taken on the PPI display the PPI Marker feature has been provided, to use this feature select the paintbrush at the top of the PPI display followed by PPI Markers from the sub-menu. Four pairs of markers are provided 'A-B', 'C-D', 'E-F' and 'G-H', each pair can be dropped on to the PPI display and provide range and bearing between each end of the pair. Select one of the pairs from the sub-menu (i.e. A-B) to open the Markers display panel, position the cursor over the first marker and left click to drop onto the display, then position the cursor over the marker, hold down the left mouse button, drag the marker to the required position and release the left mouse button to confirm its position. Repeat this

process with the second marker and the range and bearing between the two markers will then be displayed at the bottom of the marker panel.

Markers A-B		
	0.00	180.0°
	10.15	90.0°
Delta	10.15	90.0°

Marker A: Range and bearing from USBL

Marker B: Range and bearing from USBL

Range and bearing between markers

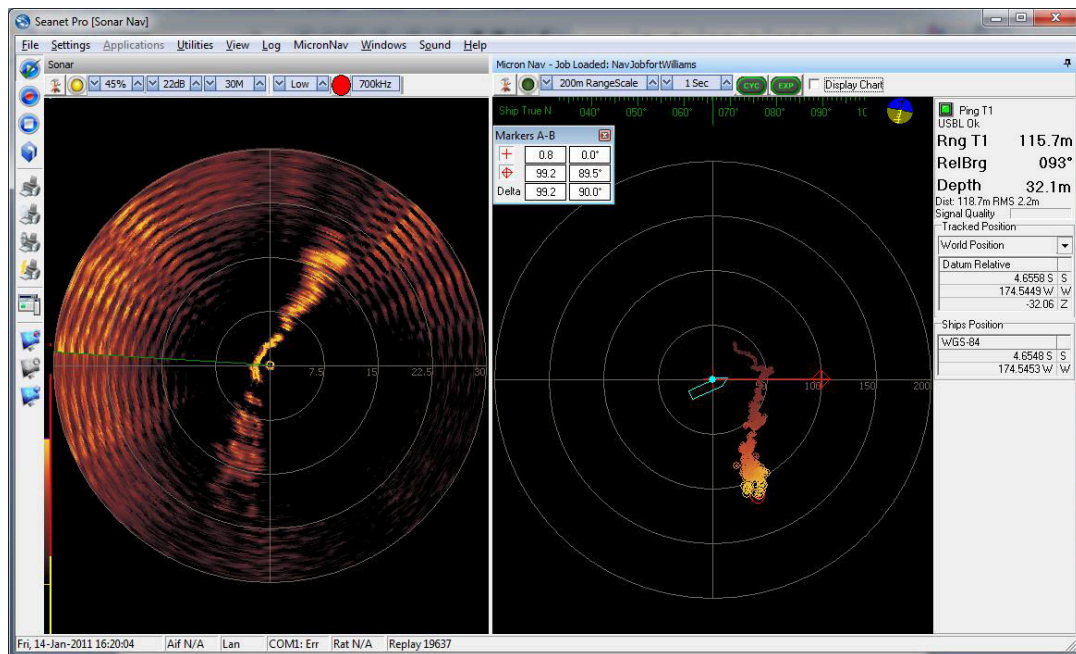

Adding Boat Marker for Chart Ship Tracking

A bitmap can be created of any boat image and copied into the Seonet application folder. This will enable an option in the Chart menu to be able to display the boat image as the ship marker. The correct dimensions of the Ship must also be configured in the MicronNav job settings.

The following procedure demonstrates the process for configuring this option in Seonet Pro V2.2.

Procedure

1. With Seonet Pro closed, a `boat.bmp` file must be placed in the Seonet application folder, within the Markers sub-folder, e.g. `C:\Program Files\SeonetV2\Markers\boat.bmp`.
2. On opening the Seonet Pro application, when this `boat.bmp` file is found, a 'Ship' item will be added to the Configuration page's drop-down list, e.g. (Right-click on Chart and Select 'Configuration')

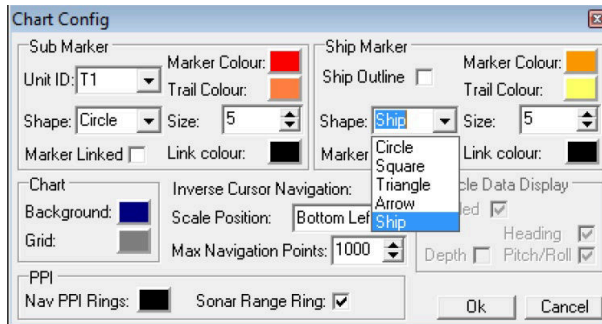

3. The boat .bmp file has the following constraints:

- a. Image must be square (e.g. 100 x 100 pixels) and can be any sensible size.
- b. Image background must be fuchsia (colour #FF00FF), e.g.

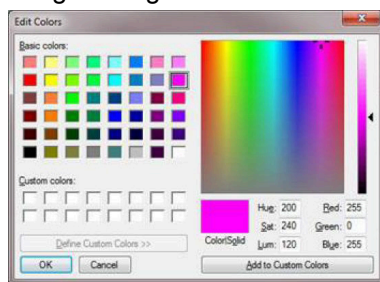

c. Bow must be top centre, e.g. as follows:



4. The scaling of the boat image will be applied from the MicronNav Job settings. As the boat image is square then only one dimension needs to be used for the scaling and this is the 'Length' value.

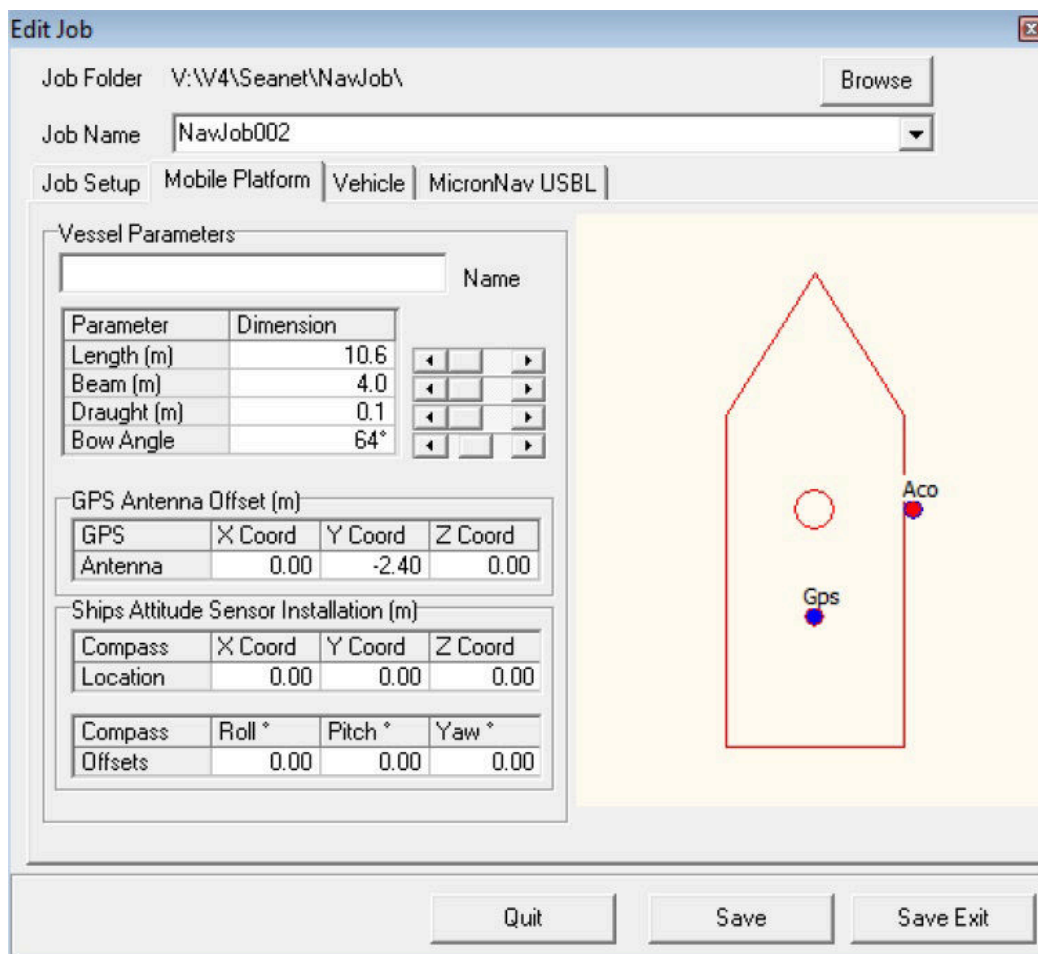

- Once complete, the boat image will appear on the chart when the ship trail is active, e.g.

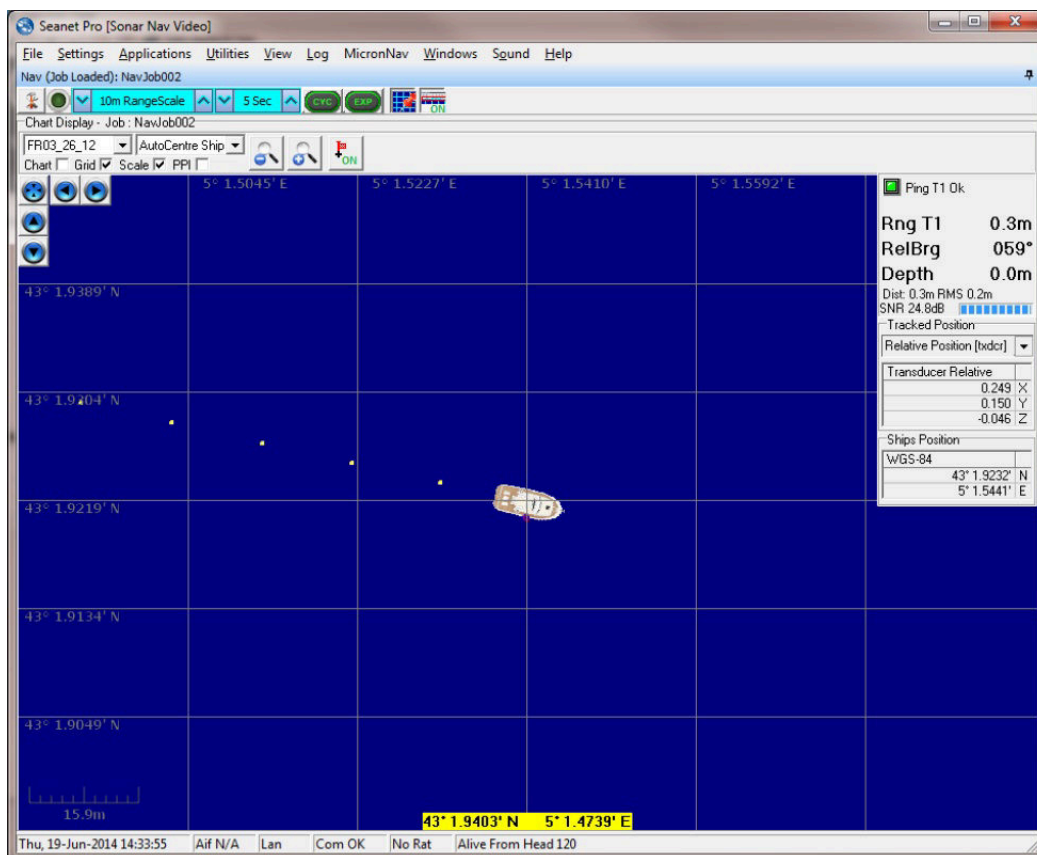

4.2.4. Other Controls

These are selected by clicking on MicronNav on the Main Menu. If this option does not appear in a multi-window application, then first click on the MicronNav display to give it the focus and try again.

The Job and Charts Setup have been described in earlier sections.

Setup Application

Click on Setup Application to open the 'Nav Setup' form. This page is where the Modem Heads being used with the system are selected. Check the appropriate check boxes for the Heads to be addressed i.e. Responder R0 for Responder Head, Transponder Selection T1 for Transponder T1, T2 for Transponder T2 etc.

A maximum of 1 Responder and 15 Transponders are supported.

The PC will make an audible “Beep” to indicate when the system sends out a ping, this can be disabled by un-checking the ‘BeepOnPingOk’ checkbox in this panel.

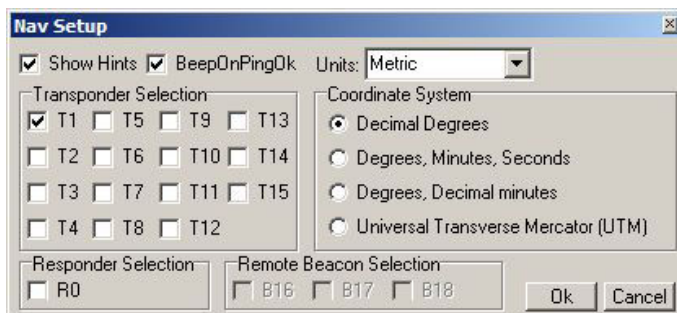

The units displayed throughout the system can be in Metres (select Metric) or Feet (select Imperial) which are available in the 'Units' drop-down list.

In the Coordinate System pane, the display co-ordinates can be adjusted to the desired format. This applies to any calculated World Position co-ordinates as well as Chart Grids and Cursor displays.

VOS (Velocity Of Sound)

Any variations in the 'Velocity of Sound' in the 'through water' transmission path can cause errors in the range measurement, these are potentially higher in Transponder mode due to the two way 'through water' transmission path. If the average sound velocity for the operating site is known this can be entered into the system, as a Job VOS, to minimise the effect. The System VOS is what is applied to all other devices in Seanet Pro and may also be the VOS that is updated if a Bathy is connected to the system. If there is not a known VOS for the operating site, then select Use System VOS (see below).

The System or Job Velocity of Sound should be visible in the panel at the top (Chart display mode) or right-hand side (PPI display mode) of the MicronNav display

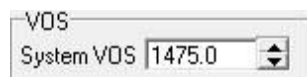
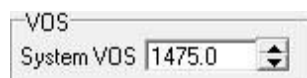
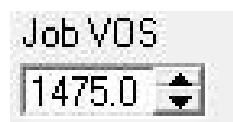

If not this needs to be set to show by selecting MicronNav from the top menu bar followed by VOS → Use System VOS / Use Job VOS. When active, a tick will appear next to the selected option.

The System VOS is read only. If this value needs to be configured it should be set in the Main Menu of Seanet Pro (click on 'Settings' – 'Environment' and edit the Manual V.O.S. value).



Note

The V.O.S. value will applied to other devices that may be connected.

The Job VOS is changeable and applies specifically to the MicronNav device. This value can be edited from the Job VOS spin-edit control on the MicronNav panel (as shown above).

Colours / Colours Setup

These are the colours that apply to the PPI display.

Click on colours to select from a list of pre-loaded colour schemes.

The colour schemes will change PPI display features such as Background, Ring and Overlay colours. These can be edited or new colour schemes created by clicking on Colours - Colours Setup.

4.3. Logging and Replay

Logging – The MicronNav data can be logged to the computers hard disk for replay at a later date. It is enabled by clicking the Log option in the top menu bar followed by Record from the sub-menu, the required directory and file name should then be selected/entered in the Log On panel now being displayed, clicking the Save button will begin the logging. Logging is disabled by clicking the Log option in the top menu bar followed by Stop from the sub-menu.

Replay – The logged MicronNav data can be replayed at any time by clicking the Log option in the top menu bar followed by Play from the sub-menu, the required directory and file name should then be selected from the Select Replay File panel now being displayed, clicking the Open button will display the Replay Form and begin replaying the data.

The speed of replay can be controlled by the slider at the right of the Replay Form panel (slider at top is fastest), replay can be paused at any time by clicking the Pause checkbox in the Replay Form panel, un-checking the Pause box will resume replay. The data can be set to continuous replay by clicking the Continuous checkbox in the Replay Form panel, i.e. when the end of the file is reached it will go back to the start and replay the file again.

Another feature of the replay is that the data can be replayed from any point in the file, this is done by pausing the replay as above, positioning the cursor over the file position indicator at the bottom of the Replay Form panel, holding down the left mouse button and dragging the position indicator to the required position, to assist the Cur readout will indicate the time and date of the indicator position. The mouse button can be released when at the required position and the Pause un-checked to replay from the new position. Clicking in the X box at the top right of the Replay Form panel will stop the replay and exit the replay function.

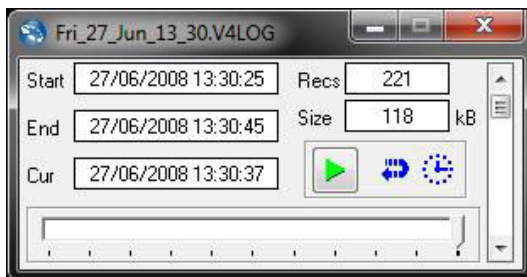

4.4. Shutting Down the System

To shutdown the system select File from the top menu bar followed by Exit from the sub menu, Windows can then be shut down in the normal way by clicking Start in the bottom left corner of the display followed by Shut Down from the sub-menu and Shut down followed by OK from the Shut Down Windows panel.



Caution

It is important to follow the correct shutdown procedure otherwise data may be lost. If for some reason the correct shutdown procedure has not been adhered to it is suggested that before the system is used again it is rebooted and immediately shutdown correctly.

5. Maintenance

Wash down with fresh water each time a unit is recovered from the water, paying particular attention to the connector areas.

Although units are designed for a wide temperature range it is best to avoid temperature extremes for long periods and protect units from bright sunlight.

Repairs are by major unit change out which may involve reprogramming a head. In these cases instructions will be supplied.

It is recommended that usage logs are maintained and that the heads are returned to the original supplier at 4000-hour intervals for routine inspection/replacement of O-ring seals.

The cables are high quality with low halogen jackets, which should provide long service life without problems. Care should be taken to ensure that they are properly sited during installation to avoid movement and fatigue, but otherwise no maintenance is required.

6. Adding and Using User Bitmap Charts

If user 'North Up' bitmap charts are available they can be loaded into the system (with scaling and position referencing) and the position of the ROV tracked and plotted on the chart. When operating on a chart the user can mark Waypoints or Objects/Targets of interest by Adding Markers, selected and configured from a predefined list, and dropping them onto the chart as required. It should be noted that this method of using bitmap charts and all associated features may be reviewed and changed at any time in future releases of Seanet Pro software.



Note

All user generated charts should be 'North Up' orientation.



Note

Charts saved in graphics formats other than .BMP (e.g. PNG, TIFF, JPEG) can also be imported.

6.1. Adding a Chart

When capturing a bitmap chart (and saving to an image format that can be imported into Seanet Pro) the user must note the following information is required to load/register the chart into the system.

- The Latitude and Longitude of the origin of the chart or the metric UTM coordinates of the corner of origin of the chart
- The metric coverage of the chart from East to West (Length)
- The metric coverage of the chart from North to South (Height)
- The ellipsoid code to be used (if using UTM coordinates)
- The UTM zone to be used (if using UTM coordinates)

Open the Chart Editor by selecting from the Main menu, MicronNav – Charts – Add Chart.

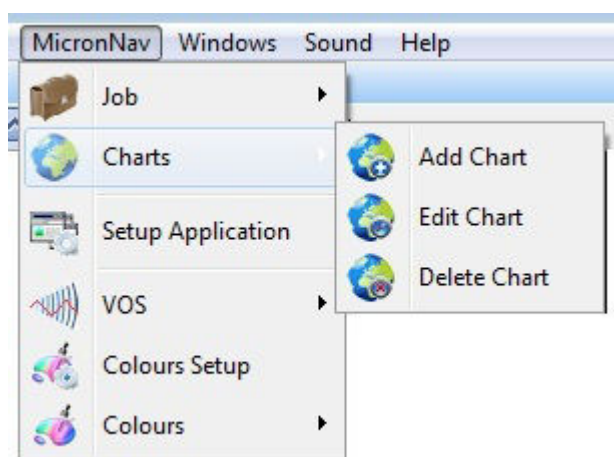

This will bring up the Create Overlay Chart editor.

In the Chart Editor, a chart/map image can be loaded which can be any of several file formats; .jpeg, .jpg, .bmp, .tiff or .tif, .png.

Once the chart/map image is loaded, geographical information (location and size) for the loaded image must then be typed in on this page. Alternatively, for backwards compatibility with earlier versions of Seanet Pro, all this information can be entered into an .INI file and this file Opened to load up all the values and populate the Chart Editor.



Note

All loaded values should be reviewed before proceeding to Save the Chart.

It is also possible to import a chart/map image which has a World File associated, e.g. which includes geographical information for georeferencing the image. The World File must have the same filename as the image file and its extension should follow standard conventions (e.g. image file = "Chart.tif", World File = "Chart.tfw"). The Dialog page used to Import the World Files has a filter that gives full information of the file extension types that are used for this.

Once all information has been entered, click on the 'Save Chart' button to save the chart information to the registry and the image file to the selected "Save To" folder. If the bitmap is stored in a different place a copy will be created in the "Save To" folder.

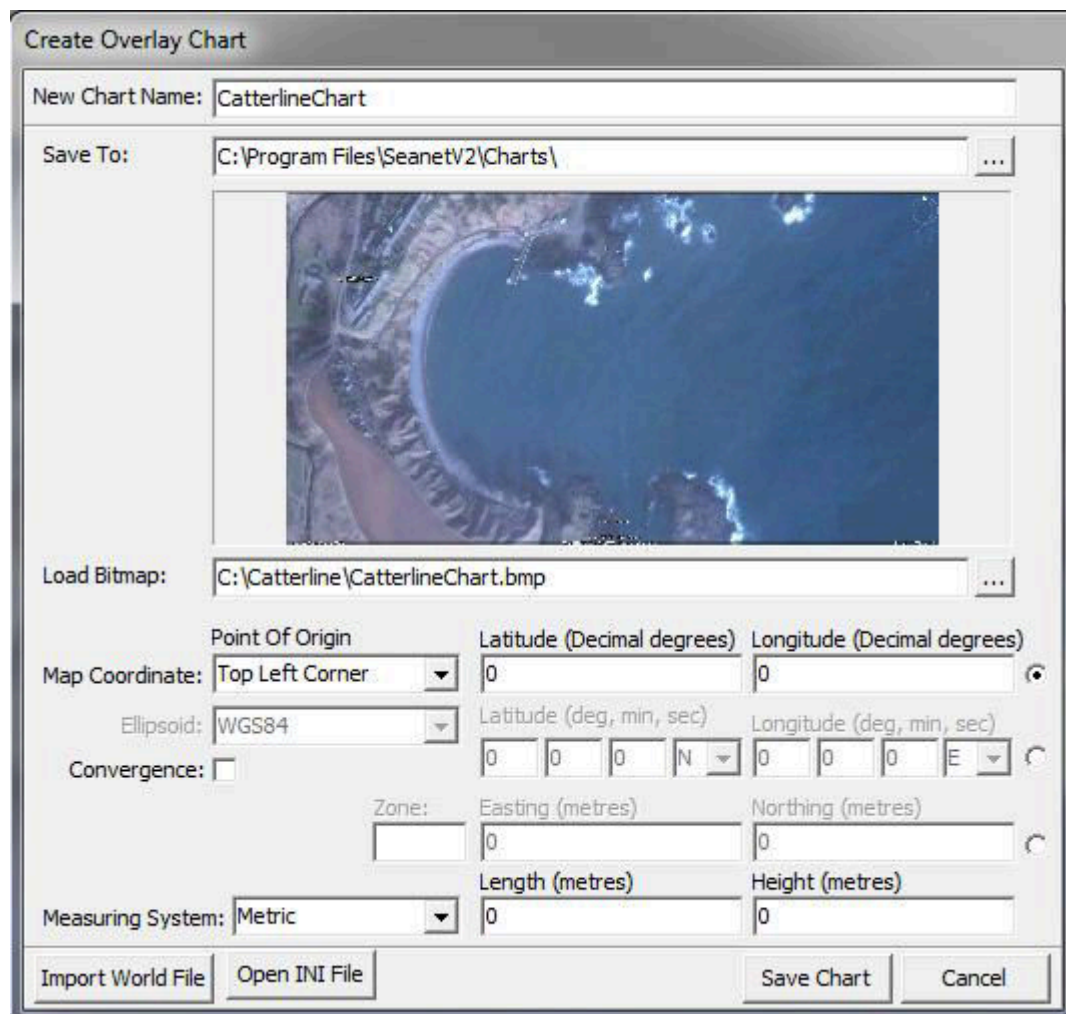

Once the Chart is Saved, it will be added to the Chart Selection drop-down list on the main page.

INI File Structure

As an example a simple bit map chart and 'ini' file have been created below, the bit map chart has been called (DockTest.bmp) and the 'ini' file called (Tritech_Ulverston_Charts.ini).

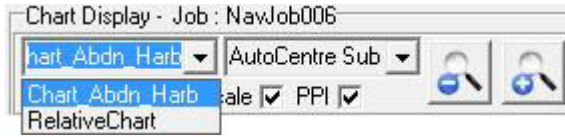
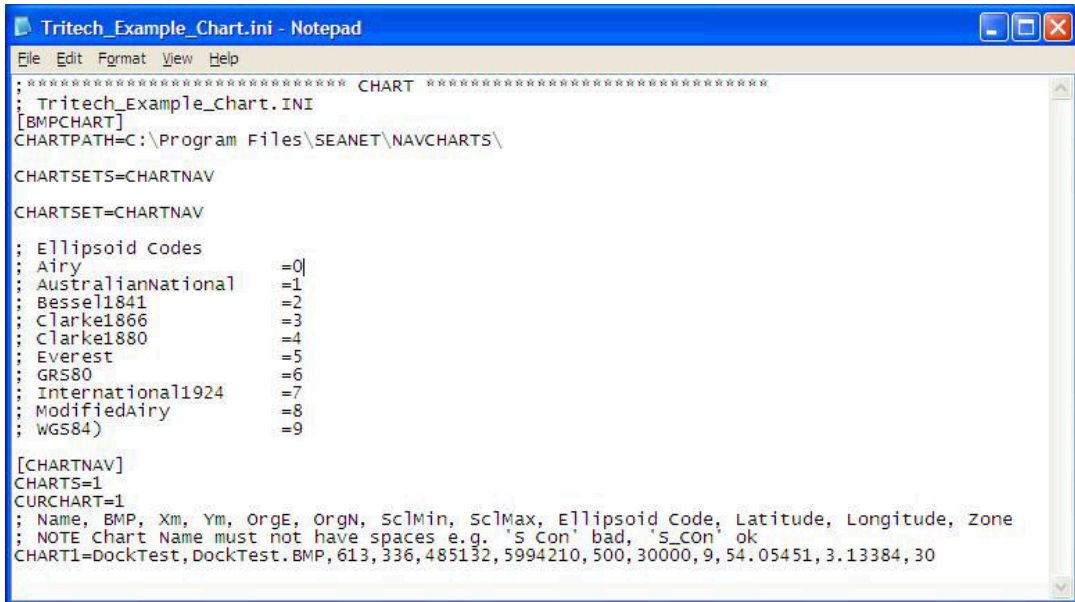
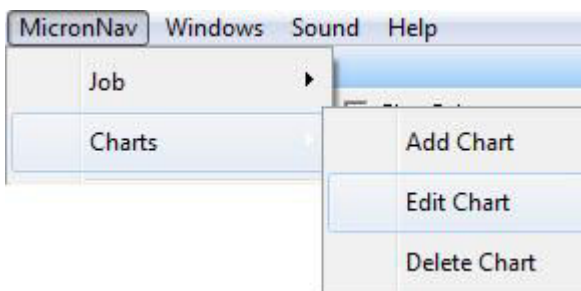

Chart details	
latitude and longitude of the lower left corner	54.05451°(N), 3.13384°(E)
metric UTM coordinates of the lower left corner	485132(E), 5994210(N)
metric coverage of the chart from east to west	613 metres
metric coverage of the chart from north to south	336 metres
ellipsoid code to be used	WGS84 i.e. code 9
UTM zone to be used	Zone 30



6.2. Editing a Chart

If a Chart has already been created and added into the system, it is possible to make changes to this at a later date. To make any edits to existing charts, Open the Chart Editor by selecting from the Main menu, MicronNav – Charts – Edit Chart.



Any edits should then be made to Chart Editor, by first selecting a chart to Edit from the 'Current Chart' drop-down list (see below) and then making changes to the loaded values.

Once changes have been made, click on the 'Save Chart' button at the bottom of the Chart Editor page. If the Chart is already selected and displayed on the main page, any changes will be made instantaneously.

6.3. Deleting a Chart

Any Chart that has been loaded into the system can be removed by selecting from the Main menu, MicronNav – Charts – Delete Chart.

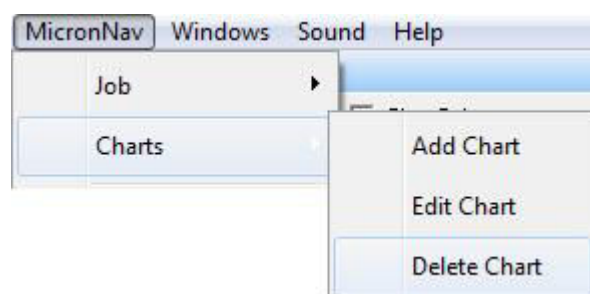

The Chart to be deleted should then be selected from 'Current Chart' drop-down list.

To remove the Current Chart, click on the 'Delete' button on the bottom of the Chart Editor page.

6.4. Chart controls

The Chart form can be displayed by clicking on the `Display Chart` icon at the top of the main form. Un-ticking this check-box will revert back to the PPI display.

Next to the `Display Chart` icon is the `ChartCtrl` icon. This control will toggle the display of all the Chart Controls, which includes functions such as Zoom Chart, Display Grid, Show Scale. If `ChartCtrl` is disabled (check-box is un-ticked) then only the Controls themselves will be made invisible and their states will remain enabled (e.g., if Show Scale is enabled, it will remain enabled).

The set of control buttons present on top of the Chart allow for the focus of the chart to be manually moved around. The arrowed buttons move the chart focus around in the direction indicated and the button with the four small arrows pointing inward will reset the focus of the chart. The button with four arrows pointing outwards allows for the chart focus to be moved around using mouse control when the left hand mouse button is held down.

The `Show Markers` button (to the right of the Zoom in/Zoom out controls) toggles the display of the markers on the chart. Markers can be added by double-clicking anywhere on the chart.

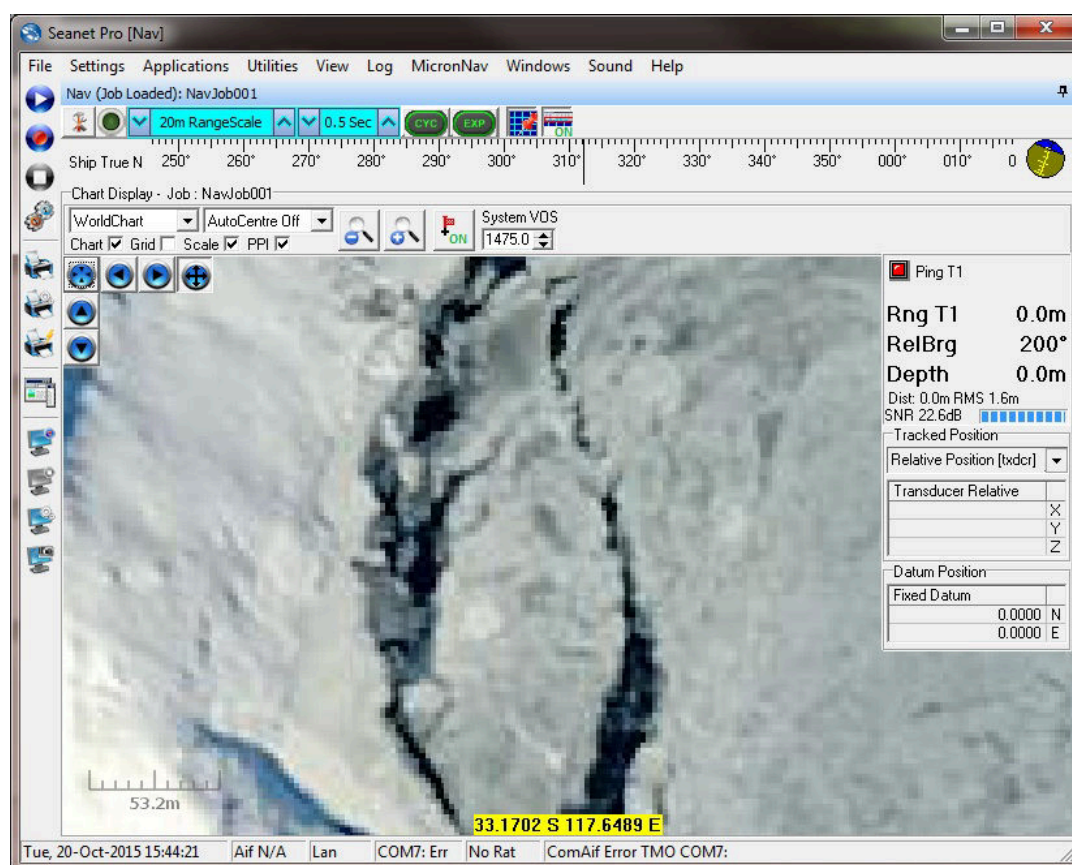

6.5. Markers

6.5.1. Overview

The Nav Chart function in Seanet Pro includes the facility to lay a series of markers to label and track objects, points of interest and way positions. These markers can be saved to file for the purpose to re-load at a later date or to form part of a report.

There are two formats of marker file:

1. A full, comma separated file format with the filename extension `.mrk`
2. A shortened, comma separated format with the filename extension `.csv`

6.5.2. Creating and Laying a Marker

Double-clicking anywhere on the chart will open the `Add Marker` dialog:

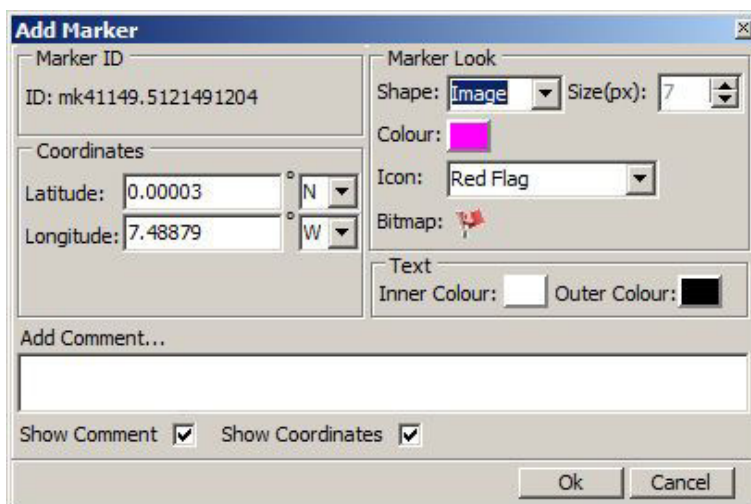

In the `Add Marker` dialog options for the maker can be configured such as; shape, image (from a preset or loaded bitmap), size, colour, font colours, comment and coordinates. Once configured, clicking on `Ok` will lay the marker on the chart.

Several markers can be created and laid onto the chart. The markers will be stored in the Seanet Pro configuration and so closing down and re-opening Seanet Pro will result in the markers being re-loaded as well.

The markers can be edited, cleared, saved or loaded by right-clicking on the chart and selecting `Markers` from the pop-up menu.



Note

To edit or delete a marker it is necessary to right-click directly over the marker.

6.5.3. Saving the Markers



Process

Right-click on the chart and select `Markers` then `Save Marker(s)`.

In the `Save as type:` drop down list the full (*.mrk) or shortened (*.csv) file formats can be selected.

Full Marker File Format (.mrk extension)

This is the format that is native to Seanet Pro and includes full details of the marker configuration. The file is in an ASCII Comma Separated format and contains the following fields:

Index	Value	Description
1	ID	This is a unique string ID. It comprises a 2 letter header ("mk") followed by a DateTime code. Any unique string value is acceptable.
2	Group	This is unused and should be set to 0.
3	X Coordinate	For the .mrk file this will always be output in UTM Easting.
4	Y Coordinate	For the .mrk file this will always be output in UTM Northing.
5	Altitude	This is UTM Altitude and is currently unused.

Index	Value	Description
6	UTM Zone Parallel	Zone latitudinal letter (e.g. 'C' through 'X').
7	UTM Zone Meridian	Zone longitudinal number (e.g 1 through 60).
8	UTM Ellipsoid	Ellipsoid code (0 = Airy, 1 = Australian National, 2 = Bessel1841, 3 = Clarke 1866, 4 = Clarke 1880, 5 = Everest, 6 = GRS80, 7 = International 1924, 8 = Modified Airy, 9 = WGS84).
9	Point Size	Applies to Circle, Square & Triangle shape types only, otherwise set to 0.
10	Date & Time	Date & Time in English(GB) Locale. Format is "dd/mm/yyyy hh:mm:ss"
11	Shape Type	0 = Circle, 1 = Square, 2 = Triangle, 3 = Sonar Range, 4 = Preset Image (see Image Info below).
12	Shape Colour	Applies to Circle, Square and Triangle shape types only, otherwise set to 00000000 (32 bit RGBA).
13	Font Inner Colour	Applies to Comment Text (32 bit RGBA).
14	Font Outer Colour	Applies to Comment Text (32 bit RGBA).
15	Marker Bitwise	Bit 1 = Show Marker, Bit 2 = Show Coordinates, Bit 3 = Show Comment Text (i.e. 00000111 = Show All).
16	Image Info	Presets = Red Flag, Blue Flag, Green Flag, Buoy, Anchor, Rock, Danger, POI, ViewPort, Sonar, Diver, Wheel, Comment or MLO Alternatively can be full path and name of an image file (e.g. 'C:\Image1.bmp').
17	Comment	Comment text.

For example, the following two markers would produce a two line .mrk file as shown:

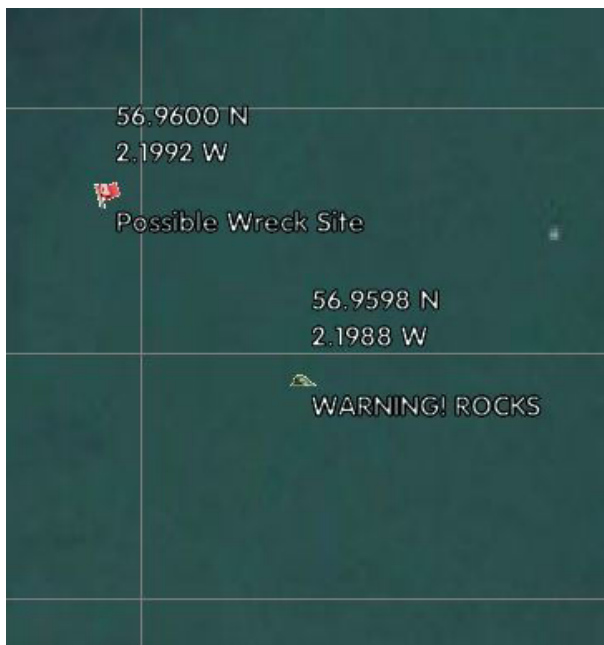

```
mk41149.5595988657,0,548699.614997778,6313221.96999907,-5.3544902067987E-76,V,30,9,0,
28/08/2012 13:25:51,4,00000000,00FFFFFF,00000000,7,Red Flag,Possible Wreck Site
mk41149.5605201736,0,548724.213265236,6313198.87994614,-5.3544902067987E-76,V,30,9,0,
28/08/2012 13:27:48,4,00000000,00FFFFFF,00000000,7,Rock,WARNING! ROCKS
```

Shortened Marker File Format (.csv extension)

This file format is a more concise and usable format, particularly for loading a pre-defined target list into Seanet Pro. The file is in an ASCII Comma Separated format and contains the following fields:

Index	Value	Description
1	ID	This is a unique string ID. It comprises a 2 letter header ("mk") followed by a DateTime code. Any unique string value is acceptable.
3	X Coordinate	For the .csv file, will be in coordinate system used in Seanet (either Longitude or UTM Easting).
4	Y Coordinate	For the .csv file, will be in coordinate system used in Seanet (either Latitude or UTM Northing).
17	Comment	Comment text.
11	Shape Type	0 = Circle, 1 = Square, 2 = Triangle, 3 = Sonar Range, 4 = Preset Image (see Image Info below).
16	Image Info	Presets = Red Flag, Blue Flag, Green Flag, Buoy, Anchor, Rock, Danger, POI, ViewPort, Sonar, Diver, Wheel, Comment or MLO Alternatively can be full path and name of an image file (e.g. 'C:\Image1.bmp').
10	Date & Time	Date & Time in English(GB) Locale. Format is "dd/mm/yyyy hh:mm:ss"

For example, the following two markers would produce a two line .csv file as shown:

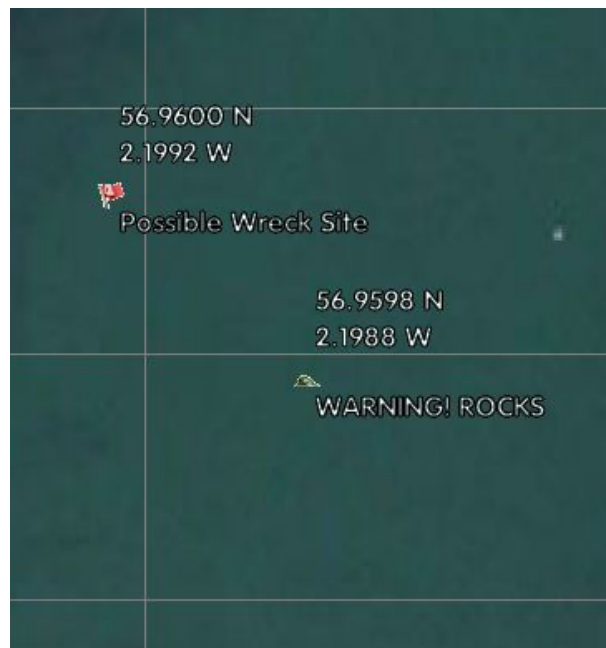

```
mk41149.5595988657,-2.1991799999203,56.9600300036883,Possible Wreck Site,4,Red Flag,
28/08/2012 13:25:51
mk41149.5605201736,-2.19877999992026,56.9598200036882,WARNING! ROCKS,4,Rock,
28/08/2012 13:27:48
```

6.5.4. Loading the Markers



Process

Right-click on the chart and select **Markers** then **Load Marker(s)**.

In the drop-down list on the right, select to list *.mrk, *.csv or both file types. Browse to the marker file to be opened, highlight it and click **Open**.

If a full format .mrk file is to be opened, it is recommended that this be in the state as saved from Seanet Pro (i.e. no subsequent modifications have been made to the text file). The .mrk file format is a native format and any slight modifications or errors to this format will not be handled.

for loading/importing as a list of targets from another system, it is recommended that the shortened .csv format be used. There are several variations to this format that can be handled.

Shortened .csv file variations

Seanet Pro can handle several variations of the shortened .csv file format.

All field data	All 7 fields contain data as normally created when Seanet Pro saves the .csv file.
First 4 fields only	There is no entry for Shape, Image Info or Date & Time. Since no shape data is available all the markers will use a red flag.
First 5 or 6 fields only	No Date & Time entry, also, if the Shape Type is 0, 1, 2 or 3 then the Image Info entry can be omitted (since there will be no need for it).

6.6. Other Chart Functions

These are selected from a popup menu that is opened by clicking on the **Tools** button (or by right-clicking on the Chart display).



Note

When the Form is toggled between displaying a Chart or the PPI form (e.g. 'Display Chart' check-box toggles this), the **Tools** button will be populated with different options in Chart and PPI display modes.

Configuration

Clicking on 'Configuration' will open the Chart Config page.

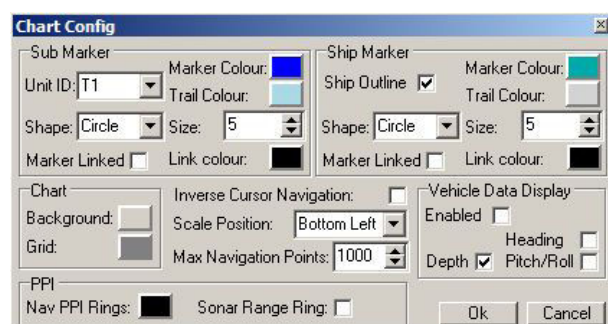

This page contains a number of options for configuring the Chart and some of its functions. These are:

Sub Marker	This is the Marker and its trail that is laid to indicate the current position (Marker) of the Responder/Transponder and its past whereabouts (Trail). The Colour, Shape and Size of this Marker can be changed and also all points in the Trail can be linked together if desired. The Select from the 'Unit ID:' list to change colours for all enabled Responder (R0) and Transponders (T1..T15).
Ship Marker	This is the Marker and its trail that is laid to indicate the current Ship/Transducer position (Marker) and its past whereabouts (Trail). The Colour, Shape and Size of this Marker can be changed and also all points in the Trail can be linked together if desired.
Inverse Cursor Navigation	This will invert the Left/Right and Up/Down operation of the Chart Cursor buttons.
Scale Position	This is the Position on the Chart that the Chart Scale is displayed.
Max Navigation Points	This is the Maximum number of points that any Trail will include.
PPI	The colour of the PPI Rings and Range text on the PPI overlay can be set.
Sonar Range Ring	If the sonar is geo-referenced (configured during installation) then the range rings can be drawn on the chart to illustrate the area of sonar coverage.
Chart	The colour of the Chart Background and Grid Lines can be altered (Note: the chart background is overlaid when a bitmap chart is loaded).
Vehicle Data Display	This will control if the data from the vehicle is displayed on the chart or not (see Section 3.2, "Installation" for more details).

Sub Trail / Ship Trail

These options will configure whether a trail will be shown for the Sub (e.g. Responder/Transponder) and Ship (e.g. USBL Transducer) position updates plotted on the Chart.

There are also options for Pause the update of the Trail, which may be useful during transit or a pause in work and option to Clear the entire Trail, which may be useful to resetting at the start of work.

Saving Sub Trail/Ship Trail to .trl File

The sub and ship trails can be saved to a comma separated ASCII file, with the .trl extension. To import into GIS or other applications, this extension can be renamed as .csv or any other compatible extension type.



Note

The following procedure demonstrates the process for saving a Sub trail. The same process applies for the Ship trail by instead selecting Ship Trail – Save Ship Trail in the pop-up menu of Step 1 shown below.

Procedure

1. In the MicronNav application, right-click on the chart window and select Sub Trail – Save Sub Trail.

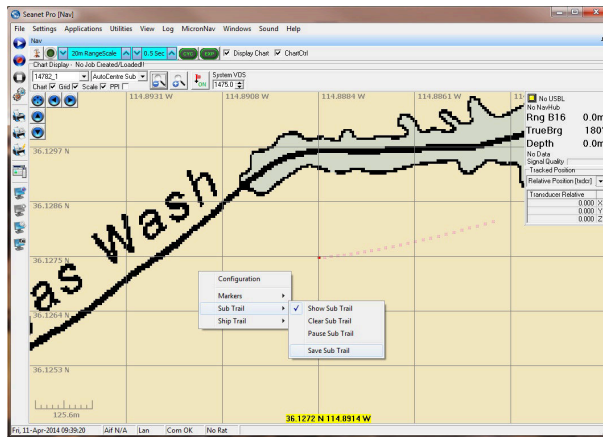

2. Next, in the Save As dialog, enter a name for the output file and click Save.

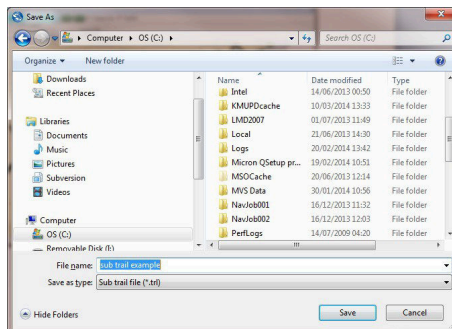

3. Each line of the saved output .trl file will contain the position of a single point in the sub trail. The format of each line of data in the saved output .trl file is: *Lat, Lon, Depth*
4. For the sub trail shown in the example above, the .trl file contents are as follows:

```
36.1282025008669,-114.884130666328,0
36.1281583342003,-114.884322332995,0
36.1281151675336,-114.884513999662,0
36.1280726675336,-114.884705666329,0
36.1280311675336,-114.884896999662,0
36.127990500867,-114.885087999662,0
36.127951000867,-114.885278499662,0
36.1279126675336,-114.885467999663,0
36.1278753342003,-114.885656832996,0
36.1278391675336,-114.885844332996,0
36.127804500867,-114.886030499663,0
36.127771000867,-114.886215332997,0
36.1277388342003,-114.886398332997,0
36.1277081675336,-114.886579499664,0
36.127679000867,-114.886758832997,0
36.1276513342003,-114.886935832998,0
36.1276253342003,-114.887110332998,0
36.127601000867,-114.887282499665,0
36.127578500867,-114.887451666331,0
36.1275576675337,-114.887618166332,0
36.1275386675337,-114.887781332998,0
36.1275216675337,-114.887941332999,0
36.127506500867,-114.888097999665,0
36.127493500867,-114.888250832999,0
36.127482500867,-114.888399999666,0
```

On Chart Measurements

A Left click and drag operation anywhere on the chart will bring up an “elastic band” measuring line which can be used to display Distance and Bearing between two reference points.



6.7. Load BSB Charts

Seanet Pro V2.21 (build 494) onwards has the capability to import BSB charts for use with the MicronNav chart application. It will open any compatible Version 3 BSB chart with the .KAP file extension.

Procedure

1. In the Seanet Pro Menu bar click on `Micron Nav - Charts - Add Chart` (for multi-device applications, if MicronNav is not in the menu make sure that the MicronNav window has been selected first).

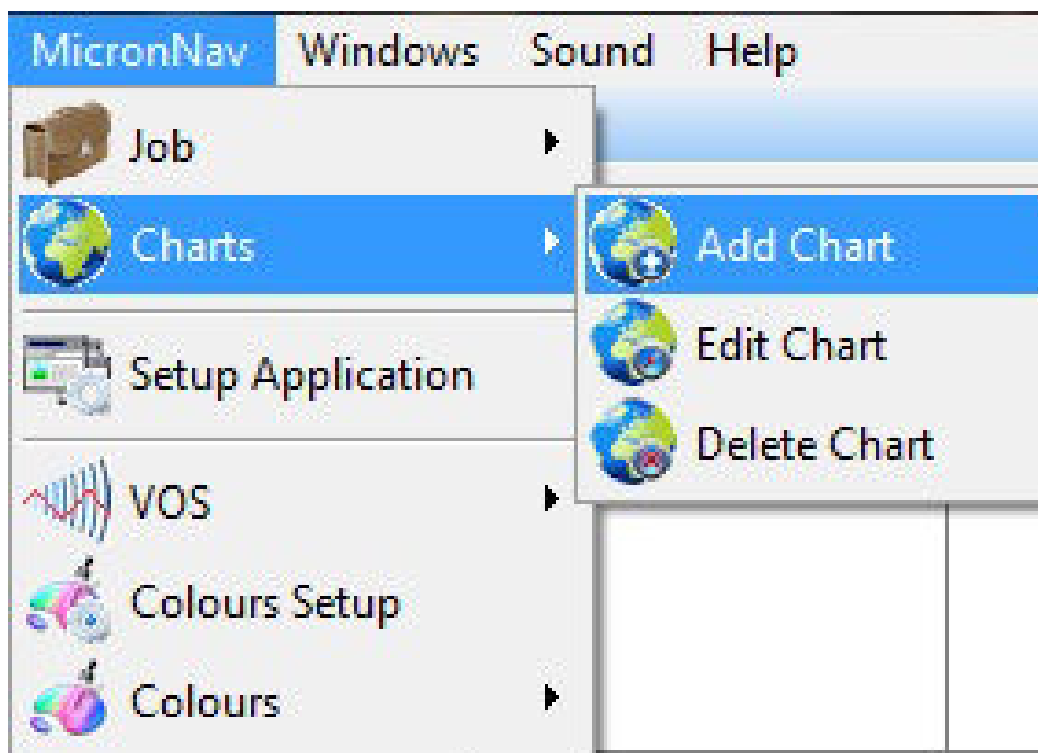

2. In the `Create Overlay Chart` page click on `Load BSB Chart`

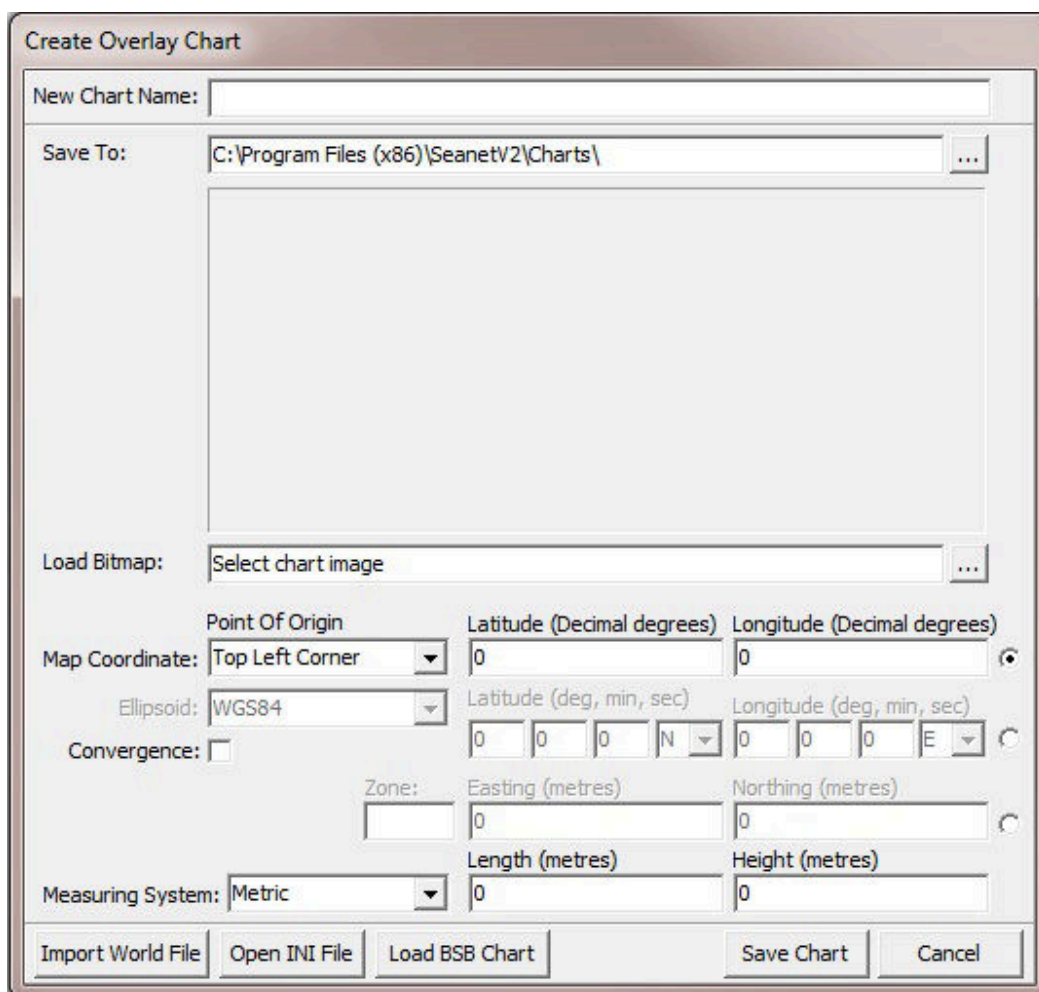

3. The select the required .KAP file from the Load dialog

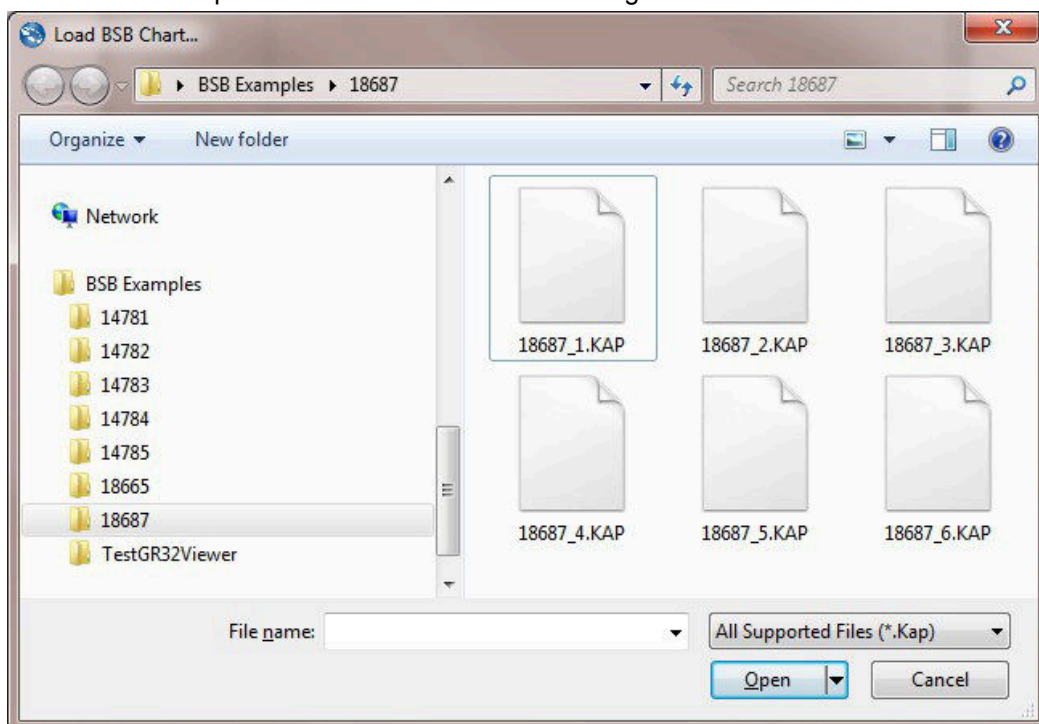

- This will populate the page with the cartographic information extracted from the .KAP file and also display a preview of the chart image.

Create Overlay Chart

New Chart Name: 18687_6

Save To: C:\Program Files (x86)\SeanetV2\Charts\

Load Bitmap: C:\Users\kevin-matson\Desktop\BSB Examples\18687\18687_6.tif

Map Coordinate: Top Left Corner

Point Of Origin: Latitude (Decimal degrees) 36.25343924 Longitude (Decimal degrees) -114.09950229

Ellipsoid: WGS84

Convergence:

Skew Angle: 0°

Zone: Easting (metres) 760609.71 Northing (metres) 4015961.97

Measuring System: Metric

Length (metres) 17702.4 Height (metres) 18235.2

Buttons: Import World File, Open INI File, Load BSB Chart, Save Chart, Cancel



Note

If the image file is very large (e.g, larger than 4000x4000 pixels) then the preview will not be supported. In the cases of extremely large files, depending on the resources of the computer a Cannot allocate DIB handle warning may be displayed during opening or saving the chart. In this event, it may be necessary to re-start Seanet Pro to clear any memory buffers that caused the warning. The chart should then be displayed in the MicronNav chart window on re-opening Seanet Pro.

- Once the page is populated from the cartographic information it is possible to make edits to the chart configuration at this point or at a later stage by selecting `MicronNav - Charts - Edit Chart` from the Seanet Pro menu bar.

The chart normally contains a Latitude/Longitude reference which is not at Top-Left. Seanet Pro will translate this position to a Top-Left reference for its own requirements. This reference position can be further edited if required.

The chart image will be extracted and saved as a .TIF image and by default will be stored in the folder: C:/Program Files (x86)/Seanetv2/Charts/

Convergence will apply an Eccentric grid correction according to Zone (normally required for many BSB charts)

Skew Angle will apply a skew angle to the chart. This value is loaded from the chart but is editable to apply any further corrections.

- Once the chart has been loaded and any necessary edits made, click on **Save Chart** to close the dialog and return to the main screen. The chart will be selected and displayed.

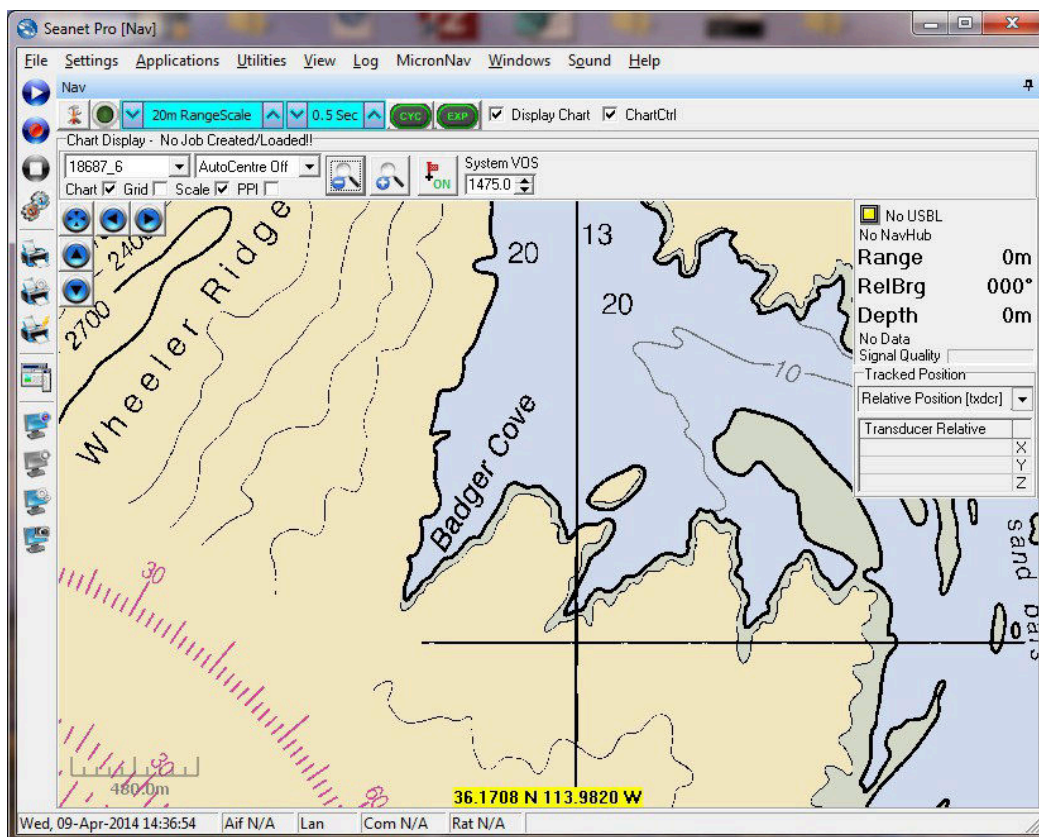

7. Using the External Computer Data Link

The MicronNav data can be made available for use by third party software packages running on an external PC and this section gives details on how to set this up. The external computer data link should be connected as detailed in Section 3.1, "Preparation"

The following list of output strings are currently available:

- Trittech proprietary strings:
 - 'Raw XYZ'
 - 'Proc XYZ'
- Third party strings:
 - 'TP-2EC' (Trackpoint)
 - 'HPR 300P'
 - 'HPR 410' (Simrad HPR)
 - NMEA '\$GPGGA' (Lat/Lon Fix Data)
 - NMEA '\$GPGLL' (Lat/Lon Position)
 - NMEA '\$GPRMC' (Lat/Lon Fix Data)
 - NMEA '\$RATTM' (Tracked Target Message for charting packages)
 - '\$PSIMSSB' (Simrad)
 - '\$GPDBT' (Depth Below Transducer = USBL 'Z' co-ordinate)

Support for *Trittech International Ltd* proprietary strings `Short` and `Long` is planned for future releases.



Note

Other third party industry standard strings may be added at customer request.

7.1. Setting the RemV4 string output

To select the output string format in RemV4:



Note

Up to 4 Output strings can be selected which can be output on the same COM port or a different one.

1. Ensure 'Seanet Pro' is opened and has an Application containing 'Nav' in the name running. This will ensure the Slot list ('Applications' – 'Remote SKV4') of RemV4 is built with the Nav slot (=8) listed.
2. Click on the 'Configure' drop-down button for the Nav item (Slot 8) and select 'Output 1' as shown below.

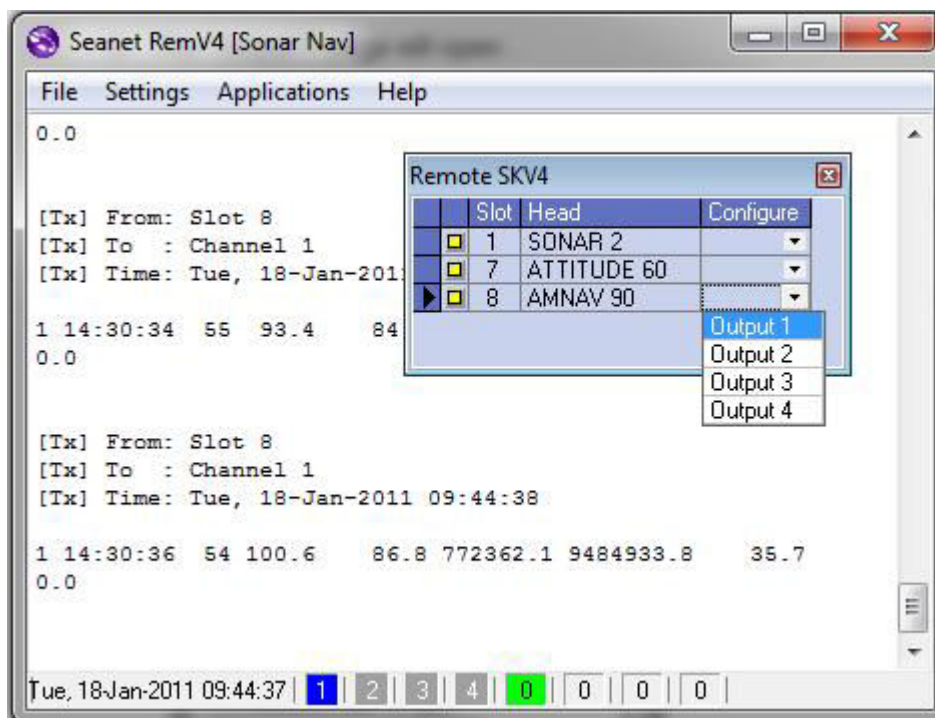

3. The 'Output 1' page will open:

- Set the Channel (Chan 1.. Chan 4) for the output string. Note: A COM port will later be configured for this Channel.
- Set the 'Output Format' of string that is required (the drop-down list showing the 11 available strings is shown below).

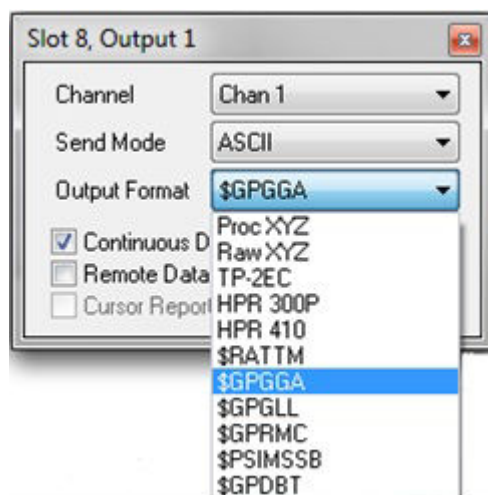

- Some Output Formats have different 'Send Mode' options (e.g. ASCII, Binary, Hex, CSV) which may also need to be configured.
- Ensure 'Continuous Data Output' is enabled.
- An 'ID:' drop-down list will appear when 'GPGGA', 'GPGLL' or 'GPRMC' Output Format is selected. These string formats do not have an ID field and so they must be used with only 1 beacon. Therefore a beacon ID must be selected from the 'ID:' drop-down list for each format ('R0' = Responder, 'T1'..'T15' = Transponders, 'INS' = Micron INS, 'Auto' = will auto-set to first ID detected).

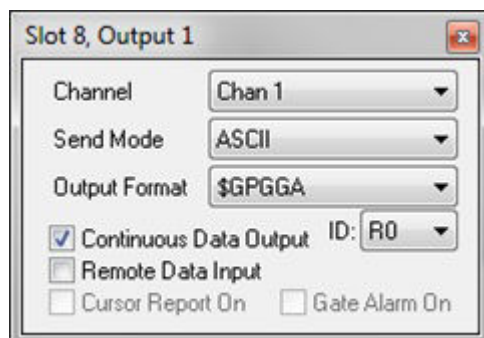

- A 'Force Relative' check-box will appear when 'Proc XYZ', 'TP-2EC', 'HPR 300P' or 'PSIMSSB' Output Format is selected. Ticking the box will force the X, Y output values in the string to be Relative. If unticked then the X, Y output format will auto toggle between Relative and (if world position co-ordinates are available) World position formats. Immediately underneath the 'Force Relative' check-box is a drop-down list where the Relative X,Y,Z output can be selected to be taken from the Dunking Transducer ('Txdcr') or Ship datum.

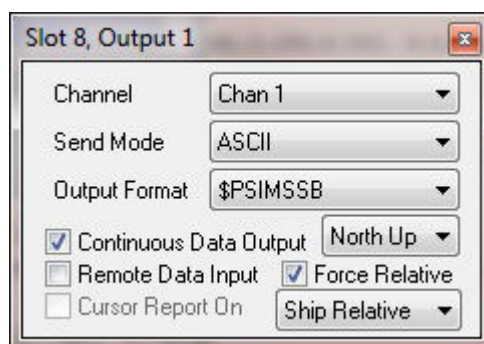

Note

The drop-down list will also appear for the 'HPR410' and '\$RATTM' strings which only have a Relative output format option. 'Ship Relative' / 'Txdcr Relative' sets the origin for the Relative Output. 'North Up' / 'Hdg Up' will also change the reference frame for the Relative Output in applicable strings.

4. Close the 'Output 1' page with the 'X' button on the top-right of the page. Open the 'Remote Channel Setup' page ('Settings' – 'Channels') and configure the Channel that was selected in the step above.

Channel	COM Port	Enabled	Baud Rate	Settings	Status	Type
Chan 1	1	<input checked="" type="checkbox"/>	19200	...	OK	Generic
Chan 2	2	<input type="checkbox"/>	19200	...	Not Available	N/A
Chan 3	3	<input type="checkbox"/>	19200	...	Not Available	N/A
Chan 4	4	<input type="checkbox"/>	19200	...	Not Available	N/A

5. To use a Com port from the MicronNav Hub to output the REMV4 data proceed as follows. (The example below shows the MicronNav Hub Port A being configured for REMV4)
6. "Spin" the COM Port up or down until the Type displays SEAHUB A. Set the baud rate to match the connecting computer.

7. This port must then be configured to RS232. To do this you must open the Seantet Setup program, detect Node 90 and Click on ACTION Setup as indicated below.

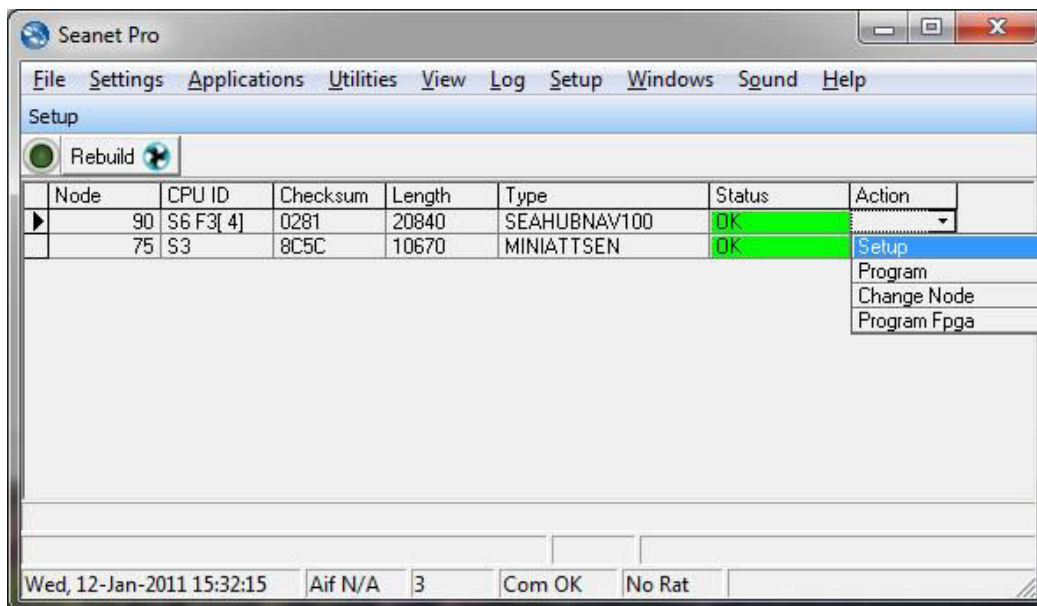

8. Configure "Port A Mode" to RS232 using the drop down and press OK to program this setting into the SeaNav Hub

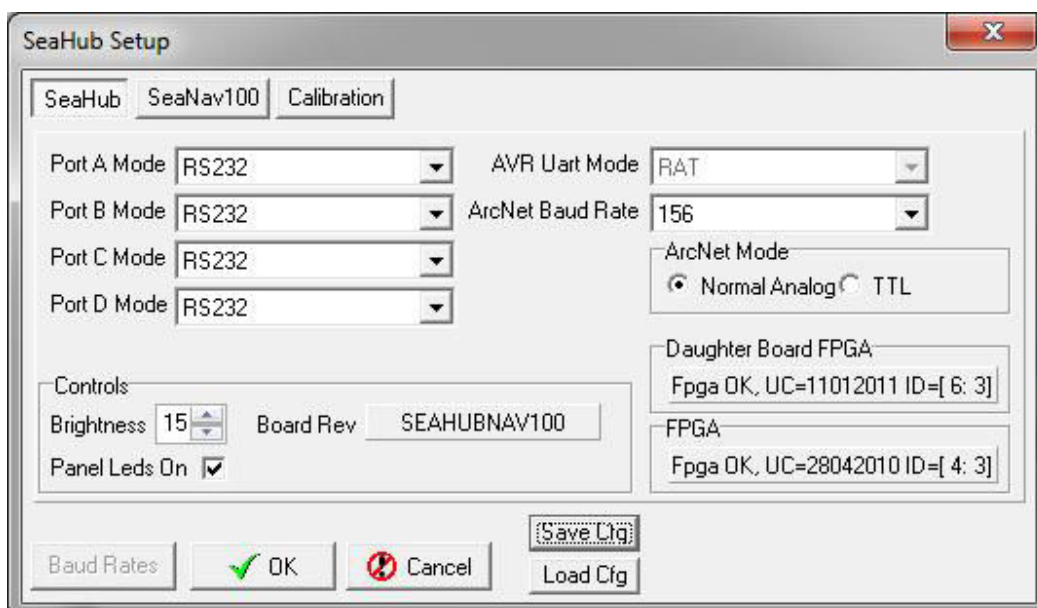

7.2. List of Current String Formats

7.2.1. Proc XYZ

The 'Proc XYZ' data message contains the World X,Y & Z co-ordinate position of the Responder/Transponder. The output message will include a message header and be in the following format, in accordance with the proprietary RemV4 output protocol.

```
"%D" + SlotReplyHdr + 'Proc XYZ' Nav Data Structure + <CR><LF>
```

SlotReplyHdr Data Structure (sent in hexadecimal format)		
Data Description	Data Range	Data Types
Total Number of Bytes in Message in Hex (including Command and Reply codes)	NB	CARDINAL
Slot Number (range "01" to "0C")	SlotN	SLOTN
Generic Device Type	SourceTypes	SOURCEN
Data Reply Mode (0=ASCIIText, 1=Hex, 2=Binary, 3=CSV)	0,1,2 or 3	DIGIT
Send SeaKing Long = 3*, Send SeaKing Short = 2*, Send Raw data = 1, Send Processed Data = 0 (*Not applicable)	0,1,2 or 3	DIGIT
<p><i>Example:</i> Byte Count = Hex 0049 (73) Slot = 08 = MicronNav Sourcetype = 32(Hex 20) = Null (not defined for MicronNav) Data reply mode is ASCIIText Send data = 0 = Proc XYZ ALWAYS Hex e.g., "0049082000"</p>		

'Proc XYZ' Nav Data Structure		
Data Description	Data Range	Data Types
Unit ID (0 = Responder, 1..15 = Transponder, 19=INS)	0 to 19	SHORTCARD
World X co-ordinate (Easting), including datum position offset.	-9.99999E-37 to +9.99999E+37	REAL
World Y co-ordinate (Northing), including datum position offset.	-9.99999E-37 to +9.99999E+37	REAL
Vertical position relative to vessel transducer and including datum position offset (in millimetres, +ve is downwards)	000000000 to 100000000	LONGINT
Quality Flag / RMS Error. Larger values indicate better quality.	0.0 to 3.0	REAL
Valid Reply Set Bit 0 = 1 = Tx Transducer Ok Bit 1 = 1 = Rx 1 Transducer Reply Ok Bit 2 = 1 = Rx 2 Transducer Reply Ok Bit 3 = 1 = Rx 3 Transducer Reply Ok Bit 4 = 1 = Rx 4 Transducer Reply Ok e.g., Valid reply = Bits 1 to 4 set to 1 = "30" (or "31")	000 to 031	SHORTCARD
Time of data, local time = hhmmssdd	00000000 to 23595999	hhmmssdd
<p><i>Example:</i> Unit ID = 0 (Responder), World X co-ordinate (Easting) of 503868.427, World Y co-ordinate (Northing) of 6025011.669, Vertical Z co-ordinate of 4.102m, Quality Flag = 0.8, Valid reply Set = 30 (all valid), Fix taken at 15:31:56.</p> <p>ASCII Text = "%D004B082000000+5.03868427E+05+6.02501167E+06+ 0000004102+0.80000E+0003015315632<CR><LF>"</p> <p>CSV = "%D003E082030,0,503868.427,6025011.669,+4102,0.8,30,15315632<CR><LF>"</p>		

7.2.2. Raw XYZ

The 'Raw XYZ' data message contains the Relative X,Y & Z co-ordinate position of the Responder/Transponder. The output message will include a message header and be in the following format, in accordance with the proprietary RemV4 output protocol...

```
"%D" + SlotReplyHdr + `Raw XYZ' Nav Data Structure + <CR><LF>
```

SlotReplyHdr Data Structure (this Data Structure is sent in Hex Format)		
Data Description	DataCodes/Range	Data Types
Total Number of Bytes in Message in Hex (including Command and Reply codes)	NB	CARDINAL
Slot Number (range "01" to "0C")	SlotN	SLOTN
Generic Device Type	SourceTypes	SOURCEN
Data Reply Mode (0=ASCIIText, 1=Hex, 2=Binary, 3=CSV) *CSV = Comma Separated ASCII	0 or 1 or 2 or 3	DIGIT
Send SeaKing Long = 3*, Send SeaKing Short = 2*, Send Raw data = 1, Send Processed Data = 0 *Not applicable	0 or 1 or 2 or 3	DIGIT
<i>Example:</i> Byte Count = Hex 0049 (73) Slot = 08 = MicronNav Sourcetype = 32(Hex 20) = Null (not defined for MicronNav) Data reply mode is ASCIIText Send data = 1 = Raw XYZ ALWAYS Hex e.g. "0049082001"		

'Raw XYZ' Nav Data Structure		
Data Description	DataRange	Data Types
Unit ID (0 = Responder, 1..15 = Transponder, 19=INS)	0 to 19	SHORTCARD
Relative X co-ordinate. Horizontal distance athwart from reference position (in millimetres, +ve = towards starboard)	0000000000 to 1000000000	LONGINT
Relative Y co-ordinate. Horizontal distance fore/aft from reference position (in millimetres, +ve = forwards)	0000000000 to 1000000000	LONGINT
Relative Z co-ordinate. Vertical distance from reference position (in millimetres, +ve is downwards)	0000000000 to 1000000000	LONGINT
Quality Flag / RMS Error. Larger values indicate better quality.	0.0 to 3.0	REAL
Valid Reply Set Bit 0 = 1 = Tx Transducer Ok Bit 1 = 1 = Rx 1 Transducer Reply Ok Bit 2 = 1 = Rx 2 Transducer Reply Ok Bit 3 = 1 = Rx 3 Transducer Reply Ok Bit 4 = 1 = Rx 4 Transducer Reply Ok E.G. Valid reply = Bits 1 to 4 set to 1 = "30" (or "31")	000 to 031	SHORTCARD
Time of data, local time = hhmmssdd	00000000 to 23595999	hhmmssdd
<p><i>Example:</i> Unit ID = 0 (Responder), Relative X co-ord of -18.686m, Relative Y co-ord of 4.764m, Relative Z co-ord of 4.1m, Quality Flag = 0.8, Valid reply Set = 30 (all valid), Fix taken at 15:31:56.</p> <p>ASCII Text = "%D0049082001000-0000018686+0000004764+0000004100+0.80000E+0003015315632<CR><LF>"</p> <p>CSV = "%D0033082031,0,-18686,+4764,+4100,0.8,30,15315632<CR><LF>"</p>		

7.2.3. TP-2EC

This 3rd party output string is taken from the Trackpoint positioning system. The string has 68 characters and the format is ASCII fixed field with space separators. Leading 0's (except time) are space filled. X,Y,Z co-ordinate positions are relative values unless GPS is active in which case the co-ordinate outputs become Easting, Northing and Depth respectively.

The full string format is as follows:

'TP-2EC' Reply Data Structure		
Data Description	Data Range	Field Range
Unit ID, in Hex (0 = Responder, 1..F = Transponder, 13=INS)	0 to Fh (0 to 19)	i
Fix Time (Local Time)	00:00:00 to 23:59:59	hh:mm:ss
Compass Heading (degrees)	0 to 359	ccc
Position Bearing (degrees)	0 to 359.9	bbb.b
Position Slant Range (metres)	0 to 99999.9	rrrrr.r
X (or Easting)	0 to 999999.9	xxxxxx.x
Y (or Northing)	0 to 999999.9	yyyyyy.y
Z (or Depth)	0 to 99999.9	zzzzz.z
Telemetry	Always 0.0	t.t
Error	' '(No Error) or ' 6' (Lost Signal)	ee
(Carriage Return + Line Feed)	N/A	<CR><LF>
<p><i>Example:</i> GPS is active so co-ordinates are World. Unit ID = 0 (Responder), Fix taken at 15:33:02, Compass Heading = 337°, Position Bearing = 277.6°, Position Slant Range = 20.8m, X Co-ord (East) of 503871.9, Y Co-ord (North) of 602501.0, Z Co-ord (Depth) of 13.0m, No Error.</p> <p>ASCII Output Always (on a single line) = "0*15:33:02*337*277.6****20.8*503871.9* 602501.0****13.0*****0.0***<CR><LF>"</p> <p>Where; "*" is a space (ASCII code 32), "<CR>" is Carriage Return (ASCII code 13), "<LF>" is Line Feed (ASCII code 10).</p>		

7.2.4. Simrad HPR 300P

This 3rd party output string is taken from the Simrad HPR positioning system. The string has 48 characters and the format is ASCII fixed field with space separators. Leading 0's (except time) are space filled. X,Y,Z co-ordinate positions are relative values unless GPS is active in which case the co-ordinate outputs become Easting, Northing and Depth respectively. For values greater than 999.9, the decimal point is removed (e.g. 1001.1 is output as "1001").

The full string format is as follows:

'HPR 300P' Reply Data Structure		
Data Description	Data Range	Field Range
Beacon / Unit ID (0 = Responder, 1..15 = Transponder, 19=INS)	0 to 19	ii
Transducer Number	Always 1	H
Beam	Always 'W'	B
Status	'OK' (No error) or 'NRY' (No reply)	SSS
Compass heading (degrees)	0 to 359.9	ccc.c
X (or Easting)	0 to 999999	xxxx.x (or xxxxxx)
Y (or Northing)	0 to 999999	yyyy.y (or yyyyyy)
Z (or Depth)	0 to 999999	zzzz.z (or zzzzzz)
Quality Flag, unused	Always 0.0	QQ.Q
(Carriage Return + Line Feed)	N/A	<CR><LF>
<p><i>Example:</i> GPS is active so co-ordinates are World. Unit ID = 0 (Responder), Compass Heading = 119.5°, X Co-ord (East) of 339080, Y Co-ord (North) of 497512, Z Co-ord (Depth) of 13.7m, No Error.</p> <p>ASCII Output Always = "0**1**W***OK**119.5*339080*497512***13.7***0.0<CR><LF>"</p> <p>Where; "*" is a space (ASCII code 32), "<CR>" is Carriage Return (ASCII code 13), "<LF>" is Line Feed (ASCII code 10).</p>		

7.2.5. Simrad HPR 410

This 3rd party output string is taken from the Simrad HPR positioning system. The binary output telegram is 70 bytes long. The binary telegram includes a Telegram Header and Tail in line with the Simrad HPR protocol. The contained Message Type is 'Message 1, Transponder Position Data' (Data Block of 62 bytes).

The full binary telegram format is as follows:

'HPR 410' Reply Data Structure		
Data Description	Data Range	Field Range
Header		
Start Character	Always 55h	ShortCard
Block Length	1 to 65536	Cardinal
Message Type	Always 1	ShortCard
Destination	Always 0	ShortCard
Message Block (62 bytes)		
Tp Index / ID (0 = Responder, 1..15 = Transponder, 19=INS)	0 to 19	Cardinal
Operation Mode	Always 0	ShortCard
Sync Mode	Always 0	ShortCard
Tp Mode/Type	0 = Transponder, 10 = Responder	ShortCard
Tp Operation	Always 1 (Mobile Tp)	ShortCard
Pos Data Form	Bit 0 (0 = vessel, 1 = north)	ShortCard
Reply Status	Fixed at 0 (= Okay)	ShortCard
Filt x pos - Filtered Horiz Distance athwart from reference pos (in metres)	-9.99999E-37 to +9.99999E+37	Real
Filt y pos - Filtered Horiz Distance fore/aft from reference pos (in metres)	-9.99999E-37 to +9.99999E+37	Real
Filt z pos - Filtered Vert Distance from reference pos (in metres)	-9.99999E-37 to +9.99999E+37	Real
X pos - Raw Horiz Distance athwart from reference pos (in metres)	-9.99999E-37 to +9.99999E+37	Real
Y pos - Raw Horiz Distance fore/aft from reference pos (in metres)	-9.99999E-37 to +9.99999E+37	Real
Z pos - Raw Vert Distance from reference pos (in metres)	-9.99999E-37 to +9.99999E+37	Real
Slant Range - Raw Slant Range from transducer to Transponder (in metres)	-9.99999E-37 to +9.99999E+37	Real
P course - Vessel heading Course (in degrees)	-9.99999E-37 to +9.99999E+37	Real
P roll - Vessel Roll (+/-180 degs)	-9.99999E-37 to +9.99999E+37	Real
P pitch - Vessel Pitch (+/-180 degs)	-9.99999E-37 to +9.99999E+37	Real
Td beam	0 = wide, 1 = narrow	ShortCard
Td type	Not used, Always 0	ShortCard
Td num	Always 1	Cardinal
Diagnostic	Not used, Always 0	Cardinal
Standard deviation, unused	Always 0.0	Real

'HPR 410' Reply Data Structure		
Data Description	Data Range	Field Range
Inst Data	Not used, Always 0	Real
Footer Tail		
Checksum(Sum of all bytes excluding Checksum and Stop Character)	1 to 65536	Cardinal
Stop Character	Always AAh	ShortCard
<i>Example:</i> The output telegram is binary so a viewable example is not given.		

7.2.6. NMEA \$RATTM

This NMEA 'Tracked Target Message' is a commonly used string in charting/navigation packages. The comma-separated ASCII string contains the target Range & Bearing and UTC Time-stamp. Target speed and course are not calculated and so are not contained in the string. Any fields with no calculated data will be padded with zero value data.

The full string format is as follows:

'\$RATTM' Reply Data Structure		
Data Description	Data Range	Field Range
NMEA string header	Always '\$RATTM'	hhhhhh
Comma separator	Always ','	,
Target number	00 to 99	ii
Comma separator	Always ','	,
Horizontal Target Distance from vessel (in nautical miles)	0 to 9.9999	d.dddd
Comma separator	Always ','	,
Target Bearing (degrees)	0 to 359.9	bbb.b
Comma separator	Always ','	,
Bearing Degrees identifier	'R' or 'T'	'R' (Relative) or 'T' (True)
Comma separator	Always ','	,
Target Speed, not calculated so padded with zero	Always '0.0'	s.s
Comma separator	Always ','	,
Target Course, not calculated so padded with zero	Always '0.0'	c.c
Comma separator	Always ','	,
Degrees identifier, unused so defaulted to 'T'	'R' or 'T'	'R' (Relative) or 'T' (True)
Comma separator	Always ','	,
Distance of closest point of approach, not calculated so padded with zero	Always '0.0'	p.p
Comma separator	Always ','	,
Time to CPA, min, ("-" increasing), not calculated so padded with zero	Always '0.0'	t.t
Comma separator	Always ','	,
Speed/Distance units	Always 'N' (nautical miles)	K/N/S (km/ nautical miles/ statue miles)
Comma separator	Always ','	,
Target name (0 = Responder, 1..15 = Transponder)	e.g. "TARGET0" to "TARGET1"	ASCII variable field
Comma separator	Always ','	,
Target Status	'L' or 'T'	L = Lost, Q = Query in process, T = Tracking
Comma separator	Always ','	,
Target ?	Always null	R = Reference Target, otherwise null

'\$RATTM' Reply Data Structure		
Data Description	Data Range	Field Range
Comma separator	Always ','	,
Time of data, UTC = hhmmss.ss	000000.00 to 235959.99	hhmmss.ss
Comma separator	Always ','	,
Type of acquisition	Always 'A'	A = Auto, M = Manual, R = Reported
Delimiter (asterisk)	Always '*'	*
Checksum (in Hexadecimal) (XOR of bytes between, but not inclusive of, '\$' and '*')	00 to FF	cc
(Carriage Return + Line Feed)	N/A	<CR><LF>
<p><i>Example:</i> Target Number / Unit ID = 0 (Responder), Horizontal Target Range = 2 metres = 0.0011 nautical miles, Relative Target Bearing = 326.0°, UTC Time of reading = 005940.13.</p> <p>ASCII Output Always (on a single line) = "\$RATTM,00,0.0011,326.0,R,0.0,0.0,R,0.0,0.0,N, TARGET1,T,,005940.13,A*5B<CR><LF>"</p> <p>Where; "<CR>" is Carriage Return (ASCII code 13), "<LF>" is Line Feed (ASCII code 10).</p>		

7.2.7. NMEA \$GPGGA

This NMEA string format is used for Global Positioning and mainly sent by GPS devices. It is a common format for providing co-ordinate positions in Latitude / Longitude format. There are a number of fields in this string that are not applicable and these fields have been set to sensible values as default.

The full string format is as follows:

'\$GPGGA' Reply Data Structure		
Data Description	Data Range	Field Range
NMEA string header	Always '\$GPGGA'	hhhhhh
Comma separator	Always ','	,
Time of data, UTC = hhmmss.ss	000000.00 to 235959.99	hhmmss.ss
Comma separator	Always ','	,
Latitude of Target in Deg Min (Only valid when Compass and GPS input data are valid)	0 to 90 Degs	DDMM.SSSS
Comma separator	Always ','	,
Latitude N or S	'N' or 'S'	a
Comma separator	Always ','	,
Longitude of Target in Deg Min (Only valid when Compass and GPS input data are valid)	0 to 180 Degs	DDDMM.SSSS
Comma separator	Always ','	,
Longitude E or W	'E' or 'W'	a
Comma separator	Always ','	,
GPS Quality Indicator	Always 2 (DGPS)	x
Comma separator	Always ','	,
Number of Satellites in Use	Always 7 (N/A)	xx
Comma separator	Always ','	,
HDOP	Always 2.2	x.x
Comma separator	Always ','	,
Antenna Altitude	Always 0.0	x.x
Comma separator	Always ','	,
Altitude Units Identifier	'M' for metres	a
Comma separator	Always ','	,
Geoidal Separation	Always 0.0	x.x
Comma separator	Always ','	,
Units Identifier	'M' for metres	a
Comma separator	Always ','	,
Age of Differential GPS data	Always 1.2	x.x
Comma separator	Always ','	,
Differential Reference Station ID	Always 1234	xxxx
Comma separator	Always ','	,
Delimiter (asterisk)	Always '**'	*

'\$GPGGA' Reply Data Structure		
Data Description	Data Range	Field Range
Checksum (in Hexadecimal) (XOR of bytes between, but not inclusive of, '\$' and '*')	00 to FF	cc
(Carriage Return + Line Feed)	N/A	<CR><LF>
<p><i>Example:</i> UTC Time of reading = 144014.71, Target Latitude = 54° 22' 21.74" (N), Target Longitude = 2° 56' 25.07" (W).</p> <p>ASCII Output Always (on a single line) = "\$GPGGA,144014.71,5422.3624,N,00256.4178,W,2,07,2.2,0.0, M,0.0,M,1.2,1234*5C<CR><LF>"</p> <p>Where; "<CR>" is Carriage Return (ASCII code 13), "<LF>" is Line Feed (ASCII code 10).</p>		

7.2.8. NMEA \$GPGLL

This NMEA string format is used for Global Positioning and mainly sent by GPS devices. It is a common format for providing co-ordinate positions in Latitude / Longitude format.

The full string format is as follows:

'\$GPGLL' Reply Data Structure		
Data Description	Data Range	Field Range
NMEA string header	Always '\$GPGLL'	hhhhhh
Comma separator	Always ','	,
Latitude of Target in Deg Min (Only valid when Compass and GPS input data are valid)	0 to 90 Degr	DDMM.SSSS
Comma separator	Always ','	,
Latitude N or S	'N' or 'S'	a
Comma separator	Always ','	,
Longitude of Target in Deg Min (Only valid when Compass and GPS input data are valid)	0 to 180 Degr	DDDMM.SSSS
Comma separator	Always ','	,
Longitude E or W	'E' or 'W'	a
Comma separator	Always ','	,
Time of data, UTC = hhmmss.ss	000000.00 to 235959.99	hhmmss.ss
Comma separator	Always ','	,
Fix Status (invalid if Ping not okay or no valid attitude or compass data)	'A' = Valid, 'V' = Invalid	x
Delimiter (asterisk)	Always '*'	*
Checksum (in Hexadecimal) (XOR of bytes between, but not inclusive of, '\$' and '*')	00 to FF	cc
(Carriage Return + Line Feed)	N/A	<CR><LF>
<p><i>Example:</i> Target Latitude = 54° 22' 22.21" (N), Target Longitude = 2° 56' 23.91" (W), UTC Time of reading = 143231.51. ASCII Output Always = "\$GPGLL,5422.3701,N,00256.3986,W,143231.51,A*54<CR><LF>" Where; "<CR>" is Carriage Return (ASCII code 13), "<LF>" is Line Feed (ASCII code 10).</p>		

7.2.9. NMEA \$GPRMC

This NMEA string format is used for Global Positioning and mainly sent by GPS devices. It is a common format for providing co-ordinate positions in Latitude / Longitude format.

The full string format is as follows:

'\$GPRMC' Reply Data Structure		
Data Description	Data Range	Field Range
NMEA string header	Always '\$GPRMC'	hhhhhh

'\$GPRMC' Reply Data Structure		
Data Description	Data Range	Field Range
Comma separator	Always ','	,
Time of data, UTC = hhmmss.ss	000000.00 to 235959.99	hhmmss.ss
Comma separator	Always ','	,
Fix Status (N.B. Invalid if Ping not okay or no valid attitude or compass data)	'A' = Valid, 'V' = Invalid	x
Comma separator	Always ','	,
Latitude of Target in Deg Min (Only valid when Compass and GPS input data are valid)	0 to 90 Degs	DDMM.SSSS
Comma separator	Always ','	,
Latitude N or S	'N' or 'S'	a
Comma separator	Always ','	,
Longitude of Target in Deg Min (Only valid when Compass and GPS input data are valid)	0 to 180 Degs	DDDMM.SSSS
Comma separator	Always ','	,
Longitude E or W	'E' or 'W'	a
Comma separator	Always ','	,
Speed Over Ground (in knots)	Not calculated, always 0.00	x.xx
Comma separator	Always ','	,
Course Over Ground (in degrees)	Not calculated, always 000.00	xxx.xx
Date of data	Gregorian calendar 010100 to 311299	ddmmyy
Comma separator	Always ','	,
Magnetic Variation	N/A, always ""	x
Comma separator	Always ','	,
Delimiter (asterisk)	Always '*'	*
Checksum (in Hexadecimal) (XOR of bytes between, but not inclusive of, '\$' and '*')	00 to FF	cc
(Carriage Return + Line Feed)	N/A	<CR><LF>
<p><i>Example:</i> Target Latitude = 54° 22' 22.30" (N), Target Longitude = 2° 56' 25.51" (W), UTC Time of reading = 143221.57, Date of reading = 9th May 2008.</p> <p>ASCII Output Always (on a single line) = "\$GPRMC,143221.57,A,5422.3717,N,00256.4252,W,0.00,000.00,090508,,*0F<CR><LF>"</p> <p>Where; "<CR>" is Carriage Return (ASCII code 13), "<LF>" is Line Feed (ASCII code 10).</p>		

7.2.10. \$PSIMSSB

This 3rd party output string is taken from the Simrad HiPAP positioning system. The string is variable length ASCII with comma field separators. X,Y,Z co-ordinate positions are relative values unless GPS is active in which case the co-ordinate outputs become Easting, Northing and Depth respectively.

The full string format is as follows:

'\$PSIMSSB' Reply Data Structure		
Data Description	Data Range	Field Range
NMEA string header	Always '\$PSIMSSB'	hhhhhhh
Comma separator	Always ','	,
Time of data (UTC time)	000000.00 to 235959.99	hhmmss.ss
Comma separator	Always ','	,
Beacon/Target ID (0 = Responder, 1..15 = Transponder, 19=INS)	B00 to B99	ccc
Comma separator	Always ','	,
Target Status	'A' = Okay, 'V' = Not Okay	A
Comma separator	Always ','	,
Error Code, left empty	Always blank	
Comma separator	Always ','	,
Coordinate system	'C' = Relative Cartesian, 'U' = Absolute UTM	A
Comma separator	Always ','	,
Orientation	'H' for Heading up & 'N' for North up (both when output is Relative XY), 'E' for Easting, Northing (when in Absolute UTM format)	A
Comma separator	Always ','	,
SW Filter	'M' for Measured, 'F' for Filtered	A
Comma separator	Always ','	,
X (or Easting)	0 to 999999	x.x
Comma separator	Always ','	,
Y (or Northing)	0 to 999999	y.y
Comma separator	Always ','	,
Z (or Depth)	0 to 999999	z.z
Comma separator	Always ','	,
Expected Accuracy, unused	Always 0.0	q.q
Comma separator	Always ','	,
Additional information	Always 'N'	A
Comma separator	Always ','	,
1st Additional value	Always blank	
Comma separator	Always ','	,
2nd Additional value	Always blank	

'\$PSIMSSB' Reply Data Structure		
Data Description	Data Range	Field Range
Delimiter (asterisk)	Always '*'	*
Checksum (in Hexadecimal) (XOR of bytes between, but not inclusive of, '\$' and '*')	00 to FF	cc
(Carriage Return + Line Feed)	N/A	<CR><LF>
<p><i>Example:</i> GPS is active so co-ordinates are World. Time of reading = 204854.17, Beacon ID = 00 (Responder), X Co-ord (East) of 538087.76, Y Co-ord (North) of 7039253.894, Z Co-ord (Depth) of 56.486m, Status = Okay.</p> <p>ASCII Output Always (on a single line) = "\$PSIMSSB,204854.17,00,A,,C,H,M,538087.760, 7039253.894,56.486,0.0,N,,*26<CR><LF>"</p> <p>Where; "<CR>" is Carriage Return (ASCII code 13), "<LF>" is Line Feed (ASCII code 10).</p>		

7.2.11. NMEA \$GPDBT

This NMEA string format is used for Water Depth data output and is the Depth Below Transducer value that is mainly sent by positioning devices. It provides the Z (Depth) coordinate output position in the USBL system.

The full string format is as follows:

'\$GPDBT' Reply Data Structure		
Data Description	Data Range	Field Range
NMEA string header	Always '\$GPDBT'	hhhhhh
Comma separator	Always ','	,
Depth in units of Feet	0 to 999999	f.ff
Comma separator	Always ','	,
Units Identifier	Always 'f'	U
Comma separator	Always ','	,
Depth in units of Metres	0 to 999999	M.MM
Comma separator	Always ','	,
Units Identifier	Always 'M'	U
Comma separator	Always ','	,
Depth in units of Fathoms	0 to 999999	F.FF
Comma separator	Always ','	,
Units Identifier	Always 'F'	U
Delimiter (asterisk)	Always '*'	*
Checksum (in Hexadecimal) (XOR of bytes between, but not inclusive of, '\$' and '*')	00 to FF	cc
(Carriage Return + Line Feed)	N/A	<CR><LF>
<p><i>Example:</i> Z (Depth) value = 54.12 metres.</p> <p>ASCII Output Always = "\$GPDBT,177.55,f,54.12,M,29.59,F*32<CR><LF>"</p> <p>Where; "<CR>" is Carriage Return (ASCII code 13), "<LF>" is Line Feed (ASCII code 10).</p>		

7.2.12. Notes

RemV4 Data Types			
Data Type	Binary Mode	Hex Mode	ASCII Text Mode
REMCH			“.”
REPCH			“%”
BOOLEAN	Nibble	“b”	“0” or “1”
DIGIT	Nibble	“n”	Any Digit “0” to “9”
CHAR	<byte>	<byte>	Any printable ASCII
SHORTCARD	<byte>	“Nn”	“000” to “255”
SHORTINT	<byte>	“Nn”	“-128” to “+128”
CARDINAL	<LSB><MSB>	“MmLl”	“00000” to “65535”
INTEGER	<LSB><MSB>	“MmLl”	“-32768” to “+32767”
LONGCARD	<LSB><. . .><MSB>	“Mm....Ll”	“0000000000” to “4294967296”
LONGINT	<LSB><. . .><MSB>	“Mm....Ll”	“-2147483648” to “+2147483647”
REAL	<LSB><. . .><MSB>	“Mm....Ll”	“-9.99999E-37” to “+9.99999E+37”
LONGREAL	<LSB>,6*<. . .><MSB>	“Mm.....Ll”	“-9.99999999E-307” to “+9.99999999E+307”
TIME	<C><S><M><H>	“HhMmScCc”	“HHMMSSCC”
DATE	<D><M><Y>	“DdMmYyyy”	“DDMMYYYY”
SLOTN	<1..12>	“Nn” (“01” to “0C”)	“01” to “12”
SOURCEN	<0..99>	“Nn” (“00” to “63”)	“00” to “99”
DEVICEN	<0..99>	“Nn” (“00” to “63”)	“00” to “99”
NODEN	<1..15>	“Nn” (“01” to “63”)	“01” to “99”

8. Using with Other Trittech Sonars

The MicronNav was initially developed for use on small observation type ROVs in conjunction with the MKII/MKIII Micron and SeaSprite DST Sonars and throughout this manual this is the Sonar referred to, it is possible however to operate the MicronNav with other Trittech Sonar in the same way as that detailed for the MKII/MKIII Micron and SeaSprite DST. The following list provides details on MicronNav compatibility with the other Trittech Sonars.

Micron Sonar:

Analogue Micron Sonar	NOT SUPPORTED
Micron DST Sonar MKI	REQUIRES NULL MODEM INTERCONNECT CABLE
Micron DST Sonar MKIII	FULLY SUPPORTED (SAME AS MKII)

SeaSprite Sonar:

Analogue SeaSprite Sonar	NOT SUPPORTED
SeaSprite DST Sonar MKI	REQUIRES NULL MODEM INTERCONNECT CABLE
SeaSprite DST Sonar MKIII	FULLY SUPPORTED (SAME AS MKII)

SeaPrince Sonar:

SeaPrince Sonar	NOT SUPPORTED
Super SeaPrince DST Sonar	REQUIRES STANDARD TRITECH CONNECTOR TO MICRON CONNECTOR INTERCONNECT CABLE

MiniKing Sonar:

MiniKing Sonar	NOT SUPPORTED
----------------	---------------

SeaKing Sonar:

SeaKing Sonar	NOT SUPPORTED
SeaKing DST Sonar	REQUIRES STANDARD TRITECH CONNECTOR TO MICRON CONNECTOR INTERCONNECT CABLE

Gemini:

Gemini 720i / 720id	REQUIRES SPECIALISED INTERCONNECT CABLE ¹
Gemini 720is	SERIAL AUX PORT REQUIRED AND SPECIALISED INTERCONNECT CABLE ²

Notes:

- ¹ - Please contact *Trittech International Ltd* for more information
- ² - Please contact *Trittech International Ltd* for more information

9. Adding a Micron Echosounder

When operating the MicronNav System in Responder mode in conjunction with a *Tritech International Ltd* Sonar, a Micron Echosounder can be added to the subsea installation. The Micron Echosounder is a sonar ranging device which mounted vertically gives altitude above the seabed or in any other attitude provides a subsea distance measurement (see Micron Echosounder Product Manual for further details).



Connect the Micron Echosounder (“Main” port) to the MicronNav subsea Modem head (“Aux” port) using a Double Ended Micron Interconnect cable available from Tritech.

The Micron Echosounder requires a voltage of +9 to +50V DC and will draw approximately 1.72W when running (typical current will be 225mA @9v or 72mA @ 24V), as the Micron Echosounder takes its power from the MicronNav subsea Modem head which is ‘daisy chained’ with the Tritech Sonar head consideration must be given to the overall power requirement.

The Micron Echosounder (“Main” port) communications should be configured to RS232 at a baud rate of 9600Bd to match that of the Modem head (“Aux” port). The Micron Echosounder Main port is factory configured at time of supply, if this needs to be changed then contact Tritech for details.

Installation Notes:

- The connector sockets are not usable “open face” and should always be sealed with the blanking-plug provided if not being used.
- Care should be taken when mating the connector, with either a plug or a blanking-plug, to ensure both mating ends are clean and dry.
- Special attention should be given to checking the O-ring for dirt. The O-ring is located under the lock-ring on both the plug and the blanking plug.
- When mating the connector, first locate the plug on its ‘D’ profile, push together as far as possible and then tighten the lock-ring. The action of tightening the lock-ring draws the two mating ends fully together.
- The connector lock-ring needs only to be finger tight. The use of any tools to tighten the lock-ring further is not necessary and could result in damage to the connector.

When operating correctly the Micron Echosounder should be heard ‘ticking’ from the transducer and a small digital readout should be displayed at the top of the Sonar display. When operating in air this should display “50.000m” or “00.000m” depending on the “no-echo” setting of the unit.

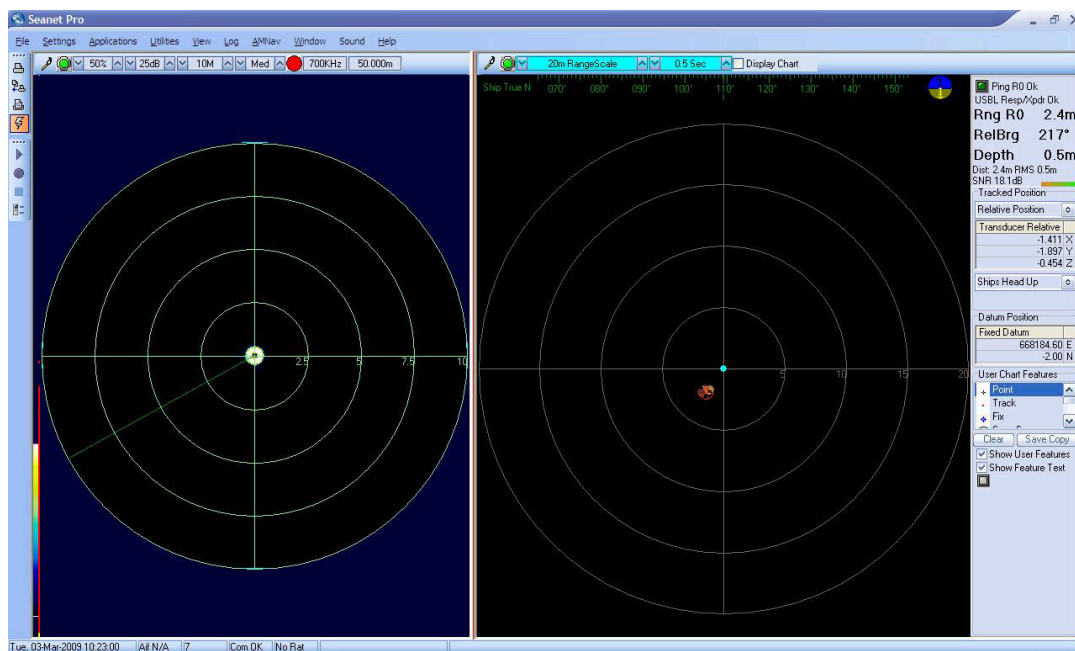

10. Adding a Micron INS

A Micron INS can be used with the MicronNav System and full details of how to configure the two products together can be found in the Micron INS Product Manual (document reference: 0722-SOM-00001).

11. Conversion Between MicronNav Responder and Transponder

11.1. Seagnet Setup for Conversion

Connect the MicronNav100 Hub to the USBL Transducer head and computer and ensure the communications link to the Transponder/Responder is disconnected from Port B on the MicronNav100 Hub.

Connect power to the MicronNav100 Hub and switch it on.

On the computer navigate to `C:\Program Files\Seagnet` and create a shortcut to `Seagnet.exe` on the desktop called `Seagnet Pro Supervisor`.

Right click on the new desktop shortcut and select properties. After the speech marks in the target box enter `-s` ensuring that there is a space between the speech marks and the hyphen.

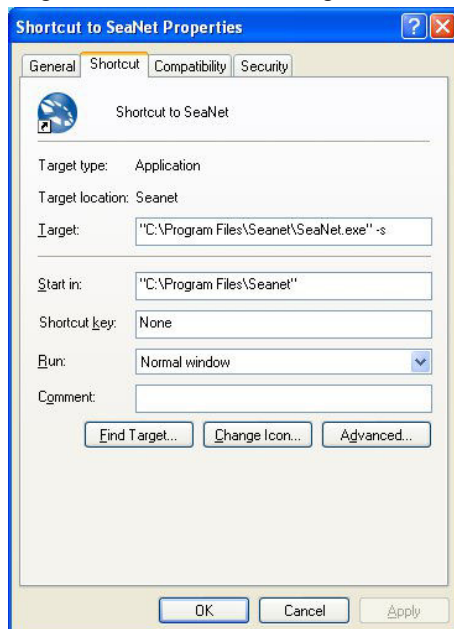

Open up the new shortcut to `Seagnet Pro Supervisor` and select `Setup` from the Applications menu.



The SEAHUBNAV100 and MINIATTSEN device types should be visible in the `Setup` window. The MicronNav100 Hub must now be configured to communicate directly to the Transponder/Responder in order to carry out the conversion. In `Seagnet Setup` click the `Action` column

in the SEAHUBNAV100 row followed by Setup from the drop-down menu that appears to display the SeaHub Setup page. Set Port B to RS232.

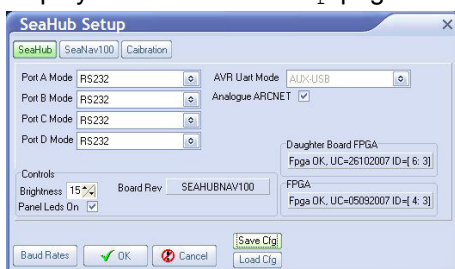

Confirm the settings and close the SeaHub Setup page. After a few seconds, the reprogramming of the unit will be complete and "Node 90, Prog Cfg Done" will be displayed in the status box. The SEAHUBNAV100 table entry will temporarily disappear from the list while the unit resets to activate the change.

Configure the baud rate of Port B by selecting Com Setup from the Utilities menu. Open the Channel Setup page, click on Settings in the SeaHubB row to open the AifSetupForm and adjust the Baud to 57600.

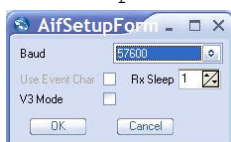

Confirm the settings and close the AifSetupForm.

The Channel Setup page should now list the enabled ports as follows:

Device	Baud Rate	Type
Aif	115200	SeaHubMain
AMNavSeaNavHS	115200	SeaHubHS
Aif	57600	SeaHubE
Aif	57600	SeaHubB

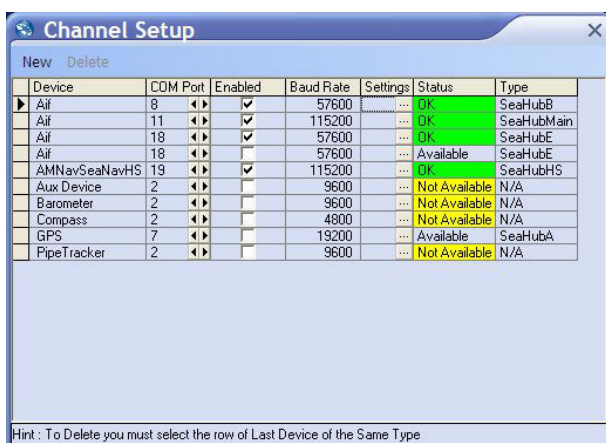

Note

If any other devices are set up on the computer they may also be listed, if this is the case they should not interfere with this operation so should be left alone.

Confirm the settings and close the Channel Setup page.

Switch off the power supply to the MicronNav100 Hub, connect the Transponder/Responder *Main* port to *Port B* of the MicronNav100 Hub. Position a magnet against the body of the unit as shown below and re-apply power to the system.



After a few seconds the unit should be visible in the *Seanet Setup* window (and displayed as *MINIMODEM*). If not try repositioning the magnet slightly and power-cycling again.



The system is now ready for the conversion to take place and detailed steps are explained in the following 2 sections.

11.2. Conversion to Transponder

The Responder unit can now be reconfigured to Transponder mode by clicking on the *Action* arrow button in the *MINIMODEM* row followed by *Setup* from the sub-menu to display the *AM100 ModemCfgSetup* page.



Change the *Unit OpMode* to *Transponder*, *ID Bits* to *IdM 1-16*, *ID Code* to *1* and disable the *COM Rx TMO Enabled* check-box (as shown below).



confirm the settings and close the `AM100 ModemCfgSetup` page. After a few seconds the reprogramming of the unit will be complete and "Node 85, Prog Cfg Done" will be displayed in the status bar.

The magnet can now be removed from the body of the Responder unit and power switched off and re-applied to activate the change. This now completes the conversion from Responder to Transponder mode.

Close the `Seanet Setup` program and delete the `Seanet Pro Supervisor` shortcut.

11.2.1. Enabling the USBL Transducer Transponder Transmitter

Run the `Seanet Setup` program by clicking on the `Seanet Setup` icon from the desktop or navigating to `Setup` from the `Applications` menu of an already running instance of `Seanet Pro`.

Click the `Action` arrow button in the `SEAHUBNAV100` row followed by `Setup` from the drop-down menu. A warning will be displayed, read this and select `OK` to continue to open the `SeaHub Setup` page. Click on `SeaNav100` tab and activate the Transponder transmitter by enabling the `Has Transmit` check box.

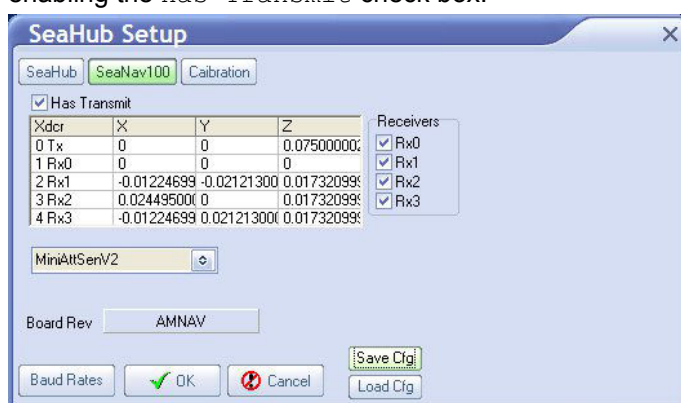

Confirm the settings and close the `SeaHub Setup` page. After a few seconds the reprogramming of the unit will be complete and "Node 90, Prog Cfg Done" will be displayed in the status box. The `SEAHUBNAV100` entry will temporarily disappear from the list while the unit resets to activate the change.

11.2.2. Configure Seanet Pro for Transponder Mode

To configure the `Seanet Pro` software to operate in Transponder mode first run the program by selecting the `Seanet Pro` icon from the desktop. If the screen differs from the screen

shots below, select Sonar Nav from the Applications menu (or Sonar Nav Video if video is also required).

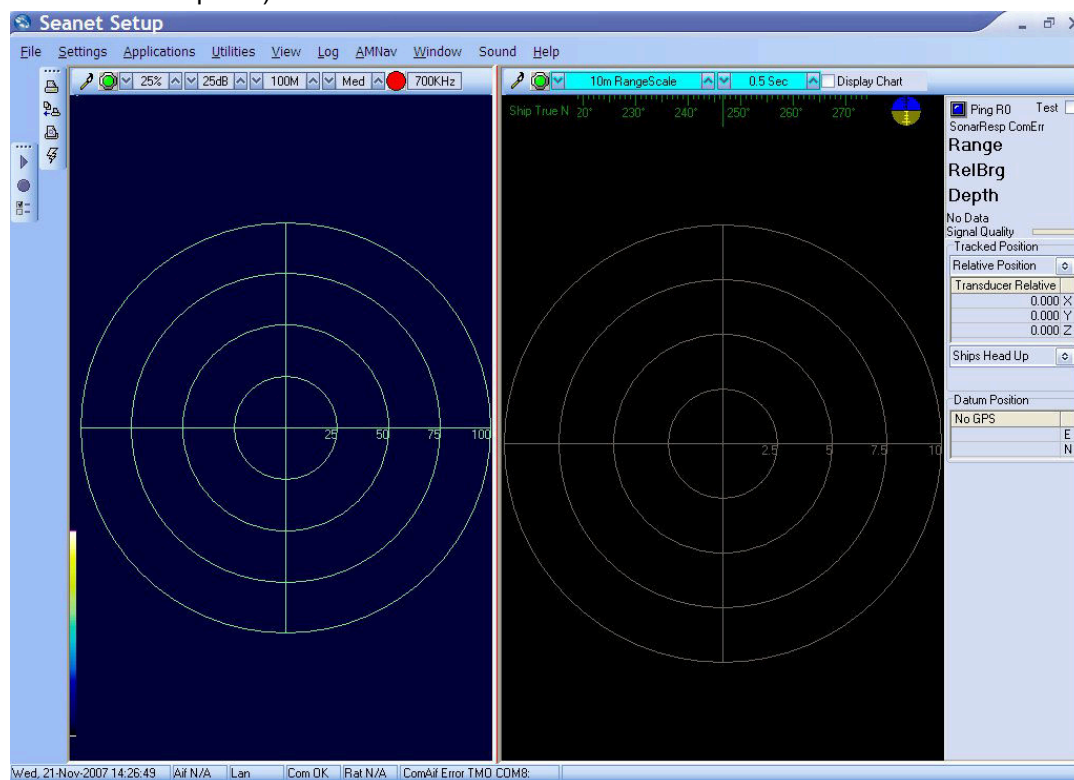

Click inside the tracking window to display the AMNav menu option in the main menu par. Select AMNav from the menu followed by Setup App from the sub-menu to open the Nav Setup page.

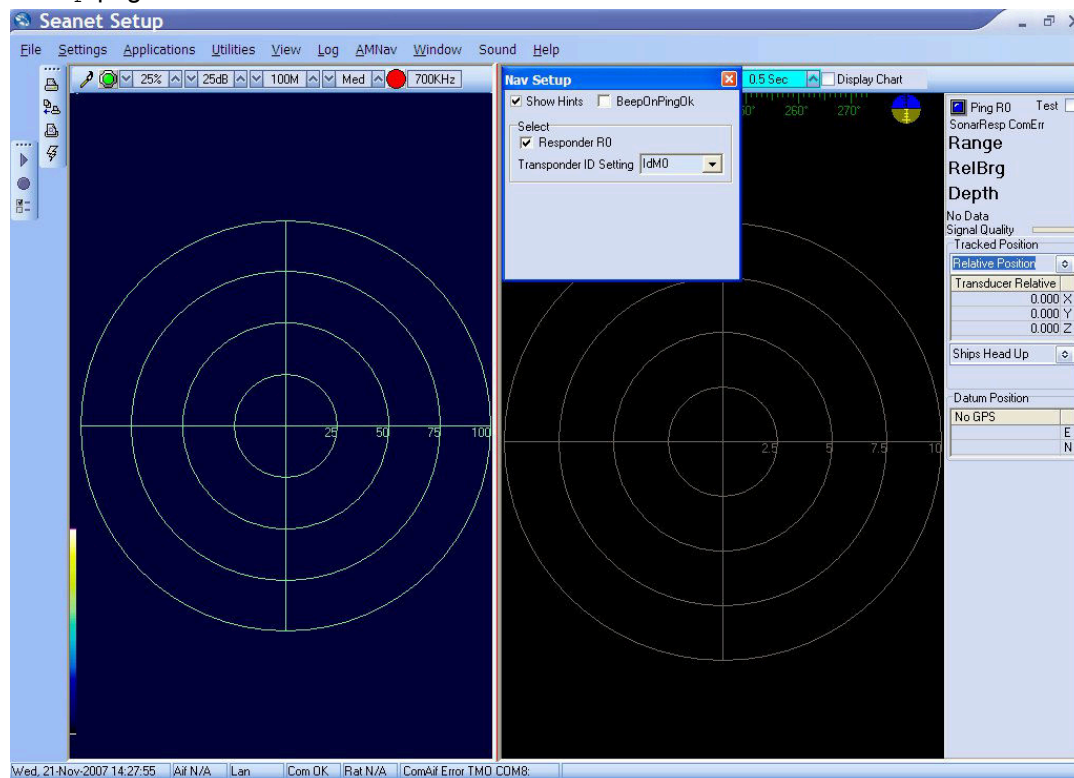

Disable the Responder R0 check-box and set Transponder ID Setting to IdM 1-16 to open the Transponder Selection options. Enable check-box T1.

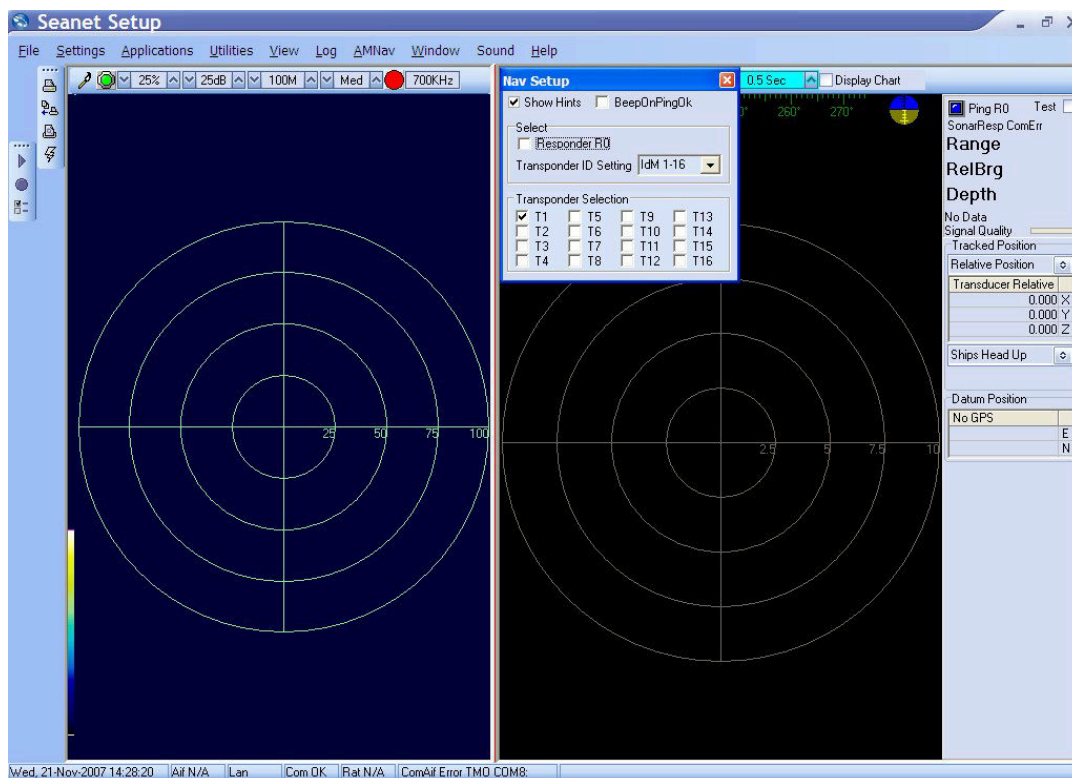

Confirm the settings and close the setup page.

This completes the conversion to Transponder mode. Position the Transponder unit near the USBL Transducer will confirm operation and "Ping T1 ok" should be displayed at the top-right of the MicronNav window.



Note

If not already done so, delete the *Seanet Pro Supervisor* shortcut from the desktop before standard use of *Seanet Pro*

11.3. Conversion to Responder

The Transponder unit can be reconfigured to Responder mode by clicking on the *Action* arrow button in the *MINIMODEM* row followed by *Setup* from the sub-menu to display the *AM100 ModemCfgSetup* page.



Change the *Unit OpMode* to *Responder*, *ID Bits* to *IdM0*, and enable the *COM Rx TMO Enabled* check-box (as shown below).



Confirm the settings and close the AM100 ModemCfgSetup page. After a few seconds the reprogramming of the unit will be complete and "Node 85, Prog Cfg Done" will be displayed in the status bar.

The magnet can now be removed from the body of the Transponder unit and power switched off and re-applied to activate the change. This now completes the conversion from Transponder to Responder mode.

Close the Seagnet Setup program and delete the Seagnet Pro Supervisor shortcut.

11.3.1. Connect the Micron Sonar and Responder

Run Seagnet Setup by clicking on the Seagnet Setup icon on the desktop.

Connect the Micron Sonar to the ROV communications and power supply.

Switch on power to the MicronNav100 Hub and reconfigure Port B to 115200 baud by selecting Com Setup from the Utilities menu to open the Channel Setup page. Click on the Settings button in the SeaHubB row to open the AifSEtupForm and adjust the baud to 115200.

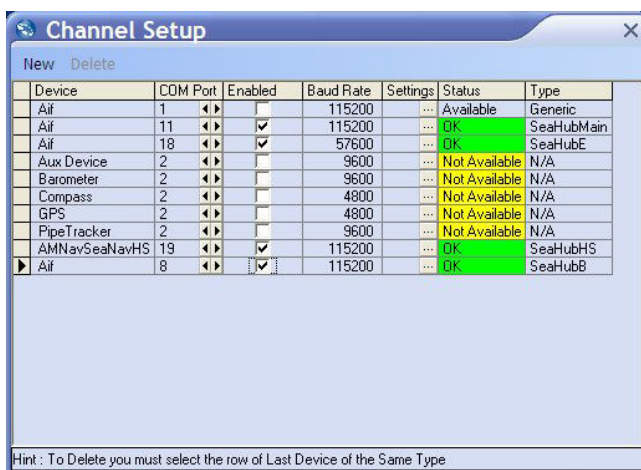

Port B should then be configured to match the Micron and ROV communications type by clicking the Action arrow button in the SEAHUBNAV100 row followed by Setup from the drop-down menu. Set Port B Mode for RS232 or RS485 accordingly.

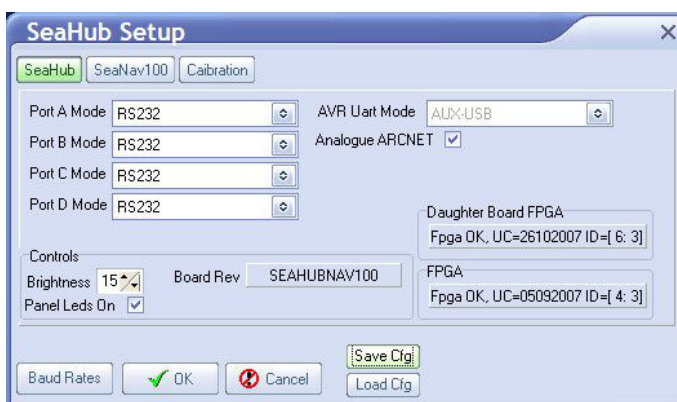

Confirm the settings and close the SeaHub Setup page. Apply power to the Micron Sonar/ROV and once the sonar has initialised the Main Setup page should list three Node numbers in the table - the MicronNav100 Hub (SEAHUBNAV100), the USBL Head (MINIATTSSEN) and the Micron Sonar (MICRON).



The Micron Sonar Aux port now needs to be configured for the Responder unit connection. This is done by clicking the Action arrow button in the MICRON row followed by Setup from the drop-down menu to display the Digital Sonar Setup page.

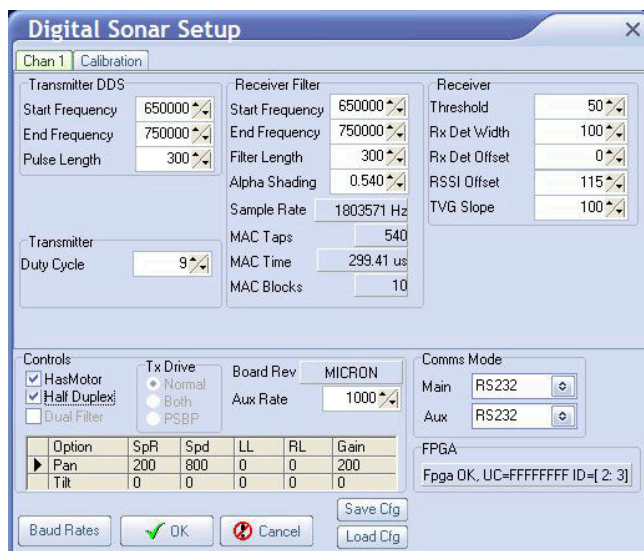

At the bottom-right of the page is the Comms Mode selection panel. Set the Aux to RS232 and click the Baud Rates button at the bottom-left of the page to open the Comms Setup window. Set the Async 1 [Head Aux/Aif Rat] baud to 9600 (for both Lo Speed and Hi Speed).

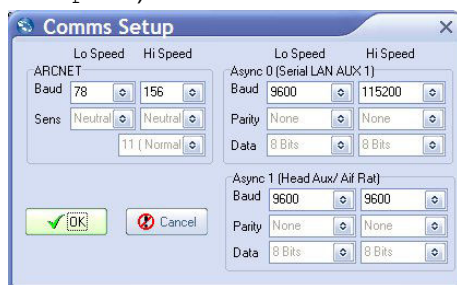

Confirm the settings and close the Comms Setup page and then confirm the Sonar Setup and return to the Seanet Setup page. Remove power from the Micron Sonar/ROV and connect the Aux port of the micron Sonar to the Main port of the Responder using an appropriate interconnect lead.

Switch on power to the Micron Sonar/ROV and check the Micron reappears in the Seanet Setup page. This complete the installation configuration.

11.3.2. Configure Seanet Pro Responder Mode

Run the Seanet Pro program by clicking on the Seanet Pro shortcut on the desktop. The following screens should be displayed but if not navigate to the Applications menu and select Sonar Nav from the list. If video is also required, select Sonar Nav Video

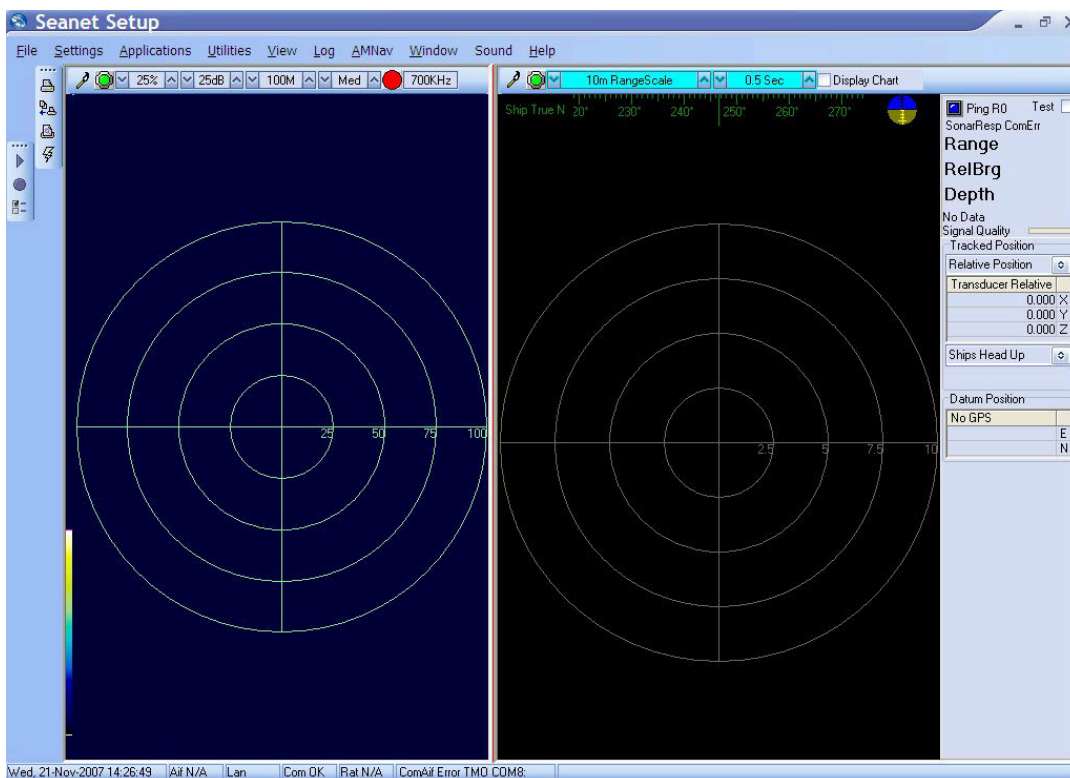

Click inside the tracking window to display the AMNav menu option in the main menu bar. Select AMNav from the main menu bar followed by Setup App from the sub-menu to open the Nav Setup page.

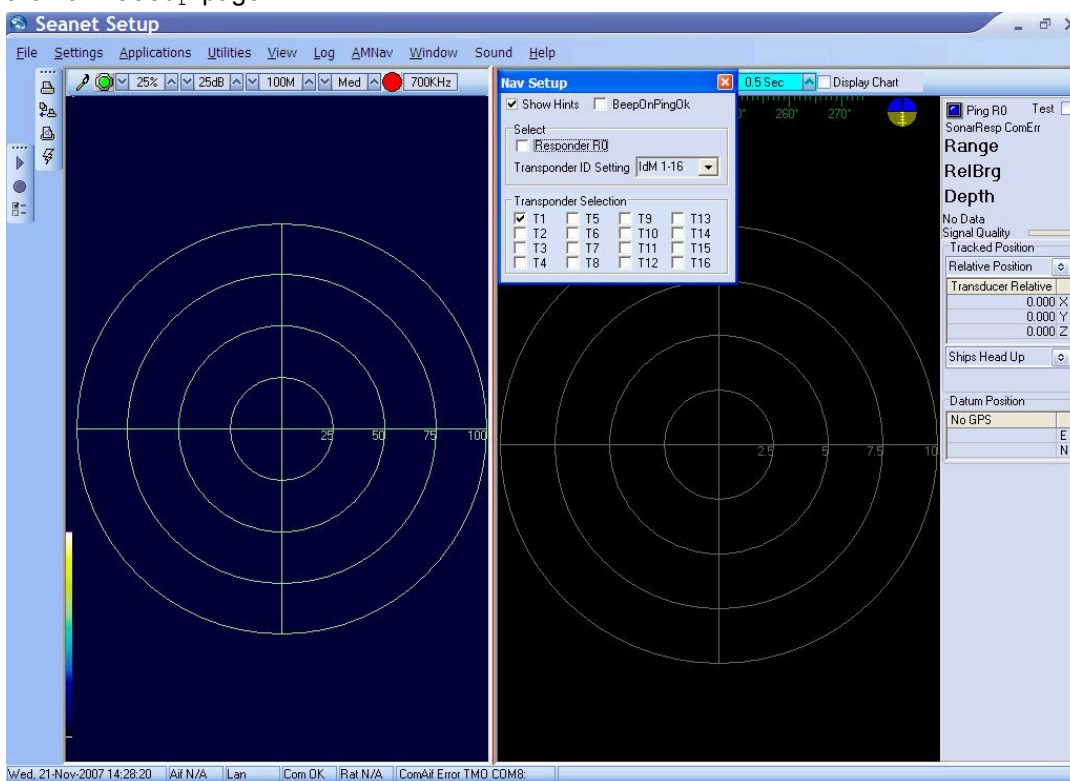

Disable the Transponder T1 check-box and set Transponder ID Setting to IdM0 which will close the Transponder Selection options. Finally enable the check-box Responder R0 (as shown below).

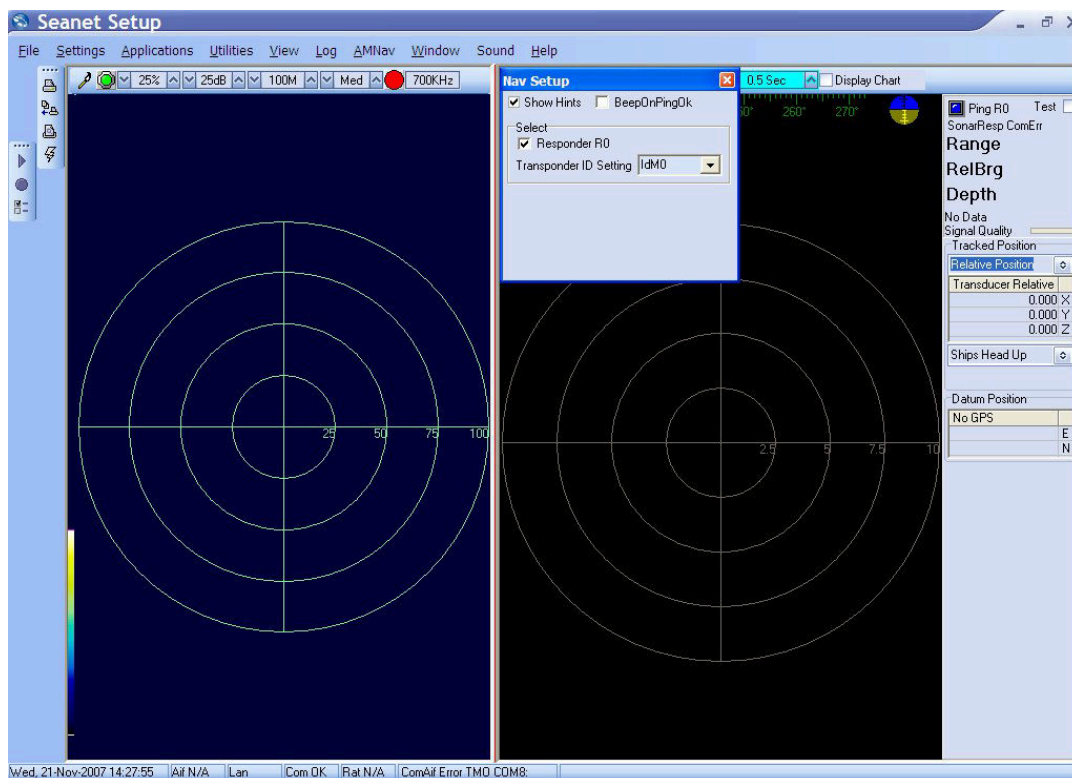

Confirm the settings and close the setup page. This completes the conversion to Responder mode. Positioning the Responder unit near the USBL Transducer head will confirm operation and Ping R0 ok should be displayed at the top-right of the MicronNav window.



Note

If not already done so, delete the Seanet Pro Supervisor shortcut from the desktop before standard use of Seanet Pro

Glossary

.bmp	The standard filename extension for bitmap images.
.mrk	The standard filename extension for marker files exported from Seonet Pro, saved as a text file in tabular format with table cells separated by commas.
.png	The standard filename extension for Portable Network Graphics - a bitmapped image format employing lossless compression.
.tiff or .tif	The standard filename extension for Tagged Image File Format.
.v4log	The standard file format used by Seonet Pro log files.
AC	Alternating Current
ARCNET	Attached Resource Computer NETwork - a network protocol similar to Ethernet but with the advantage of working over much longer ranges.
ASCII	American Standard Code for Information Interchange - a character encoding scheme originally based on the English alphabet.
AUX	Short for "auxiliary".
Bathy	Alternate name for the <i>Tritech International Ltd SeaKing 700 Series Integrated Oceanographic Sensor Suite</i> which outputs data about the conditions of the seawater and water column which may have an affect on the sonar (temperature, depth, etc.,)
CD-ROM	Compact Disc - Read Only Memory
COM	Short for "communications". When used in the context of computers typically it refers to the Microsoft Windows designation of a serial communications port (in this instance it may be given a number, "COM3", for example). In the context of sonar hardware it can be used to refer to the circuit board that controls the communication to the surface.
CSV	Comma Separated Value - a text file in tabular format with table cells separated by commas, usually given the filename extension <code>.csv</code> but this can vary depending on the application.
DA-15	A 15 pin D shaped connector used mainly for the ARCNET connection on the SCU and SeaHub.
DB-25	A 25 pin D shaped connector commonly used for parallel communications on computers and also for connection of the USBL to the MicronNav Hub.
DC	Direct Current
DE-9	A 9 pin D shaped connector commonly used for serial communications on computers.
DIN	Deutsches Institut für Normung e.V. (German Institute for Standardisation)
DST	Digital Sonar Technology
Ethernet	A family of computer networking technologies for local area networks (LANs).

GB	Gigabyte = 1000MB
GPS	Global Positioning System.
IEC	International Electro-technical Committee
JPEG or JPG	Joint Photographics Expert Group - a compression method and file format for image files, files can be stored with either .jpeg or .jpg file extensions
LAN	Local Area Network
LED	Light Emitting Diode
MB	Megabyte = 1000kB
Mbit·s ⁻¹	Megabit per second - data transfer rate equal to 1000 kilobits per second.
MicronNav	An Ultra Short Baseline (USBL) system for location and tracking of ROVs, divers, etc. Consists of the MicronNav 100 surface control unit (similar to the SeaHub but with different functionality) a "dunking transducer" which is mounted on the vessel/dockside under the waterline and a responder which is mounted on the ROV or Hammerhead tripod.
MRU	Motion Reference Unit
NMEA	National Marine Electronics Association - a USA based standards association responsible for overseeing electrical and data communications standards between marine devices (due to become the IMEA or International Marine Electronics Association in 2012).
NTSC	National Television System Committee - an analogue television standard used in most of North America.
OSGB	Ordnance Survey National Grid reference system, a geographic grid referencing system used in Great Britain and its outlying islands.
PAL	Phase Alternating Line - an analogue television colour encoding system.
PC	Personal Computer
PPI	Plan Position Indicator for showing position on the MicronNav software display.
RAM	Random Access Memory
RAT	Remote Access Terminal - the detachable front part of the Trittech Surface Control Unit (SCU) computer. Provides an alternative to using a keyboard and mouse.
ROV	Remotely Operated Vehicle
RS232	Traditional name for a series of standards for serial binary data control signals.
RS485	A standard for defining the electrical characteristics of drivers and receivers for use in a balanced digital multipoint system (also known as EIA-485).

RX	Receive (data)
SCU	Surface Control Unit - a specially manufactured computer which is rack mountable and capable of processing the data from the sonar equipment running either Windows XP Embedded or Windows 7 and Seanet Pro or Gemini software.
SeaHub	An alternative to using a Seanet SCU, this device connects to a laptop or PC via USB interface, essentially this takes the signal from the sonar (in RS232, RS485 or ARCNET) and converts it into a signal suitable for the USB port of the computer.
SeaKing	A specific sonar produced by <i>Tritech International Ltd</i> but also refers to the family of sonar equipment manufactured by <i>Tritech International Ltd</i> comprising of the SeaKing, SeaKing DST scanning and profiling sonars and the Hammerhead survey sonar.
Seanet Pro	The software supplied by <i>Tritech International Ltd</i> which is capable of running all the sonar devices.
Seanet RemV4	A program developed by <i>Tritech International Ltd</i> that runs alongside Seanet Pro and provides remote survey or logging computers with access to data from various devices on the host computer.
TX	Transmit (data)
USB	Universal Serial Bus.
USBL	Ultra Short Base Line (positioning system)
UTM	Universal Transverse Mercator coordinate system - a 2-dimensional Cartesian coordinate system to give locations on the surface of the Earth.
VOS	Velocity of Sound
WGS84	World Geodetic System (1984 revision) - a standard for use in cartography, geodesy and navigation and used as the reference coordinate system by GPS devices.