

applied acoustics

underwater technology



CSP-NP Capacitor Charging Unit Operation Manual



Revision History

Issue	Change No.	Reason for change	Date
A	N/A	First Issue	15/08/19
1	N/A	Production Issue	09/05/22

Table of Contents

REVISION HISTORY	2
SECTION 1 - OPERATIONAL.....	7
ENVIRONMENTAL CONSIDERATIONS	7
SEISMIC SOUND SOURCES AND MARINE LIFE.....	7
1. INTRODUCTION.....	8
2. INSTALLATION	9
SITING THE CSP-NP.....	9
EARTHING	10
INSTALLATION	11
OUTPUT CABLE CONNECTION.....	11
LINE VOLTAGE CONNECTION	12
AC POWER REQUIREMENTS	13
TYPICAL CURRENTS	13
LINE VOLTAGE DERATING	13
240 V MODELS	13
115 V MODELS	13
POWER UP	15
TRIGGER INPUT	15
LOCAL / REMOTE	15
3. OPERATION.....	16
ENERGY SETTINGS	17
OPERATION OF THE CSP-NP WITH A BOOMER SOUND SOURCE.....	17
LOAD SPECIFICATIONS.....	17
BOOMER LOAD	17
SPARKER POWER SETTINGS WITH CSP-NP UNITS	18
DURA-SPARK SOUND SOURCE	18
DUMMY LOAD.....	18
4. OPERATOR CONTROLS AND INDICATORS	19
MAINS POWER SWITCH.....	19
EMERGENCY STOP SWITCH	19
HV OFF/RESET SWITCH	19
HV ON SWITCH	19
MANUAL KEY SWITCH.....	19
KEY POLARITY SWITCH	19
LOCAL / REMOTE SWITCH.....	19
CHARGE RATE SWITCH (LOCATED ON REAR PANEL)	19
EOC (END OF CHARGE) INDICATOR	20

FAULT INDICATOR	20
INTERLOCK INDICATOR	20
TIME OUT INDICATOR	20
HV FAULT INDICATOR	20
LOAD FAULT INDICATOR.....	20
5. CONNECTORS	21
MAINS INPUT	21
REMOTE.....	21
HV OUTPUT	21
TRIGGER INPUT	21
FUSES.....	21
CHARGE RATE SWITCH.....	21
FAN FILTERS	21
6. PRODUCT RECYCLING / DISPOSAL	23
7. SPECIFICATIONS	24
MODELS AVAILABLE.....	24
PHYSICAL SPECIFICATIONS	24
ELECTRICAL SPECIFICATIONS	24
8. SAFETY FEATURES	25
9. OPTIONS	25
SECTION 2 - TROUBLESHOOTING	26
INTRODUCTION	26
10. CIRCUITS AND DESCRIPTIONS	27
SYSTEM OVERVIEW	27
HIGH VOLTAGE SECTION.....	28
HV MONITOR BOARD.....	28
HV DETECT BOARD.....	28
THYRISTOR INTERFACE BOARD	28
HV CHARGER.....	28
AC SECTION	29
CONTROL BOARD AND FRONT PANEL COMPONENTS.....	29
11. CONTROL BOARD	30
KEY CIRCUIT.....	30
KEY BOARD	30
HIGH VOLTAGE / RELAY SWITCHING.....	30
FAULT LATCHES / HV ON CIRCUIT.....	31
12. HIGH VOLTAGE ON CIRCUIT	32
FRONT PANEL BOARD	32
INTERLOCKS / RELAY BOARD.....	33

13. REPAIR AND FAULT FINDING ON CSP POWER SUPPLIES	34
14. CSP-NP BASIC FAULT DIAGNOSIS	35
15. TROUBLESHOOTING GUIDE	38
16. CHANGING A THYRISTOR 'MODULE' IN THE FIELD	41
SECTION 3 – CIRCUIT AND BLOCK DIAGRAMS	42
INTRODUCTION	42
CIRCUIT AND BLOCK DIAGRAMS INDEX	42

Thank you for choosing applied acoustics ltd as one of your equipment suppliers. We hope you experience many years of reliable operational use from our products.



modulus technology ltd carries out all technical support, servicing and repairs. If you have any technical issues with our products please contact the modulus technology team:

Tel: +44 (0)1493 416452

Email: techsupport@modulustechnology.com

Web: modulustechnology.com



Applied Acoustic Engineering Ltd has made every effort to ensure that the information contained in this manual is correct at time of print. However our policy of continual product improvement means that we cannot assume liability for any errors which may occur.



These written instructions must be followed fully for reliable and safe operation of the equipment that this manual refers to. Applied Acoustic Engineering Ltd cannot be held responsible for any issues arising from the improper use or maintenance of equipment referred to in this manual or failure of the operator to adhere to the instructions laid out in this manual. The user must be familiar with the contents of this manual before use or operation.

WARNING

**THIS EQUIPMENT CONTAINS LETHAL VOLTAGES, AND MUST BE
EARTHED AT ALL TIMES.**

ENSURE ADEQUATE SAFETY PROCEDURES ARE EMPLOYED.

Information in this manual is copyright 1993 – 2022, Applied Acoustic Engineering Ltd.
This manual is loaned without other consideration than the agreement and condition that it is
not to be reproduced, copied or otherwise disposed of directly, and is not to be used in whole
or in part to assist in or to furnish any information for the making of drawings, prints, apparatus
or parts thereof.

SECTION 1 – OPERATIONAL

Environmental Considerations

Seismic Sound Sources and Marine Life

Although not proven, there is concern in some quarters that marine mammals may be harmed or their behaviour changed by seismic activity. The sound pulses from sparkers and boomers is much lower in amplitude and higher in frequency (so it will travel less far) than air guns. However it makes sense that a precautionary approach to emitting sounds in the whales and dolphins' natural habitat should be observed.

The CSP energy sources described in this manual have the ability to “soft-start” and increase the energy emitted in the water slowly over time and this technique will give any marine mammals nearby the opportunity to escape before maximum signal amplitude is reached. It will also give them a chance to get used to the noise if they choose to stay (!) rather than being subjected to a sudden shock of a full power seismic signal.

The procedure is quite simple:-

By using a slow repetition rate – say at 1 pulse per 15 seconds and by using the “Auto” charge rate, the energy will slowly increase over the course of several minutes. Once full power has been achieved, the repetition rate can then be slowly increased until the rate desired for the survey has been achieved.

Another factor to consider is to ensure that the start of any survey line is not in such a location that any cetacean is trapped by the vessel and the noise, for example in a small harbour. In such an instance, the survey should start in such a place that any cetacean in the vicinity has a clear and rapid means of escape into open water and away from any unnatural noise source. Further details and advice can be obtained from the following web site: - http://www.jncc.gov.uk/pdf/Seismic_survey_guidelines_200404.pdf. This web site refers to UK waters and relates to air guns as the sound source (in many ways different to a sparker or boomer), but should serve as a useful guide nonetheless.

1. Introduction

This manual covers the CSP-NP model available from AAE. The CSP-NP is based on the highly proven CSP-P, the CSP-NP has a high voltage charger rated at 2000 joules per second, and can supply up to 350 joules of energy per shot into boomer and Dura-spark sound sources. The CSP-NP allows the user to select a greater number of power levels than previous models; this can effectively tune the source to the desired frequency response.

All CSP power supplies across the range incorporate many common parts and can be considered essentially similar with varying power capabilities. All units feature a switchable soft start 'power save' circuit; AVIP (Automatic Variable Input Power) which allows the units to be operated from reduced generator sizes when operating at low output powers.

Traditional high voltage power supplies (bang boxes) charge the energy storage capacitors at a fixed high rate for example at 1500J per second even when the average energy drawn from the capacitors is less; a typical example may be 100 J at 3 pps (300J). This results in a rapid capacitor charge rate for 67 mS followed by nothing, until the next discharge / charge cycle. This charge / no charge operation can often result in generator hunting as the load changes, and may mean that a larger generator is needed than would be the case if the power requirement was averaged over time. By reducing the peak charge rate, the generator hunting is all but eliminated, and a smaller capacity generator is required. The AVIP circuitry will automatically adjust charge rate from 20% to 100% of specification, thus lowering the peak charge rate to just 300 J / second compared to bursts of 1500J/second. The circuitry also features a soft start function, which may take around 20 seconds before the charge rate is ramped up to the correct amount for the task in hand.

The CSP-NP allows the user to effectively 'tune' the boomer sound source to operate at a lower frequency by lowering the operating voltage and increasing the capacitance to supply the correct energy to the sound source. This may be effective in certain instances where more penetration is required.

The CSP-NP monitors the output of the system for open circuit fault conditions and over current fault conditions, limited to approx 4000A.

2. Installation

Siting the CSP-NP

The CSP-NP units can deliver high energy, high voltage pulses, yet still emit minimal electrical emissions, and so can carry the CE mark.

The CE marking ensure that the CSP-NP's can be sited next to sensitive electronic equipment which carry their own CE marking (for susceptibility to emissions) and will be unlikely to cause them interference. However it is often more convenient to locate the CSP-NP's nearer to the back deck and the deployment area so that the high voltage 'output' cable run is minimised.

As high voltages are present, the CSP-NP's must be located away from water spray and condensation, in an environment which is not allowed to become too hot. Care should be taken to allow safe and easy access, and that high voltage cables are out of harm's way. It should also be possible to switch off the unit quickly without having to reach over it!

Ventilation should also be present. All units draw air in from the front and exhaust air from the rear. For operation in high ambient temperatures, the rear cover of the transit case should be removed to allow a good air flow.

If condensation is allowed to develop serious damage may occur. Good room ventilation should be ensured, with no sudden change in temperature (i.e. bringing the unit into a warm room from a cold area) and allow the fans to operate for 10 - 15 minutes before switching on the high voltage.



Earthing

All CSP-NP's MUST be earthed. The M8 earth bolt on the front panel should be connected to the vessel earth by a heavy gauge wire or cable. On larger ships, earth is usually a steel bulkhead, but for smaller fibre glass / wooden vessels a sea earth is necessary. A sea earth can be constructed from a 25 mm² or larger copper cable with 1 – 2 metres of insulation stripped off with the entire exposed copper conductor in the water. A weight will be required to ensure that the sea earth cable is in the water at all time during towing activity even during heavy roll.

It is recommended that earthing arrangements are checked regularly as corrosion or abrasion (or metal cutting gear!) can cause damage which may result in the equipment becoming unsafe from having an ineffective earth.

The CSP-NP range of Capacitor Discharge PSUs is compact and easy to operate. However, the units still generate lethal voltages, and the operators should make themselves aware of all necessary safety procedures. The equipment is designed so that there is no need for the operator to go inside for anything, except major repairs. We cannot be liable for any consequences should the units be opened. Health and Safety guidelines and our own Safety Policy strongly suggest that factory training is received before opening the top cover.

This manual is supplied in three parts:

Section 1	Basic operation information details.
Section 2	For manufacturer trained technicians only and provides troubleshooting advice, schematics and circuit descriptions.
Section 3	Provides block and circuit diagrams.

Installation

The CSP-NP Unit will normally be supplied from the factory in a 'Hardigg' transit case. As is the case with all electronic equipment, care should be exercised in handling. For maximum airflow in high ambient temperatures it is recommended that the anti-vibration housing rear panel be removed. The CSP-NP should be positioned on its base in a dry ventilated area. If the unit is to be operated in very warm ambient temperature (25°C or above), for optimum performance an air conditioned environment is strongly advised. If the unit overheats, it will switch OFF for a few minutes until it is cool.

Although the unit produces minimal interference, and carries a CE mark, it is often good practice to put the CSP-NP away from the navigation and survey equipment and somewhere where cabling to the sound source can be run conveniently and safely. It is this cabling which is the most common source of electrical interference.



EARTHING - FURTHER REMINDER

THIS UNIT MUST BE EARTHED / GROUNDED BEFORE ANY POWER IS APPLIED. FAILURE TO DO SO MAY REPRESENT A SEVERE HAZARD TO BOTH EQUIPMENT AND PERSONNEL.

The front of the CSP-NP must be grounded to the ship's ground system. This is achieved by attaching a short length of thick wire or earth braid from the CSP-NP front panel earth stud, to an appropriate earthing point on the vessel. If a suitable earth cannot be found, the CSP-NP earth stud should be connected directly to the water using an adequate length of heavy wire, with the insulation removed from the submerged end in the water. A weight will also be necessary to keep the wire submerged when the vessel is underway.

Output Cable Connection

ENSURE POWER TO UNIT IS TURNED OFF BEFORE ANY CONNECTIONS ARE MADE. Connect the high voltage cable to the CSP-NP front panel using the high voltage connector. The HV connector has 2 small sensing pins which will deactivate the high voltage if mains power is applied without the connector in place. Ensure the HV connector is fully mated to the unit. The two larger sockets should never be at a high potential but it makes sense never to attempt to touch these.

If you have our HV junction box, the two conductors of the acoustic source - boomer plate or sparker should be connected to this before connecting to the CSP-NP. The terminal wing nuts should be tightened onto clean copper or tinned copper terminals. A good connection is necessary as high currents pass through these terminals. Ensure that the +ve or red terminal is connected to the + mark inside the HV Junction box. The black or -ve terminal should be connected to the - mark inside the HV junction Box. Ensure that the microswitch 'clicks' when the top cover is secured. The HV Junction Box can be bulkhead mounted before the cover is

secured. In the situation of the power cable / sound source being caught on an object, the HV cable is pulled from the HV Junction Box, rather than the CSP-NP unit being pulled onto the floor.

The junction box is usually supplied with a 1.5 metre lead, terminated in our HV connector. The junction box is fitted with a microswitch which is connected to sense pins in the HV plug, ie deactivating the high voltage charger if the lid is removed and the 'INTERLOCK' light will illuminate.

Line Voltage Connection

Mains input is connected by the 3-Pin Amphenol on the left of the front panel. Nominal input voltage is 230VAC 45-65 Hz. The wiring to this connector is as follows:-

A	Ground / Earth
B	Neutral
C	Live

If a ready-wired plug is supplied, it will be supplied from the factory with the following colour coding:-

Green/Yellow	Earth
Blue	Neutral
Brown	Live

The operator must ensure that the ac supply is capable of supplying sufficient energy to power the CSP-NP unit. Although the unit will operate from most generators of 3 kVA, the quality and regulation vary considerably from make to make and how well they have been maintained. We have used 3.5 kVA generators without problems. A voltage stabiliser is not necessary as any reasonable variation of the AC supply will not affect the output voltage (hence power) unlike older designs.

NB Some 'inverter' type generators do not work well with CSP-NP units.

The AVIP technology inside the unit can be utilised to reduce the generator requirements. The CHARGE RATE switch has two positions (Located on rear panel)

OUT : High Charge rate.

The charger delivers the full charge rate (1650 J/sec peak) on demand to charge the storage capacitors.

IN : Auto Charge rate.

The AVIP (Automatic Variable Input Power) circuitry is operational. This adjusts the charge rate automatically to suit the capacitor selection and the repetition rate used, and ensures that a constant current is drawn from the AC mains supply. It is

a soft start circuit and adjusts the charge rate by 5% per sample; a sample occurs each trigger pulse. AVIP will adjust the charge rate from 20% to 98%, thus allowing 100J 3pps operation from a 500 VA generator. Note that it can take up to 16 samples for the charge rate to be set to the correct amount.

AC Power Requirements

Voltage ratings are quoted elsewhere in this manual.

Typical Currents

At 1500J at 1 pps (AVIP out of circuit); Non PFC charger, the following currents apply:-

Voltage	Peak Current	Average Current
110 VAC 50 Hz	28A	19.7A
240 VAC 50 Hz	19.5A	7.9A

(At 60 Hz, the peak currents are slightly smaller)

To see clearly the effect of the AVIP board the following measurements are typical:-

240 VAC at 50 Hz supply. 100J at 1 pps output power

	Peak Current	Average Current
AVIP IN	2.58A	1.06A
AVIP OUT	9.51A	1.11A

Line Voltage Derating

The capability of the HV charger to deliver energy to the load (storage capacitors) reduces with reduced line voltage as the following tables apply.

240 V Models

Line Voltage	Charge Rate
180 VAC	1250 J/second
200 VAC	1500 J/second
210 VAC	2000 J/second

115 V Models

Line Voltage	Charge Rate
100 - 115 VAC	1300 J/second
116 - 130 VAC	>1500 J/second

You may notice that the low line voltages above are below those specified in the rear of this manual under 'specifications' The above tables denote the ability of the charger to perform under certain line voltage conditions, and not the complete system. We do not recommend operating the CSP-NP units below the minimum voltages listed in the specification section of this manual.



FURTHER REMINDER

If the unit has recently been moved from a cold environment to a warm one, condensation may have developed, which may cause arcing in high voltage equipment. The operator is advised to switch the unit on and run the fans for 10-15 minutes before allowing the high voltage to be switched on. This will allow the unit to warm up to the room temperature, and any condensation will disperse.

Power Up

When suitably connected to ground, the transducer and AC mains, and the transducer is in the water, the power can be applied using the ON / OFF switch and circuit breaker. The fans will run, and the HV OFF / RESET button will illuminate. Select the appropriate power output required and press the RESET button to reset the internal circuitry. Press the HV ON button: there will be a small delay before the HV relays engage, and then the high voltage will come on as indicated by the illuminated HV ON switch. Any changes in system parameters (such as power change) will cause the HV to switch OFF, and the unit will need to be RESET before the HV can be switched on again. If the INTERLOCK indicator illuminates, check the HV plug / HV junction box.

Trigger Input

Trigger input is by BNC connector. The unit accepts +ve trigger (triggers on rising edge) 5 - 20 volts. Opto-isolated, or by contact closure, as controlled by the KEY switch. (OUT for +ve key, IN for contact closure.) The manual key button can be used too and this also shows, by illumination, when a key pulse has been accepted. (A lockout circuit limits the unit to around 6PPS maximum.)

Local / Remote

The LOCAL / REMOTE switch allows connection of remote box for operation from the laboratory or instrument room. Using the remote box is achieved by turning the LOCAL / REMOTE switch to remote. The high voltage can only be turned on from the instrument room and *not* from the CSP-D Unit. The high voltage OFF button is operational from the CSP-D Unit *and* remote box. The CSP Unit can also be keyed from the remote box via a BNC socket. The remote also monitors the status of the key detect circuitry, and the key LED will only illuminate on reception of a valid key pulse within the CSP-D itself, thus the operator can also see if the interconnection cable is OK. The remote also has a FAULT LED, as well as high voltage ON and high voltage OFF indicators.

LOCAL Operation indicated by LED on – Switch OUT.

REMOTE Operation indicated by LED out – switch IN

3. Operation

Operation of the CSP-NP is similar to previous versions of the CSP.

Installation check-list:-

- a) The sound source (boomer plate or sparker) has been connected and that it is in the water.
- b) A key pulse is connected – either through the front panel BNC connector or through the remote input.
- c) A good earth has been connected from the ‘Safety Earth’ bolt on the front panel preferably to both the ship and a sea earth.
- d) AC mains is connected to the ‘Mains Input’ connector.
- e) A safety check has been carried out to ensure that there is no-one in the water and that crew members know that the unit is about to be operated.

Once switched on, the ‘HV OFF / RESET’ button must be pressed to reset any fault latches and the light behind the ‘Manual Key’ button is flashing in sequence with the key input signal. The output power can now be selected by using the Power Select rotary switch. The HV / RESET light will illuminate upon a change in power setting press reset if required. Once the appropriate setting has been made, the HV can be energised – press the ‘HV ON’ button.

A series of up to 2 clicks will be heard depending on the energy selected as the relays switch in circuit. Once these relays have engaged, the high voltage is enabled. The HV ON lamp is illuminated followed by the End of charge lamp. This indicates that the HV is ready to be discharged into the local load upon reception of a key pulse.



If either of the power level switches is moved or if the HV off/reset button is pressed, the unit will shut down safely. In an emergency, the red ‘STOP’ button can be pressed.

The maximum repetition rate is governed by the charge rate (1500 Joules per second) and the amount of capacitance selected. For example, at 300J / shot the CSP-NP models will run at 4 PPS, allowing for system overhead time.

Energy Settings

CSP-NP	
SWITCH POSITION	OUTPUT POWER
1	50J
2	100J
3	150J
4	200J
5	250J
6	300J
7	350J

Operation of the CSP-NP with a boomer sound source

A boomer plate as a sound source produces a single pulse and the amplitude and duration of this pulse is controlled by the energy going into it. The energy is derived from the voltage and the quantity of energy stored in the CSP unit. The voltage applied varies from 2.5KV to 3.9KV across the range using 2 capacitors.

Load Specifications

The CSP-NP units are designed to deliver high currents into boomer or sparker type loads. The loads are quite different in make-up.

Boomer Load

A boomer plate consists of a coil imbedded in an epoxy or plastic material and thus by its nature is an inductive load. The inductive 'kickback' is controlled by circuitry inside the CSP. Typical currents into a boomer plate are listed below:-

Energy (HI)	AA200 Plate	AA301
100J	800A	900A
200J	1050A	1200A
300J	1250A	1350A

The currents will vary according to the length and type of cable used between the load and the energy source. Note that the CSP-NP units are specified for AAE boomer plates and have not – to date- been tested with any other type.

Ensure that the energy and repetition rate do not over drive the sound source.

Sparker power settings with CSP-NP units

Dura-spark Model Number	Typical Input Energy (Joules)
Dura 40	200J

Dura-spark Sound Source

A sparker consists of a number of electrodes in the (salt) water which creates a sound pulse as the plasma bubble expands. The current into a sparker varies with cable length and type as well as by the number of tips and the salinity of the water. Typical values are shown below for AAE sparkers in standard seawater with a salinity of 35 ppm.

Energy	Dura-Spark 40 (40 tips)
100J	800A
200J	1500A
300J	2500A

Dummy Load

AAE manufacture a dummy load with precisely designed characteristics which can be used for testing of CSP-D units in the workshop to avoid 'water based dummy loads' such as dustbins full of salt water etc!

4. Operator Controls and Indicators

MAINS POWER Switch

Double pole switch that also acts as an over current circuit breaker. It is situated by the mains input connector. The switch has standard O I positions.

EMERGENCY STOP Switch

In the event of an emergency the unit can be shut down. This switch shuts off the control logic of the charger thus disabling the system. Rotate to reset.

HV OFF/RESET Switch

Needs to be pressed if fault occurs, or if someone has tampered with the controls. This button also operates as the HV OFF button. Press to switch OFF.

HV ON Switch

Switches in capacitors and HV PSU, (note delays on switching), switch illuminates when the high voltage is switched on operated in conjunction with the HV ENABLE key switch, thus to switch HV ON, HV ENABLE needs to be enabled simultaneously.

MANUAL KEY Switch

Triggers CSP unit when pressed. Also illuminates when an external key pulse is detected

KEY POLARITY Switch

Used to select either:

+ve key pulse (3.5 – 20 volts, opto isolated triggers 0.5 mS from rising edge), or contact closure (triggers 0.5 mS from falling edge or closure - not isolated).

LOCAL / REMOTE Switch

Controls whether an external remote box can be used, as marked on the front panel.

Note that the unit can be switched off from the front panel and the remote at any time.

CHARGE RATE Switch (Located on rear panel)

As previously described, this switch selects the AVIP circuitry or full charge.

Recommended position: IN (AVIP Engaged)

EOC (End Of Charge) Indicator

LED illuminated when the storage capacitors have reached their potential voltage (~2.5 to 4 kV). In this way the operator can see if the unit is being run faster than the charger can cope with. If the operator notices loss of data on the recording system, it may mean the CSP-NP is being fired too quickly, not allowing the capacitors to charge to their full potential. Slowing the repetition rate down until the EOC LED flashes will ensure the appropriate voltage is reached across the storage capacitors, also the correct energy is being discharged in the sound source.

FAULT Indicator

This indicator will normally illuminate when the unit is powered up, and will extinguish when the RESET button is pressed. It will otherwise illuminate during most faults. Please note that the fault light will not illuminate if the thermal cut-out operates in the charger module.

INTERLOCK Indicator

Illuminated if front panel connector is left out when the unit is switched ON or if the lid of the HV junction box has not been closed correctly. The interlock LED will also illuminate if the top cover is removed. You will need to press RESET once the interlock condition has been cured.

TIME OUT Indicator

For safety, the HV is switched OFF after a period of approximately 25 - 30 seconds without key. This also helps preserve the capacitors, as all pulse discharge capacitors are not designed to sit powered up indefinitely.

HV FAULT Indicator

Indicates an output overvoltage, (possibly due to an open circuit capacitor), temperature fault or low input voltage condition.

LOAD FAULT Indicator

Indicates an HV Output over current or open circuit condition. The indicator will be illuminated together with the HV OFF LED for 10secs before resetting.

5. Connectors

Mains Input

200 – 250 VAC mains input. Connection details are supplied elsewhere in this manual.

Remote

Allows operator to remotely control CSP-NP.

HV Output

4 pin proprietary connector. Using our HV2 plug, the large connector pins are proof tested to 6000 volts and can operate with current pulses up to 6000 amps. The two small pins are used as interlock pins. If these are left open circuit, the CSP-NP will not be able to enable the high voltage (INTERLOCK fault).

Trigger Input

The trigger input is connected via a BNC socket.

Rear Panel

Fuses

The rear panel contains 2 fuse holders, and these are the only things we recommend the operator checks if he has not received factory training. The fuses are rated as follows:-

F1	3A Antisurge 1¼"	(240V)	7A Antisurge 1¼"	(110V)
F2	3A Antisurge 1¼"	(240V)	7A Antisurge 1¼"	(110V)

Charge Rate Switch

(see text).

Recommended position is OUT to make use of the AVIP circuitry.

Fan Filters

These filters should be periodically cleaned to ensure maximum air flow. This can be done with a small stiff brush.



SAFETY NOTICE

All interlocks and safety features are doubled. For example, if the HV connector is removed, the HV is shut OFF by the logic board which controls the charger module AND the high voltage is switched OFF by a separate relay. The interlock circuit operates from its own isolated 12V supply and operates 2 relays, as well as the control electronics. However, it cannot be stressed enough that the operator and all those who might come into contact with this equipment treat it with extreme caution and should not take any safety feature for granted.

The unit should be disabled by removal of the mains lead or the HV Plug before any attempt is made to make any wiring changes or inspection of the load. Despite being heavily insulated, the HV cable should not be touched or held when the unit is operating. The load should always be in the water before operation. Crewmembers should be made aware of these facts during mobilisations.

6. Product Recycling / Disposal



Within the UK, all electronic components and batteries must be taken for separate collection at the end of their working life under the Waste Electrical and Electronic Equipment (WEEE) Regulations 2013 and Waste Batteries and Accumulators Regulations 2009 respectively. The AAE Technologies Ltd group (AAE Tg) of companies as UK manufacturers will responsibly dispose of any returned end of life AAE Tg components/batteries through registered/approved recycling schemes. In order to prevent uncontrolled waste disposal and promote recycling, please contact Technical Support for a RMA number and return any end of life items (if safe to do so) carriage paid by the sender to our UK head office

7. Specifications

CSP-NP Capacitor Discharge Power Supplies

Models Available

CSP-NP : 2000J/s at up to 350J/shot.

Physical Specifications

CSP-NP	Size	: 19" Rack Mount 4U high excluding shock mount housing.
	Weight	: 22 kg (Supply Only)

Electrical Specifications

Mains Input	:	207 - 260 V 1 phase.
	:	45 - 65 Hz
	:	3-Pin connector.
Voltage Output	:	2700 to 4000 volts DC.
Output Power	:	50 to 350J
		By 4-Pin connector (Power and interlock).
Selection	:	Rotary switches.
Trigger	:	+ve key (+5 to 25V rising edge) opto isolated or contact closure. Set by front panel switch.
Discharge Method	:	Semiconductor module.
Maximum Current	:	A current sensor ensures that the unit shuts down beyond approximately 4000 Amps although the thyristor module can exceed this.
Remote	:	10 way Amphenol.
Earth	:	M8 stainless stud on front panel.

8. Safety Features

Should any fault develop, the high voltage PSU (Charger) and all capacitors (which have bleed resistors) are individually dumped to ground, until the system is reset. A double layer of safety cut-outs ensure that partial failure results in system shutdown.

Interlocks	: Dumps high voltage when fault develops.
Time Out	: Shut down after period (~30 seconds) without key pulse.
Local/Remote	: Disables remote (if fitted).
Load	: Shuts down HV upon open circuit load or load over current.
Reset	: Resets unit after fault or if interlock activated.
Open circuit detect	: Disables firing when an open circuit load is present.
Output current detect	: Shuts unit down if current exceeds a pre-determined level.
Thermal shut-down	: HV charger shuts down if it overheats. HV Discharge semiconductor thermally protected – unit will shut down if overheats.

9. Options

Remote	: Allows operator to control unit at a distance. Includes key pulse line.
Junction Box	: For connection of standard transducer cables to HV connector.
Shock Mount Housing	: For transportation and operation. (Recommended.)
Transit Case	: For storage and transportation. Foam lined.
Field Spares Kit	: For trained technicians only. For servicing units in the field.

Although correct at time of printing, these specifications are subject to change without notice.

SECTION 2 - TROUBLESHOOTING

Introduction

The CSP-NP Units have been designed so that the operator does not need to remove the top cover for any usual adjustments. The top cover should only be removed by factory trained personnel, and the following points should be noted.

The safety features have been over-engineered for safety, but should not be relied upon:-

- An earth wand - connected to the front panel ground and ship ground should be used to ensure any high voltage inside the unit is dissipated.
- Call the factory for advice if you are unsure about anything!

An earth wand can be supplied if required.

10. Circuits and Descriptions

The following pages give brief circuit descriptions for major items inside the CSP Unit itself. The descriptions should be read in conjunction with the diagrams (Schematics).

System Overview

The control board handles operation of the complete system and can be considered to be electrically the 'heart' of the unit. It controls the operation of the charger with various control lines, as well as switching the storage capacitors in and out of circuit; driving the triggering module for the thyristor and accepting safety information from interlock switches such as the controls on the front panel connector. As a back-up to this board, a separate 'layer' of control electronics - relays from an additional isolated supply - are used to disable the capacitor charger supply.

The CSP-NP Unit is designed for minimal operator intervention. The term, 'No user serviceable parts', does really apply!

Access to the inside of the unit is initially through the top cover. Ensure that the AC supply is disconnected - remove the AC plug from the front panel and then remove the lid securing screws. Note that one of these is longer than the rest. It is this longer screw which controls the lid interlock switch mounted on the left-hand side plate. There are quite a number of screws for the lid. This is a feature recommended by UK HSE (Health and Safety Executive) to deter easy access to the unit! It also is part of the electrical shielding of the system.

Once the lid is removed, access to the high voltage parts is achieved. We remind the reader that we cannot be responsible for any errors or omissions by the manufacturer or any errors by the operator after the top cover has been removed.

High Voltage Section

The right side of the unit contains the high voltage parts. Each capacitor is switched in and out of circuit by 12 kV rated, spring relays. The relays use a rotating moving contact which is silver plated. The fixed contacts can be rotated in the event of wear. When disconnected, the capacitors are discharged through the relays to ground via 10k Ω resistors, which are mounted on a circuit board on the RH panel. Although physically small, these resistors can handle 2000J pulses at well in excess of the rated voltage of the unit. It should be noted that the average power these resistors can tolerate is 6 watts. Repeated discharge of the capacitors into these components will cause them to fail.

A specially designed high current thyristor switch is used in the CSP-NP, interfaced to the control board by an interface board. This is held in place with an isolated clamp arrangement manufactured from Nylon 66.

Note: All models operate at approx 4KV.

HV Monitor Board

Using a current sensor the HV monitor circuitry monitors the output current to prevent excessive load currents damaging components. The circuitry also monitors the HV voltage to detect open circuit load conditions where the energy has not been discharged. Upon detection of the above faults the board flags a LOAD fault to the control board, this fault is automatically reset after 10secs in order to warn the operator of a possible fault with the load thus preventing damage to internal circuitry.

HV Detect Board

This board using a HV resistor voltage divider via opto isolator provides voltage feedback to the HV Monitor board on the charge status of the capacitors to detect an open circuit fault condition. The board also contains diodes to protect the output bridge of the charger from reverse voltage swing. There is also a set of high current diodes which are used to limit the amount of reverse voltage swing on the output of the unit.

Thyristor Interface Board

This board provides an interface between the control board and the thyristor by providing an isolated 5V supply and switching the 12V CMOS trigger pulse down to 5V TTL.

HV Charger

The HV Charger is fitted in the middle of the chassis and runs from the rear to the front of the unit. The charger is designed as a module, and we would not expect that field servicing could be carried out on this unit.

Connections:- L2 - LINE
 COM - NEUTRAL
 GROUND

AC Section

The AC Section is to the left of the charger. Access to it can be gained by firstly removing the top plate and by lowering the left hand side panel.

Once the LH panel has been removed you will see (from back to front) the AC mains filter, a 90-250VAC 12VDC power supply, 2 control relays and a separate 12 V power supply for these relays. Input fuses can be found on the rear panel :-

F1	3A Slow blow 1¼"
F2	3A Slow blow 1¼"

F1 Protects 12v power supply

F2 Protects the relay board and line voltage powering the high voltage relays, also the front panel fans.

Control Board and Front Panel Components

The control board is mounted on left hand side panel.

Descriptions of the control board and the front panel items - such as power selector switch and display board are detailed later in this section.

The *Troubleshooting Guide* can be used to assist the operator in identifying any malfunction.

11. Control Board

Key Circuit

Drawing No CSP1000-5000 Section 3.

Key Board

Drawing No CSP1000-5003 Section 3.

The power supply can be triggered using any of the following:-

1. *Key in* is via the BNC connector on the front panel. The key source is opto-isolated, and this can be either a pulse (3-24VDC) or a contact closure, selectable using the key polarity switch on the front panel.
2. *Remote key in* is via the remote box and cable (3-24VDC positive key only). Key source is opto-isolated from the power supply.
3. *Manual key* - each time the switch is depressed.

The Key In / Remote Key signal is applied to the key board optically coupled via OP1 and OP2 to IC1A on the control board. IC1A generates a 150mS delay preventing repetition rates in excess of 6 times per second. The output of IC1A triggers IC1B which produces a 1mS pulse to key the trigger board via the driver IC4.

IC2 is configured as a *time out* alarm. If there is no key input after 20.25 seconds, the Fault / Time Out LEDs on the front panel will illuminate and the high voltage will be disabled.

A 50mS pulse is generated via IC8A inhibiting the high voltage charger during and after the firing of the SCR. IC4 is also used to drive the HV ON / OFF and Key LEDs on the remote box.

High Voltage / Relay Switching

Drawing No CSP1000-5000 Section 3.

The high voltage capacitors are switched in / out of circuit using the Output Power Switch located on the front panel. The power select switch is connected via the front panel board to IC3 on the control board. When the high voltage button is pressed, (providing no fault conditions occur), an 0 on any of the switch inputs will allow that capacitor to be placed in circuit.

For Capacitor 1 in the diagram; with no fault latches activated, IC11D O/P is high allowing 11A O/P to be high. IC9A generates a ½ second delay before allowing relay RLA to close via IC10A. RLA closing connects mains VAC to the high voltage relay, switching the HV capacitor in circuit.

IC7B produces a 3 second delay after the high voltage button is pressed, before the HV is activated. Relay RL1 controls the HV ON / OFF in the charging unit. ICs 9A, 9B, 8B and 7A all provide a small time delay, (less than 3 seconds), allowing the HV capacitors to be in circuit before the charger high voltage is connected. The sequential delays for switching these relays is to ensure large current pulses are not drawn from the toroidal transformer.

Fault Latches / HV on Circuit

Drawing No CSP1000-5000 Section 3.

A reset / fault condition can occur due to any of the following:-

1. High voltage connector to transducer not being connected while power supply is switched ON.
2. The top cover has been opened or left OFF with power supply switched ON.
3. The power supply has not received a key for approximately 20 - 25 seconds.
4. The output power switch has been changed.
5. A failure on the 12V logic supply.
6. A fault has occurred with the high voltage diodes.
7. There is a short or open circuit on the output cable or load.

If the high voltage connector is disconnected or top cover left off, the mains relay located under the left side panel will open, disconnecting mains to the charger. (See Relay Board, Section 3)

Any high voltage within the charger is then dumped via an internal resistor network. The input to IC5A via opto-isolator OP4 will go high, setting the RS latch. IC5 output is fed to IC6 (8 input OR gate). A logic 1 on any of the inputs will activate the OR O/P, Pin 1. This resets IC5D, which holds the O/P of IC11D low.

With IC11D O/P low, all the capacitor switching relays RLA-D (see HV / Relay Switching Circuit) are deactivated. Any high voltage relays in circuit will open, discharging the high voltage capacitors to ground via 10K dump resistors situated on the right side panel.

IC11D O/P at logic 0 also stops the key to the trigger board via IC4 Pin 8 and disables the charger ON / OFF relay RL1 by resetting IC7B.

The O/P from the time out alarm IC2 is fed to IC6 via RS latch IC5B. An input to IC6 is also provided from the front panel board resetting the system if the power select switch is operated independent of high voltage status. (Reset circuit shown on front panel board.)

The HV OFF / RESET switch on the front panel connects to IC6 via IC3C. The fault LED situated on the remote box is controlled by D3/D7 acting as a diode OR gate, with Q2 as driver transistor.

If there is an open circuit in the high voltage diodes situated on the RHS panel, the high voltage will switch off and keep resetting until the diodes have been replaced. The same fault condition may occur if there is a short circuit on the output cable or in the sound source itself. A current monitor circuit disables the high voltage charger and resets IC6 via Pin 11.

12. High Voltage on Circuit

The high voltage can be activated from the power supply front panel, or remotely from the instrument room using the remote box and cable. Both switches are controlled using the Remote / Local (R/L) switch on the front panel.

With the switch in local the high voltage can only be operated from the power supply front panel, disabling the remote HV ON button.

If the R/L switch is in remote, the power supply can only be operated from the instrument room, also disabling the front panel HV ON button. The high voltage OFF button will still operate regardless either from the front panel or on the remote box if pressed.

The HV ON switch is connected to IC5D on the control board. Providing there is no fault condition, RS latch IC5 is set, sending its O/P high. The 8 input OR gate IC6 also has a NOR function Pin 13. With no faults or resets (logic 1s) on the I/P, the NOR O/P on Pin 13 will be high sending the O/P of AND gate 11D high. This will then allow any high voltage capacitors to be switched in circuit via the HV relay control circuit.

IC7B is also triggered, generating a 3 second delay before the high voltage from the charger is activated.

Front Panel Board

Drawing No CSP1000-5004 Section 3.

The front panel (FP) board contains driver circuits for LEDs on the CSP front panel. Most of the panel switches are connected to the control board via the FP board.

The HIGH VOLTAGE ON and EOC (End Of Charge) LED inputs, are controlled directly from the Charger. OPI/2 provide isolation between the FP board and the charger.

The output power switch is monitored by a reset circuit comprising IC1 (4 I/P OR gate) and IC2 (RS latch). Whenever the O/P power switch is operated, one of the inputs to IC4 will go high, sending the output high and setting the RS latch. The output is connected to the HV OFF / RESET circuit on the control board, which will then reset the CSP power supply.

Interlocks / Relay Board

Drawing No CSP1000-5002 Section 3

The mains input for the high voltage charger is routed via a contactor controlled from the relay board located under the left side panel. A small mains transformer and rectifier provide 12VDC to operate the contactor relay.

Mains to the transformer is connected via a microswitch situated on the left side panel. The microswitch disconnects power to the transformer when the top cover is removed. With the cover off, the charger has no mains power connected.

TO ENSURE CORRECT OPERATION OF THE POWER SUPPLY, THE TOP COVER MUST BE SECURED IN PLACE. A special 20mm hex screw is provided to operate the microswitch, THE 20MM SCREW NEEDS TO BE PLACED IN THE FRONT POSITION ON THE TOP LEFT HAND SIDE OF THE UNIT.

FAILURE TO SECURE THE COVER USING THE 20MM SCREW WILL RESULT IN A FAULT CONDITION ON THE FRONT PANEL OF THE POWER SUPPLY!

The 12VDC output from the rectifier is connected to the relay via an interlock on the high voltage socket. With the high voltage connector removed or disconnected, the relay is de-energised, disconnecting mains power to the charger.

FOR CORRECT OPERATION OF THE POWER SUPPLY, THE HIGH VOLTAGE CONNECTOR MUST BE FITTED AND TOP COVER SCREWED DOWN.

If the top cover or high voltage connector is left off, the FAULT and INTERLOCK LEDs will illuminate on the CSP front panel, resetting the system.

A second contactor relay will disconnect mains power to the high voltage charger, if a problem occurs in the 12VDC logic supply to the control and front panel boards.

13. Repair and Fault Finding on CSP Power Supplies

It is not recommended that any internal repairs are undertaken to any CSPP by anyone other than a suitably qualified engineer. AAE can take no responsibility for loss or injury caused by repairs that have not been performed either within our own Laboratories or by our own registered service agents.

During diagnosis procedures it is recommended that the power selection switch is placed at 50J and a suitable Transducer or Dummy Load is attached to the output.



SAFETY NOTICE

It is also imperative that the HV Charger main supply is disconnected when any adjustments are made within the unit.

Even with the supply disconnected lethal voltages may be present, so use extreme caution when making any adjustments or measurements.

Make sure that a responsible assistant is present to prevent people from walking into the service area. They should also be capable of taking the correct actions in the event of an emergency.

Try to keep one hand in your pocket at all times and wear non-conductive footwear.

IF IN DOUBT / DONT

14. CSP-NP Basic Fault Diagnosis

Unit Dead

First check the integrity of the mains supply fuse and the mains supply itself, if the fuse itself has blown try the following components:

Mains Circuit Breaker?

Input Mains Filter?

Damage to the input power wiring?

Unit Fans Operate, but no front Panel indicators

Check fuse 1 on the rear panel, (this is the supply fuse to the internal 12V PSU), if O.K try the following:

Internal wiring to the 12V PSU

Replace the 12V PSU

12V PSU O.K., But still no front panel indicators

Ensure that LED 3 on Control Board is illuminated, if not, suspect the following:

Wiring between 12V PSU and the control board

If LED 3 is illuminated

Replace Control Board

Replace Front Panel Board

Check interconnect wiring between these sub-assemblies

Fans Do Not Operate

Check integrity of Fuse2 on rear panel, if O.K. :

Check Mains Wiring To Fans

Check Wiring to Relay Board

Fans Operate, But Pronounced Delay between Power Up and Front Panel Illumination

Replace 12V PSU

Unit Powers up Normally, Fault Lamps do not go out on pressing Reset

Ensure Interlock screw is present in top panel and is correctly operating the Interlock switch. A distinct audible CLICK may be heard when switch is activated/de-activated. Also check the interlock switch within the Transducer connector.

Wait 10sec for load fault to self-reset depending upon logic state upon power up fault may be reported.

Also:

Check Interlock switch within power cable junction box

Replace Interlock Relay

Replace Relay Board

Replace Control Board

Check ancillary wiring

Unit Resets as Normal, HV Will Not Select

Check position of Remote/Local switch. Also:

Replace Control Board

Replace Front Panel Board

Replace Front Panel Power Selection Switch

HV Relays Operate but no EOC Lamp

Suspect HV Charger or HV BNC charger cable. Also:

Charger Power Switching Relay

Control Board

Output Thyristor

Storage Capacitors

HV Diodes

Auto Power Control Board

EOC Lamp Illuminates, but unit Will Not Discharge

Check for presence of Input Key Pulse and position of Key select switch. Is key Lamp Illuminating in unison with Input Key pulse?, if not suspect Input Key Board. Also:

Control Board

If LED2 on Control Board is Illuminating In Conjunction with Input Key, but unit still not discharging no load fault reported

Check Thyristor Interface board and thyristor.

Check cabling to Thyristor interface board and thyristor.

Upon discharge Load fault reported and unit shuts down

Check load for continuity.

Check load for short circuit, unit will shut down if current greater than 4500A.

EOC and HV Fault Lamp Illuminated

Open circuit on HV Charger output. Also:

*Open Circuit Energy Storage Capacitor
(Verify by trying alternative power setting)*

HV Fault Illuminated, No EOC

HV Charger Faulty, Also:

*Short Circuit Energy Storage Capacitor
(Verify by trying an alternative power setting)*

No Warning Lamps Illuminated, No EOC and No Output

Press Charge Rate switch, if Unit now operates then Auto Charge Control board is faulty.

Unit Fires on Alternative Key Pulses

Input Key Rate too high.

15. Troubleshooting Guide

POWER SELECT SWITCH SHOULD BE LEFT ON 50 JOULES

This section is to be carried out by trained personnel only and undertaken in a safe environment. A transducer or dummy load should be connected to the unit, prior to these tests.

Problem	Possible Fault Condition	Test	Action
Unit fails to discharge with High Voltage and EOC LEDs on.	No Key Input to CSP Unit.	Check connection from key source.	-
-	Key LED flashing & LED 2 on control brd is flashing.	Check connection to / from thyristor Int Brd. Check for presence of TTL trigger pulse with oscilloscope on ZD1 on Thyristor Int Brd.	Repair cabling if required.
-	If all LEDs are correct and load is properly connected, there may be a problem with the thyristor.	Check 5Vdc on Thyristor Int Brd.	Replace thyristor.
High Voltage LED will not light after pressing 'HV ON'.	Remote / local Switch switched to remote, not allowing operator to turn HV on from the unit.	Check Local / Remote Switch.	Change if required.
End Of Charge LED fails to light when unit is firing.	CSP is being fired too quickly.	Slow firing rate and observe EOC LED.	Slow the firing rate until EOC LED is flashing allowing capacitors to reach full charge.
Unit fails to discharge at 50J setting.	Capacitor / Relay problem.	Listen for 100J relay to click in when HV ON button is pressed. Check HV is OK by trying on a different power setting. (200J). If relay clicks in, and unit operates at different power setting, a faulty capacitor could be the problem.	Substitute capacitor.

Before carrying out the following checks, remove AC power to High Voltage Charger by disconnecting the yellow crimp connectors on the large relay located below and to the left side of the Control Board. This will disable the 4kV supply.

POWER SELECT SWITCH SHOULD BE LEFT ON 50 JOULES

This section is to be carried out by trained personnel only and undertaken in a safe environment

Problem	Possible Fault Condition	Test	Action
OFF / ON circuit breaker snaps open on power up.	Mains filter defective.	Check for S/C between live / neutral and ground.	Replace mains filter if required.
-	Mains wiring problem.	Check with ohm meter mains wiring to unit.	Correct if necessary.
Circuit breaker OK, no LEDs on front panel.	Fuse F1 open circuit (O/C).	Check with ohm meter.	Replace.
-	No O/P from 12V PSU.	Remove LHS panel and measure O/P from PSU located to the rear of unit.	Check internal fuse. If faulty, replace. If OK replace board.
-	Problem with control board.	Remove PL1 (12V I/P to board) and measure 12VDC on plug.	If 12VDC is present replace control board.
-	Problem with front panel board.	Check for 12VDC on board.	Replace board.
-	Broken connection(s) between control and front panel boards.	Using DVM set to ohms range, check for continuity of wiring.	Correct if required.
Fault and Interlock LEDs stay lit after reset button pressed.	Top cover microswitch not closed.	Replace lid and screw in place.	Re-check after lid is replaced.
-	High voltage connector not fully mated.	-	Check / Re-seat.
-	Lid of junction box (if being used) not in place.	Close lid.	Re-check.
-	Also no front panel fans operating.	Check fuses F1 and F2 with ohm meter.	-
-	Relay PSU board U/S.	Remove LHS panel. Measure 240VAC with meter on Pins 1 & 2 of PL1. Measure 12VDC on PL1 Pins 8 (+ve) and 9 (-ve).	Replace if DC voltage is not present.

Problem	Possible Fault Condition	Test	Action
When HV ON button is pressed HV LED comes on (after approximately 3 seconds) but HV relay(s) do not operate.	Fuse F2 blown.	Check with ohm meter.	Replace.
-	Control board faulty.	-	Replace.
-	High voltage relay faulty.	Switch power select SW on front panel to 200J.	If this relay operates, relay A may be faulty. Check wiring from control board. If wiring OK a new relay may be required.

16. Changing a Thyristor 'Module' in the Field



SAFETY NOTICE

Ensure all mains voltages are switched off and disconnected from the unit before attempting any maintenance or upgrades.

Only trained engineers or qualified technicians should attempt any maintenance or upgrades.

CAUTION: HV capacitors may contain some residual charge.

Tools

Flat Blade Screw Driver.
10mm Ring Spanner x 2.

Procedure

- (A) Remove the connections to the HV Buzz Bars using the 10mm ring spanners. Noting the wiring configuration.
- (B) Remove the interface control cabling.
- (C) Remove the upper clamp plate by removing the two M5 securing screws.
- (D) The Thyristor Module can now be removed from the clamp.
- (E) The Buzz Bars are interchangeable between modules.
- (F) Fitting is the reverse of this procedure.

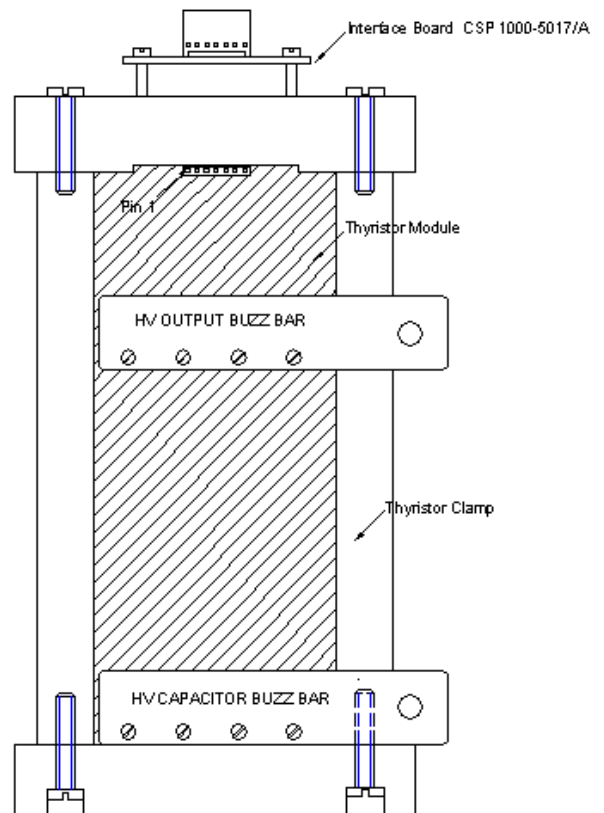

SECTION 3 – CIRCUIT AND BLOCK DIAGRAMS

Introduction

Section 3 contains schematics only. For circuit descriptions refer to Section 2.

Circuit and Block Diagrams Index

	Drawing No/Rev	Description	Page
1	CSP-1000-5000/2	CSP Control Brd Schematic 1 of 2	42
2	CSP-1000-5000/2	CSP Control Brd Schematic 2 of 2	43
3	CSP-1000-5002/1	CSP Relay Brd Schematic	44
4	CSP-CSPD-5109/2	CSP Key In Brd Schematic	45
5	CSP-1000-5005/2	CSP AVIP Brd Schematic	46
6	-	-	-
7	CSP-CSPD-5100/2	CSPD Front Panel Brd Schematic	47
8	CSP-CSPD-5101/3	CSPD HV Detect Brd Schematic	48
9	CSP-CSPD-5102/5	CSPD HV Monitor Brd Schematic	49
10	CSP-CSPD-4021/3	CSPD Control Wiring	50
11	CSP-CSPP-4012/A	CSPP HV Wiring	51
12	CSP-CSPP-1000/2	CSPP LHS Component Location	52
13	CSP-CSPP-1001/1	CSPP Base Tray Component Location	53
14	-	-	-
15	-	-	-
16	CSP-CSPD-1011/1	CSP High Voltage Plug Assembly	54
17	CSP-CSPD-1012/1	CSP High Voltage Plug Component Assy	55
18	CSP-CSPD-3002/1	CSP Junction Box HV Cable	56
19	CSP-CSPD-4024/1	Remote Cable Wiring	57

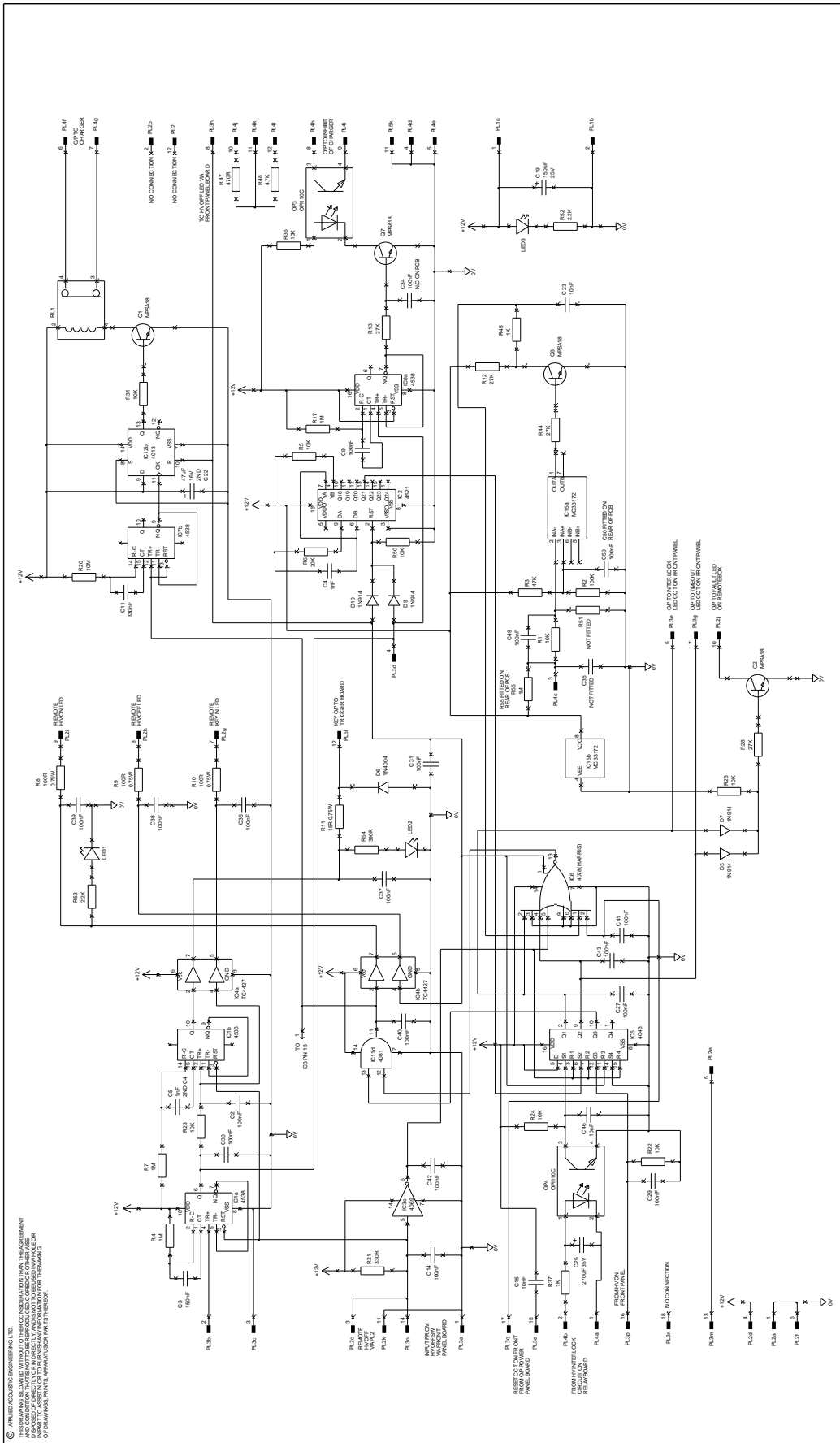

APPLIED ACOUSTIC ENGINEERING LTD.
 THE INFORMATION CONTAINED HEREIN IS THE PROPERTY OF APPLIED ACOUSTIC ENGINEERING LTD. AND IS NOT TO BE REPRODUCED OR TRANSMITTED IN ANY FORM OR BY ANY MEANS, ELECTRONIC OR MECHANICAL, INCLUDING PHOTOCOPYING, RECORDING, OR BY ANY INFORMATION STORAGE AND RETRIEVAL SYSTEM. THE INFORMATION CONTAINED HEREIN IS THE PROPERTY OF APPLIED ACOUSTIC ENGINEERING LTD. AND IS NOT TO BE REPRODUCED OR TRANSMITTED IN ANY FORM OR BY ANY MEANS, ELECTRONIC OR MECHANICAL, INCLUDING PHOTOCOPYING, RECORDING, OR BY ANY INFORMATION STORAGE AND RETRIEVAL SYSTEM.

ISSUE	DESCRIPTION	APPD.	DATE	ALL DIMS IN mm	NOT TO SCALE	APPLIED ACOUSTIC ENGINEERING LTD.	DRAWN	CD	DATE	TITLE	
2	DCR 1174	NM	07/12			CSP1000 CONTROL BOARD SCHEMATIC SHEET 1 OF 2	CHECKED	RJW	20/07/12		
1	DCR 302 - CS VALUE CHANGE	APD	3/07				APPROVED	NM			
C	REDRAWING ERRORS	APD	5/02								DRAWING No. CSP-1000-5000/2

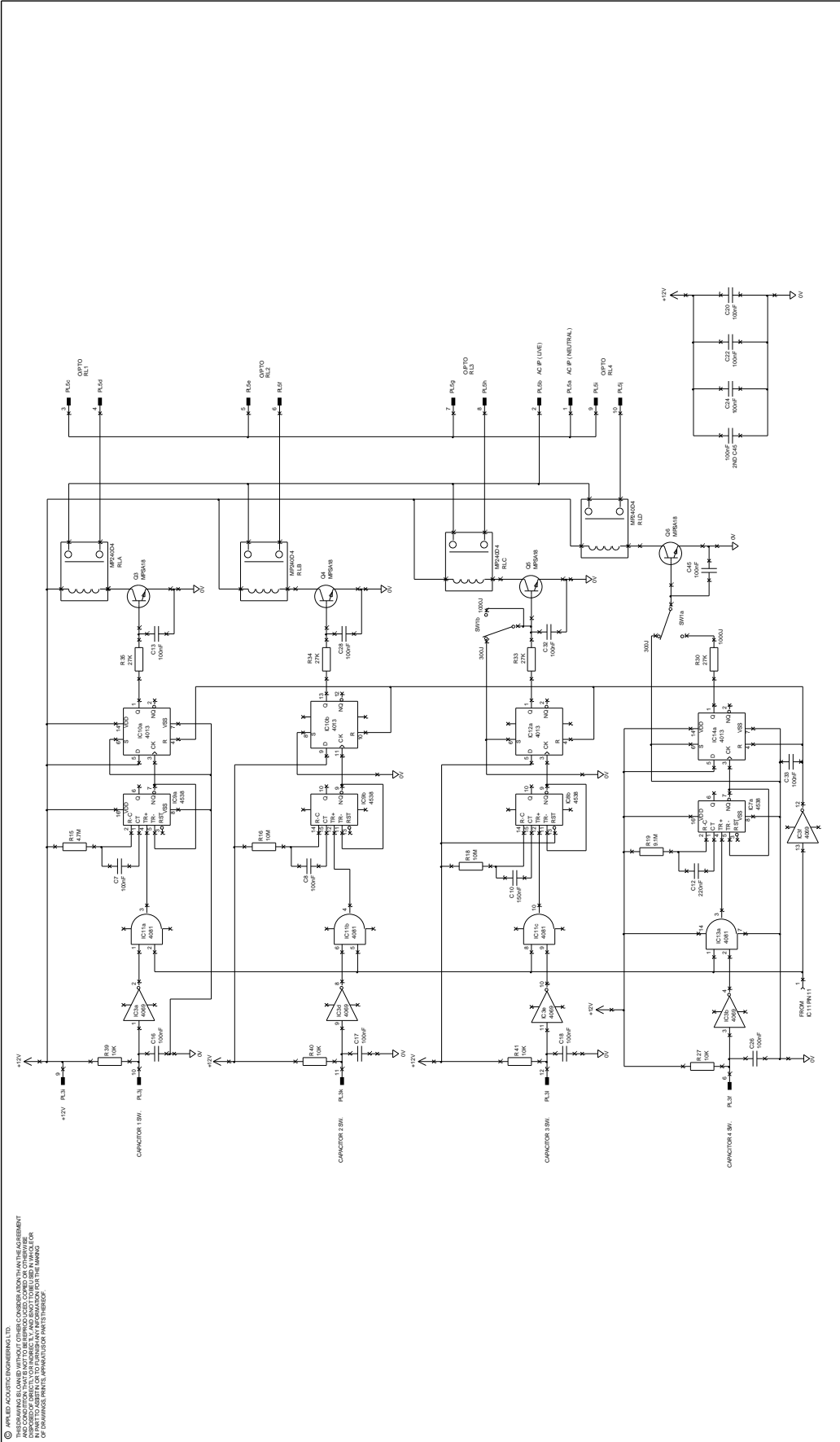

TITLE	DATE	DRAWN	DATE	APPLIED ACUSTIC ENGINEERING LTD.	NOT TO SCALE	ALL DIMS IN (mm)	DATE	APPROVED	DRAWING No.
	CSP-1000 CONTROL BOARD CIRCUIT DIAGRAM SHEET 2 OF 2		DATE				CSP-1000-5000/2		
CD	DATE	CHECKED	DATE	APPROVED	FROM	MATERIAL	DATE	APPROVED	DRAWING No.
	R.J.W.		DATE				CSP-1000-5000/2		
NM	DATE	APPROVED	DATE	APPROVED	FILE NAME	CSP-100-5000-2 Control Board Schematic-Sheet 2	DATE	APPROVED	DRAWING No.
	N.M.		DATE				CSP-1000-5000/2		

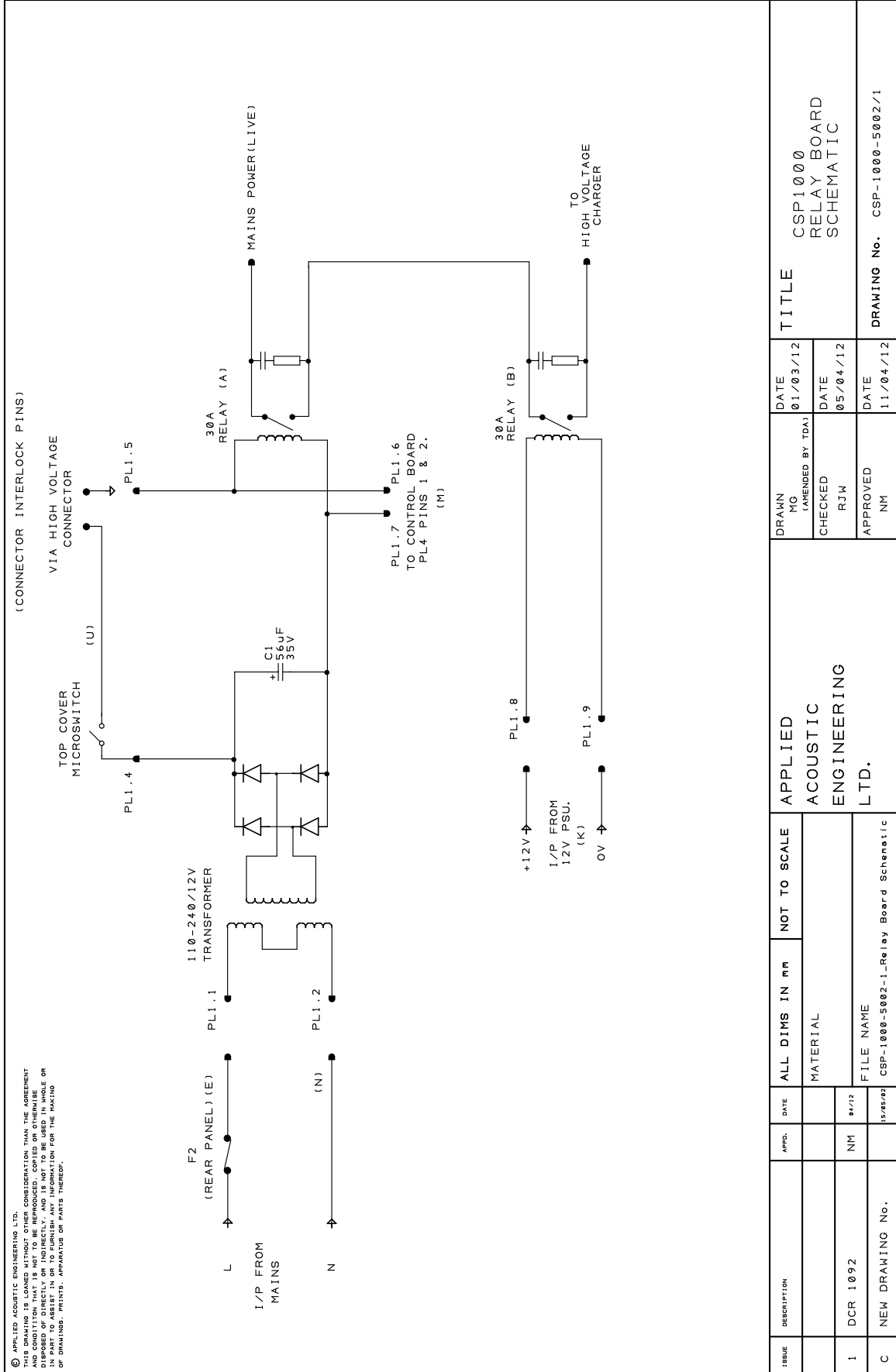

ISSUE	DESCRIPTION	APPRD.	DATE	ALL DIMS IN mm	NOT TO SCALE	APPLIED ACOUSTIC ENGINEERING LTD.	DRAWN MG (AMENDED BY TDA)	DATE	TITLE
1	DCR 1092	NM	04/12	MATERIAL			CHECKED RJW	05/04/12	CSP1000 RELAY BOARD SCHEMATIC
C	NEW DRAWING No.		15/05/02	FILE NAME CSP-1000-5002-1-Relay Board Schematic			APPROVED NM	11/04/12	DRAWING No. CSP-1000-5002/1

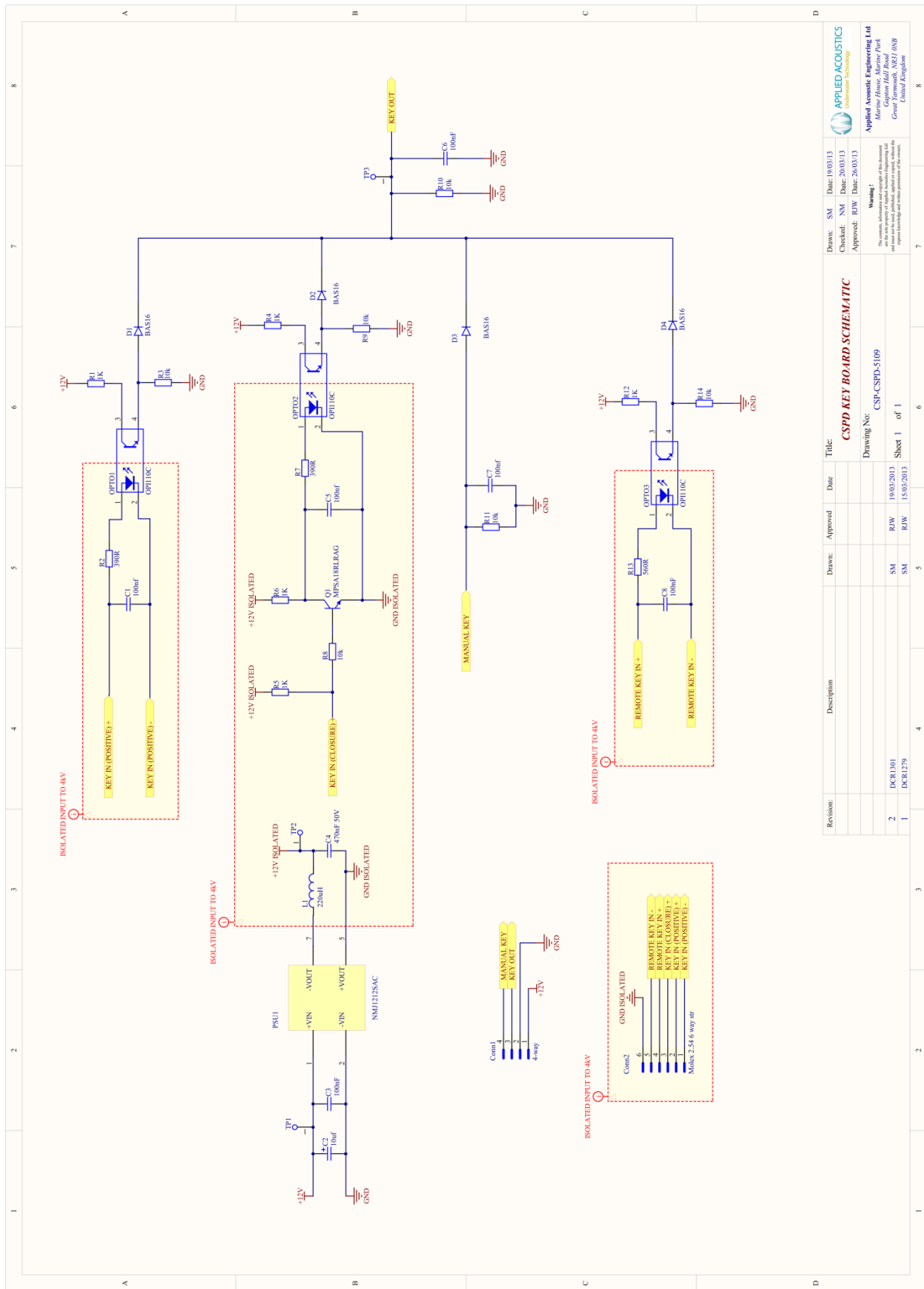

Revision:	Description	Drawn:	Approved:	Date	Title:
2	DCR1301	SM	RJW	19/03/2013	CSPD KEY BOARD SCHEMATIC Drawing No: CSP-CSPD-5109
1	DCR1279	SM	RJW	15/03/2013	

Drawn:	SM	Date:	19/03/13
Checked:	NM	Date:	20/03/13
Approved:	RJW	Date:	26/03/13

Warning:
 The contents, information and copyright of this document and any associated drawings, published or otherwise, shall remain the property of Applied Acoustics and any reproduction or translation without the express written permission of the company is prohibited.

Applied Acoustics Engineering Ltd
 Marine House, Marine Park
 Great Yarmouth, NR21 0JF
 United Kingdom

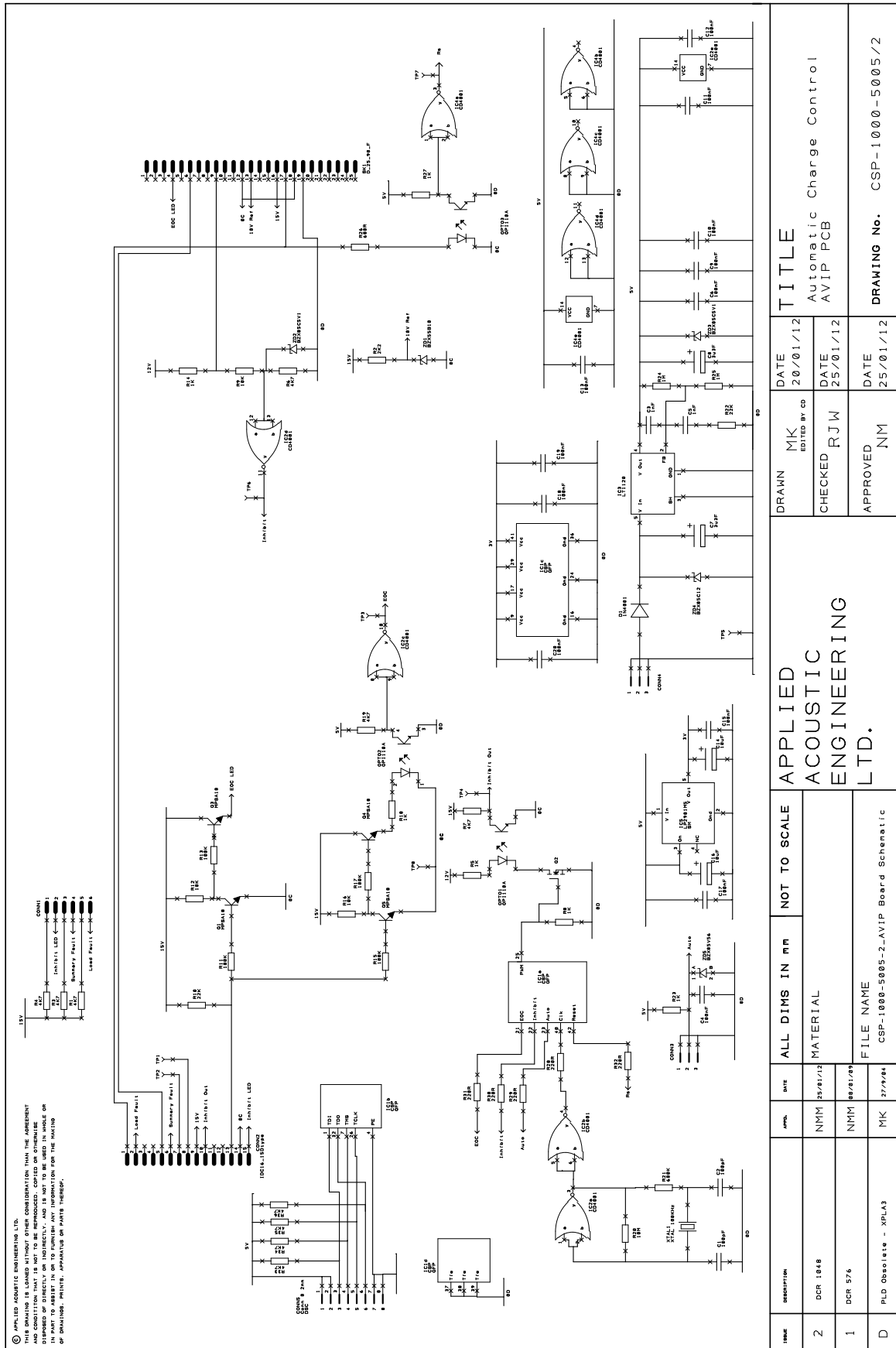

© APPLIED ACOUSTIC ENGINEERING LTD.
 THIS DRAWING IS LOANED WITHOUT OTHER CONSIDERATION THAN THE AGREEMENT
 DISPOSED OF DIRECTLY OR INDIRECTLY, AND IS NOT TO BE USED IN WHOLE OR
 IN PART TO ASSIST IN OR TO FURNISH ANY INFORMATION FOR THE MAKING
 OF DIMENSIONS, PRINTS, APPARATUS OR PARTS THEREOF.

NO.	DESCRIPTION	DATE	ALL DIMS IN mm	NOT TO SCALE	APPLIED ACOUSTIC ENGINEERING LTD.	DRAWN	MK	DATE	TITLE
2	DCR 1848	NMM	25/01/12	MATERIAL	CSP-1000-5005-2-AVIP Board Schematic	CHECKED	RJW	25/01/12	Automatic Charge Control AVIP PCB
1	DCR 576	NMM	08/01/09	FILE NAME		APPROVED	NM	25/01/12	
D	PLD Obsolete - XPLA3	MK	27/7/04						DRAWING No. CSP-1000-5005/2

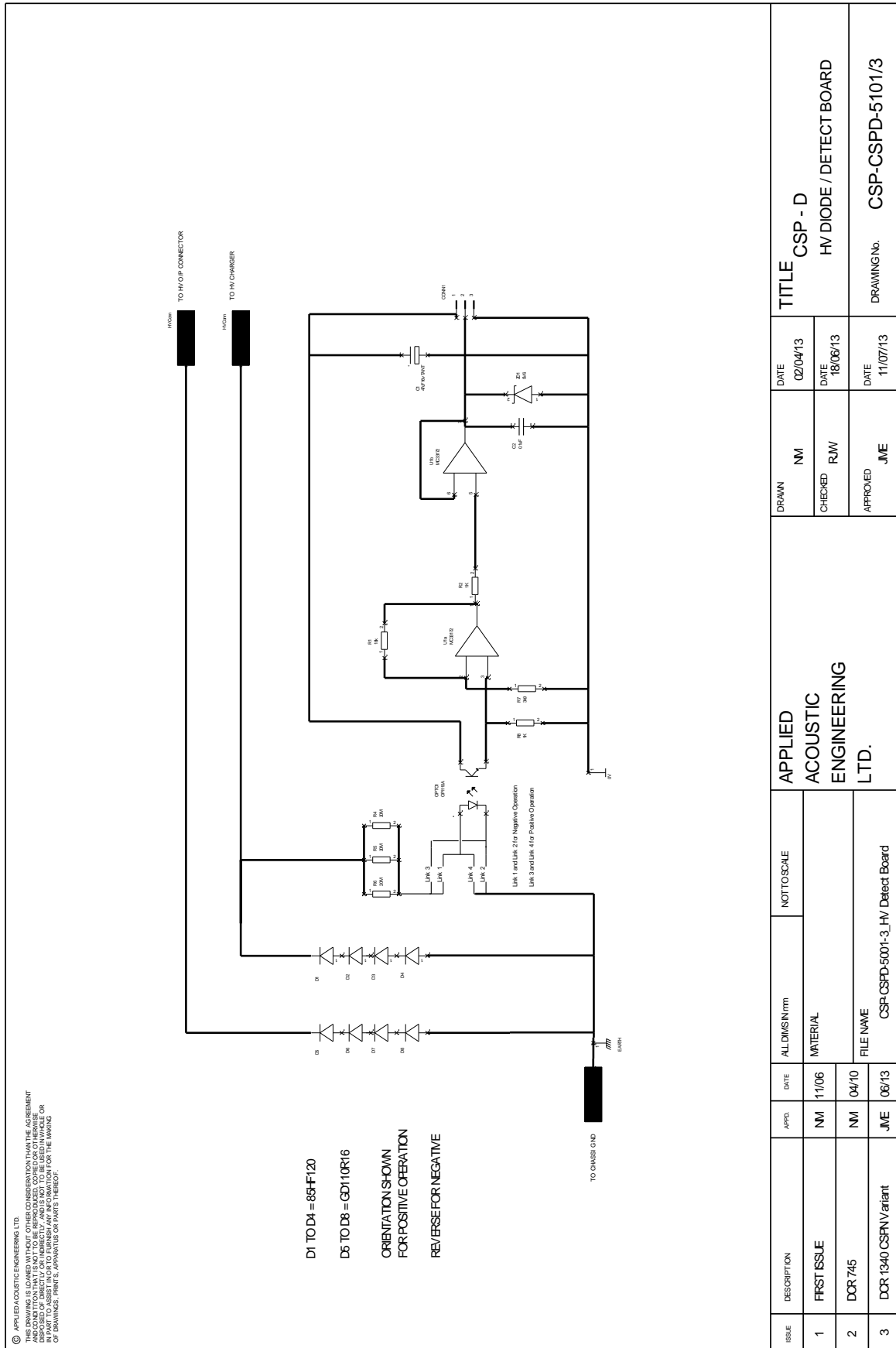

ISSUE	DESCRIPTION	APPROVED	DATE	ALL DIMS IN (mm)	NOT TO SCALE	APPLIED ACUSTIC ENGINEERING LTD.		DRAWN	DATE	TITLE
1	FRST ISSUE	NM	11/06	MATERIAL				NM	02/04/13	CSP - D
2	DCR 745	NM	04/10					R/W	18/06/13	HV DIODE / DETECT BOARD
3	DCR 1340 CSPNP variant	JME	06/13	FILE NAME CSP-CSPD-5001-3_HV Detect Board				JME	11/07/13	DRAWING No. CSP-CSPD-5101/3

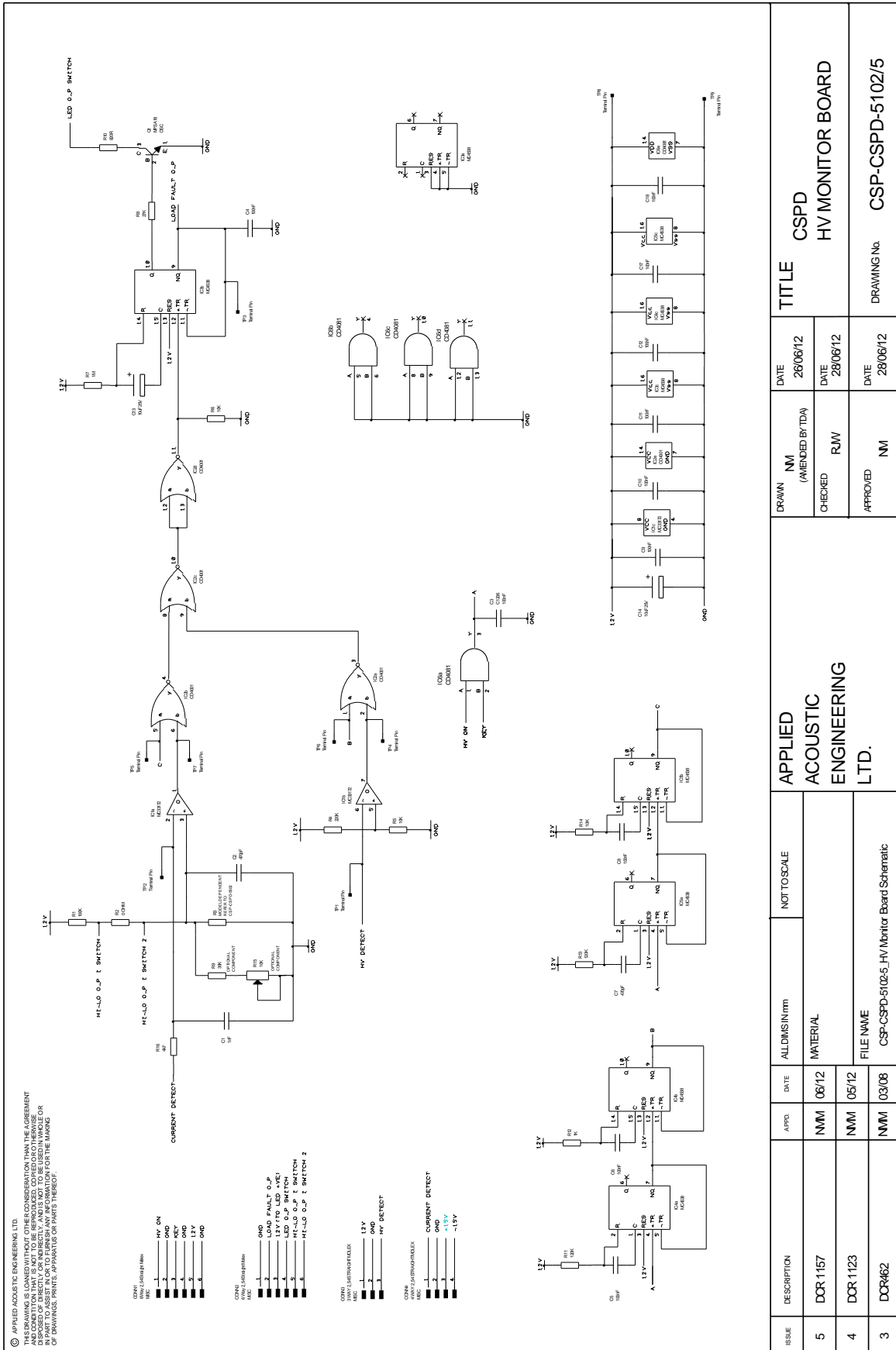

ISSUE	DESCRIPTION	APPROVED	DATE	ALL DIMS IN (mm)	NOT TO SCALE	APPLIED ACOUSTIC ENGINEERING LTD.	DRAWN NM (AMENDED BY DA)	DATE 26/06/12	TITLE CSPD HV MONITOR BOARD
5	DCR 1157	NMM	06/12	MATERIAL			CHECKED RJW	DATE 28/06/12	
4	DCR 1123	NMM	05/12	FILE NAME			APPROVED NM	DATE 28/06/12	
3	DCR462	NMM	03/08	CSP-CSPD-5102-5 HV Monitor Board Schematic					DRAWING No. CSP-CSPD-5102/5

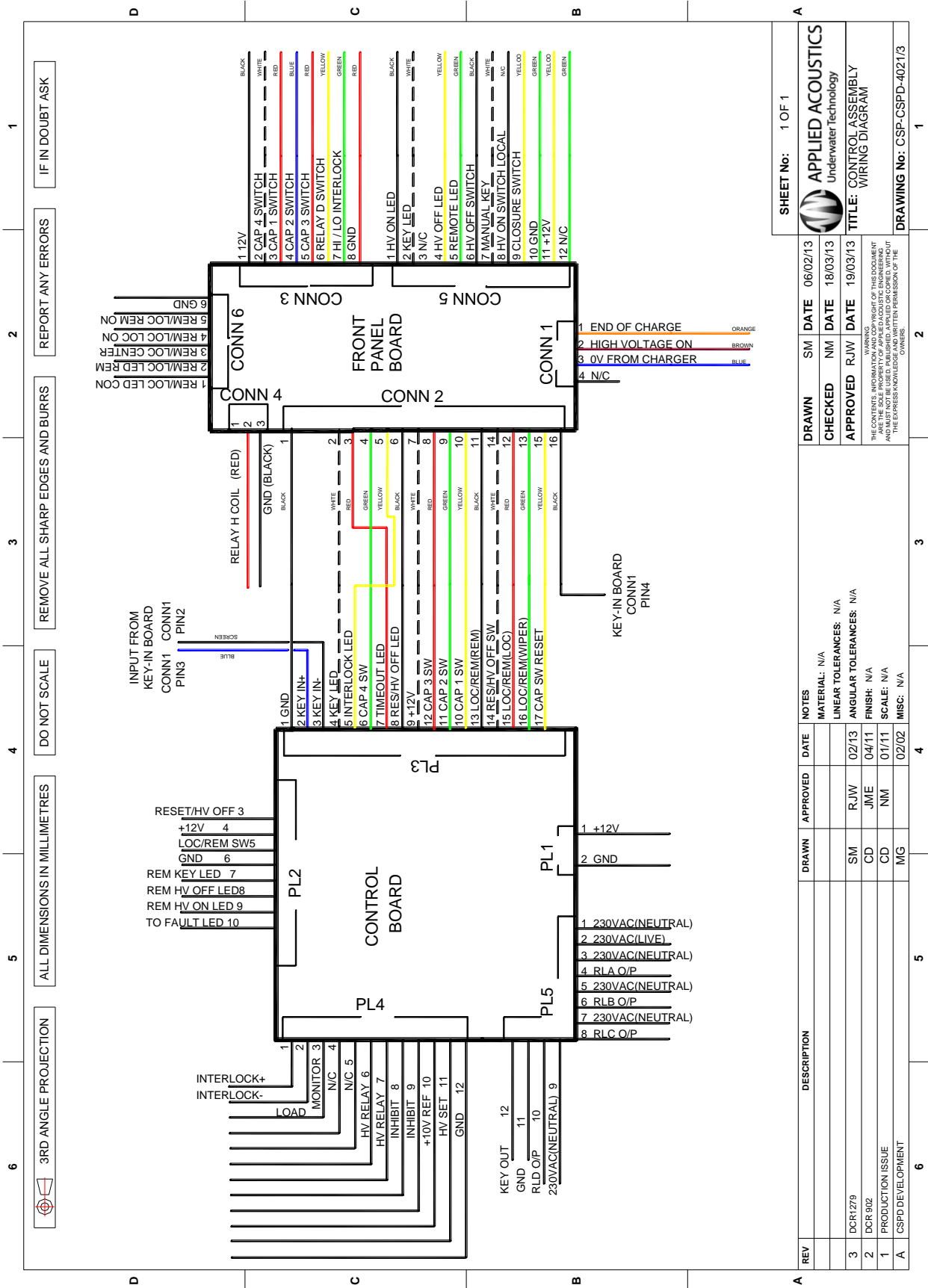

REV	DESCRIPTION	DRAWN	APPROVED	DATE	NOTES
3	DCR1279	SM	RJW	02/13	
2	DCR 902	CD	JME	04/11	
1	PRODUCTION ISSUE	CD	NM	01/11	
A	CSPD DEVELOPMENT	MG	MG	02/02	

DRAWN	SM	DATE	06/02/13
CHECKED	NM <td>DATE</td> <td>18/03/13</td>	DATE	18/03/13
APPROVED	RJW <td>DATE</td> <td>19/03/13</td>	DATE	19/03/13

APPLIED ACOUSTICS
Underwater Technology

TITLE: CONTROL ASSEMBLY WIRING DIAGRAM

DRAWING No: CSP-CSPD-4021/3

3RD ANGLE PROJECTION

ALL DIMENSIONS IN MILLIMETRES

DO NOT SCALE

REMOVE ALL SHARP EDGES AND BURRS

REPORT ANY ERRORS

IF IN DOUBT ASK

SHEET No: 1 OF 1

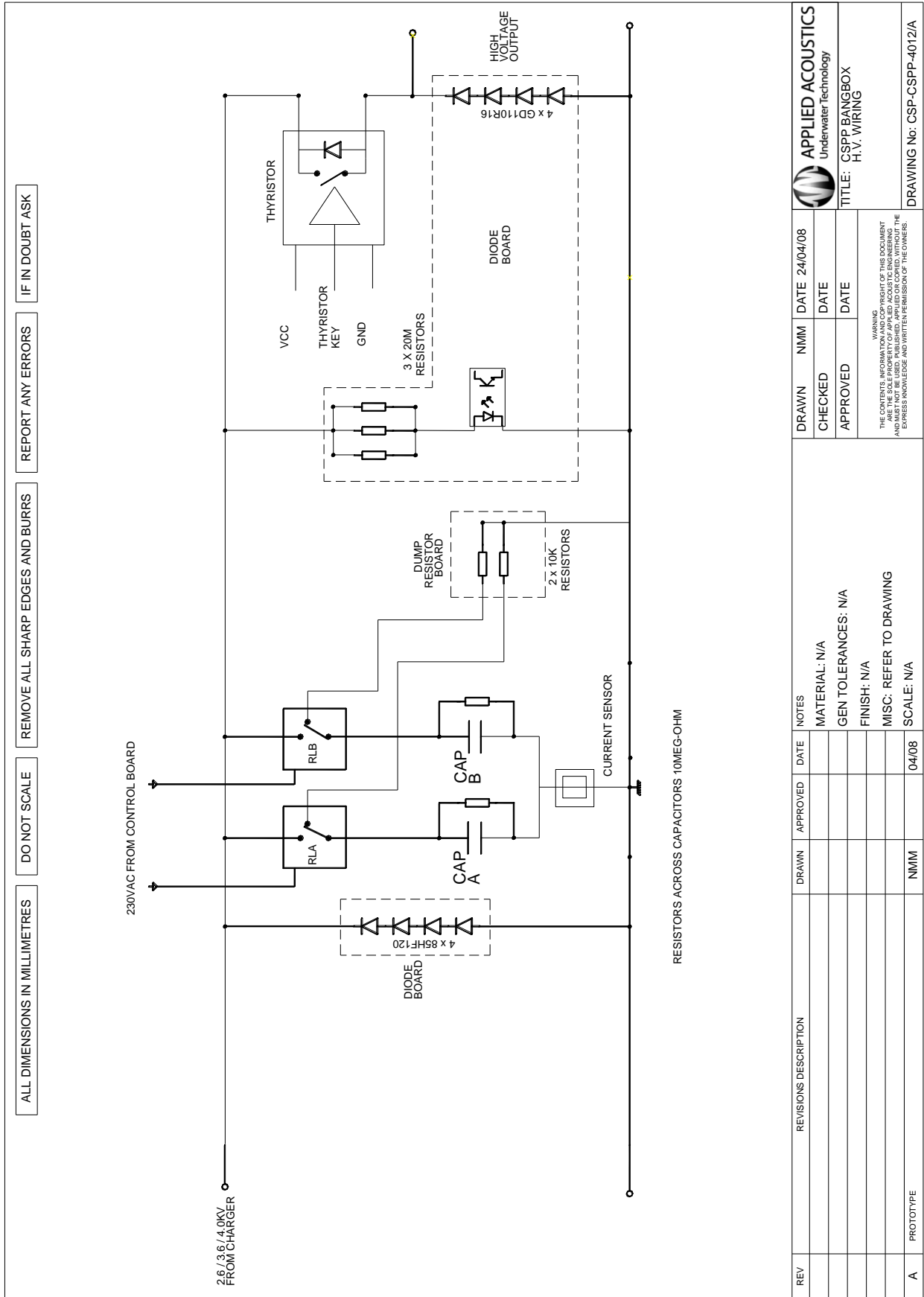

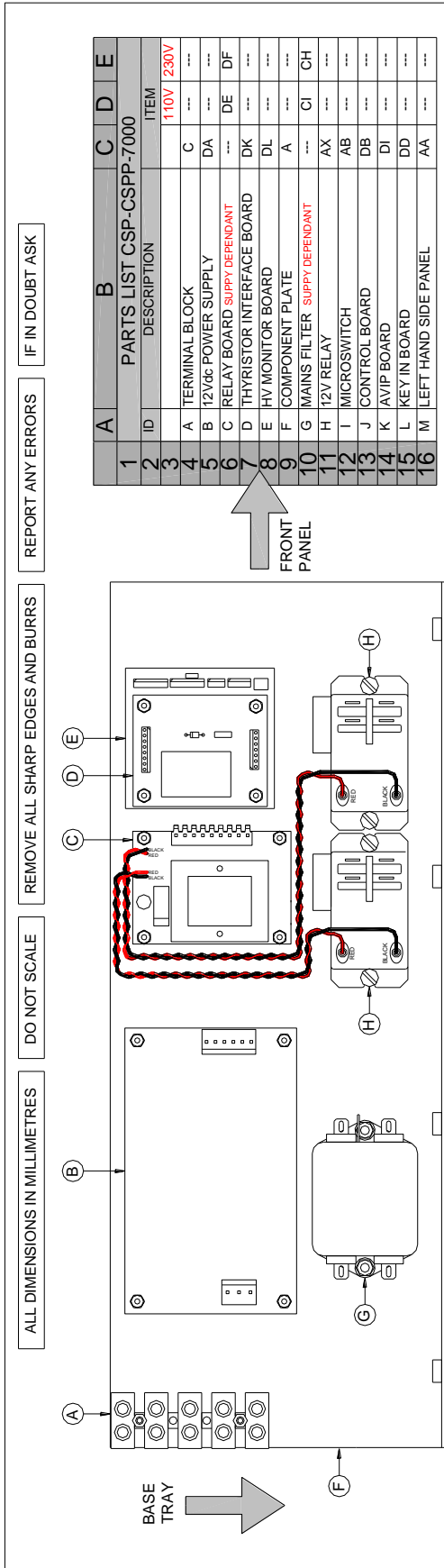

FIG. 1 COMPONENT PLATE

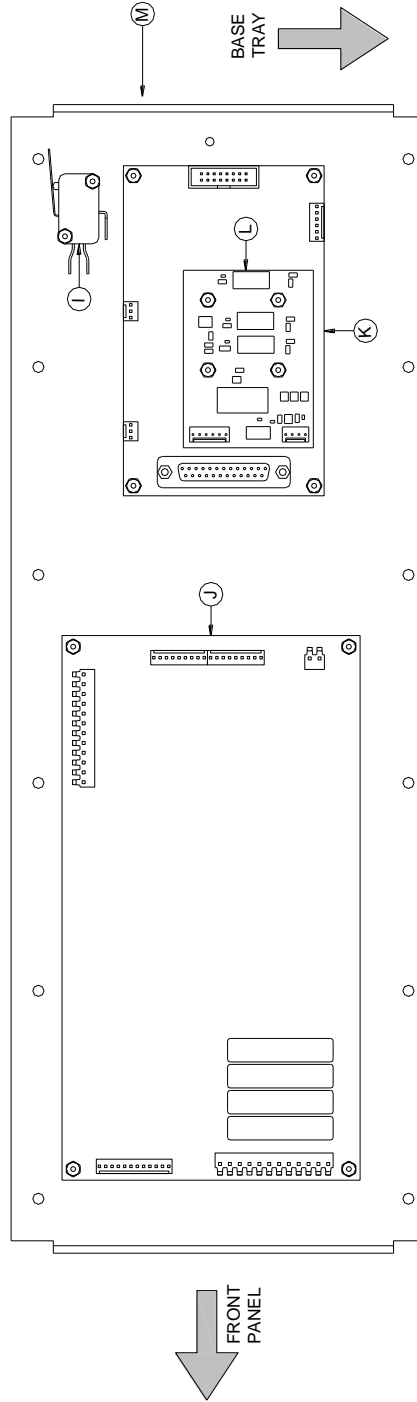

FIG. 2 LEFT HAND SIDE PANEL

POSITION OF PANELS INSIDE CSP ARE SHOWN IN CSP-CSPNP-1001

REV	REVISIONS DESCRIPTION	DRAWN	APPROVED	DATE	NOTES
2	DCR1279	SM	RJW	03/13	MATERIAL: REFER TO DRAWING
1	PRODUCTION ISSUE AND DCR 770	CD	NM	06/10	GEN TOLERANCES: N/A
B	CONTROL, RELAY & AUTO CHARGE CONTROL PCB'S ORIENTATION ROTATED BY 180°	TDA		08/08	FINISH: N/A
A	PROTOTYPE	NMM		06/08	MISC: REFER TO DRAWING
					SCALE: N/A

DRAWN	SM	DATE	19/03/13
CHECKED	NM <td>DATE</td> <td>19/03/13</td>	DATE	19/03/13
APPROVED	RJW <td>DATE</td> <td>19/03/13</td>	DATE	19/03/13

APPLIED ACOUSTICS	
Underwater Technology	
TITLE:	CSPNP BANGBOX LEFT HAND SIDE PANEL COMPONENT LOCATION (GENERAL ASSEMBLY)

DRAWING No. CSP-CSPNP-1000/2	
------------------------------	--

WARNING: THE CONTENTS, INFORMATION AND COPYRIGHT OF THIS DOCUMENT ARE THE PROPERTY OF APPLIED ACOUSTICS. IT IS TO BE USED AND MUST NOT BE REPRODUCED, PUBLISHED, APPLIED FOR, OR IN ANY MANNER EXPRESS OR IMPLIED, WITHOUT THE EXPRESS KNOWLEDGE AND WRITTEN PERMISSION OF THE OWNERS.

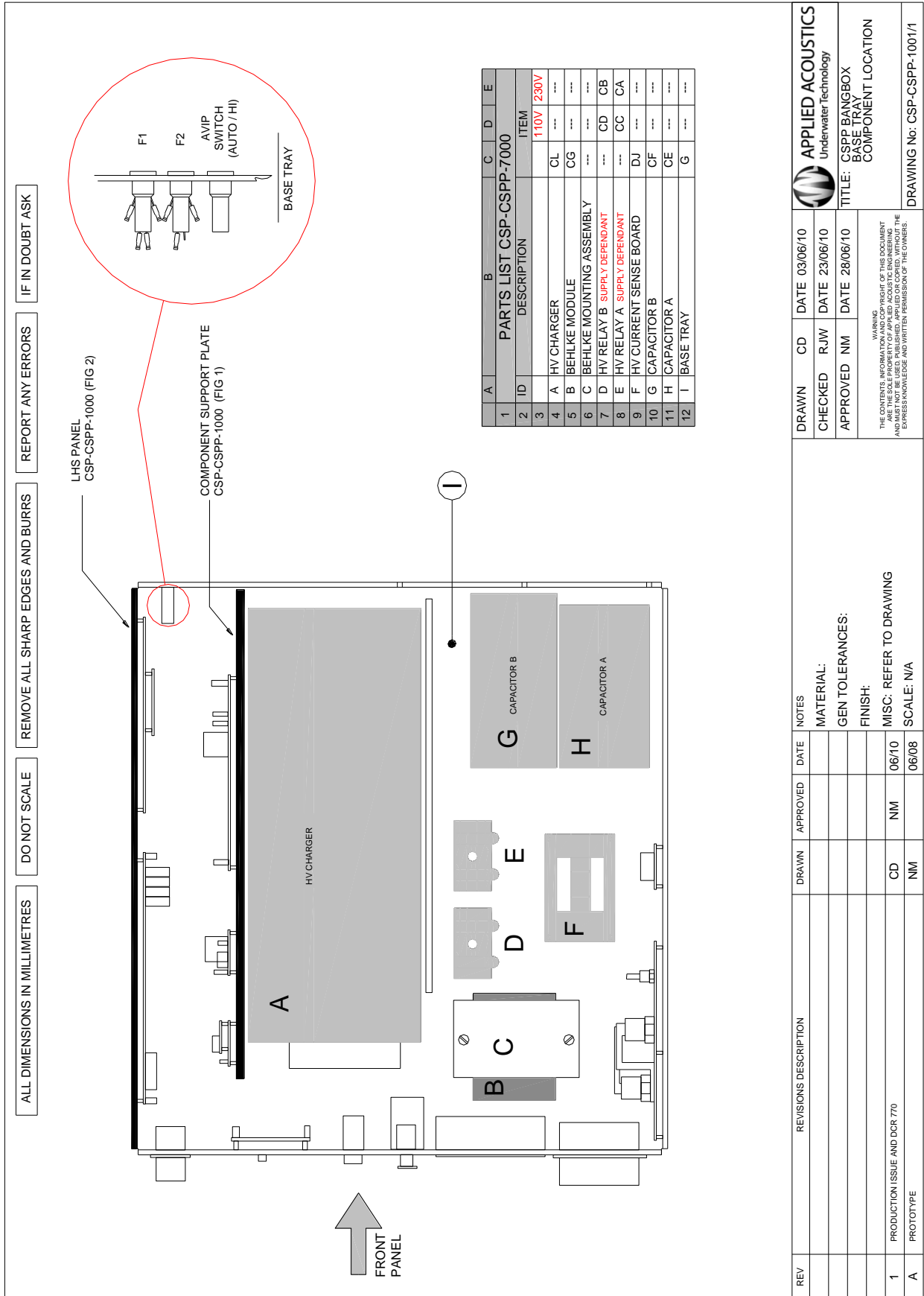

A	B	C	D	E
1	PARTS LIST CSP-CSPNP-7000			
2	ID	DESCRIPTION	ITEM	
3			110V / 230V	
4	A	HV CHARGER	CL	***
5	B	BEHLKE MODULE	CG	***
6	C	BEHLKE MOUNTING ASSEMBLY	***	***
7	D	HV RELAY B SUPPLY DEPENDANT	CD	CB
8	E	HV RELAY A SUPPLY DEPENDANT	***	CC CA
9	F	HV CURRENT SENSE BOARD	DJ	***
10	G	CAPACITOR B	CF	***
11	H	CAPACITOR A	CE	***
12	I	BASE TRAY	G	***

REV	REVISIONS DESCRIPTION	DRAWN	APPROVED	DATE	NOTES
1	PRODUCTION ISSUE AND DCR 770	CD	NM	06/10	
A	PROTOTYPE	NM		06/08	

DRAWN	CD	DATE	03/06/10
CHECKED	RJW	DATE	23/06/10
APPROVED	NM	DATE	28/06/10

APPLIED ACOUSTICS
 Underwater Technology

TITLE: CSPNP BANGBOX
 BASE TRAY
 COMPONENT LOCATION

WARNING
 THE CONTENTS, INFORMATION AND COPYRIGHT OF THIS DOCUMENT
 AND MUST NOT BE USED, PUBLISHED, APPLIED OR COPIED, WITHOUT THE
 EXPRESS KNOWLEDGE AND WRITTEN PERMISSION OF THE OWNERS.

DRAWING No: CSP-CSPNP-1001/1

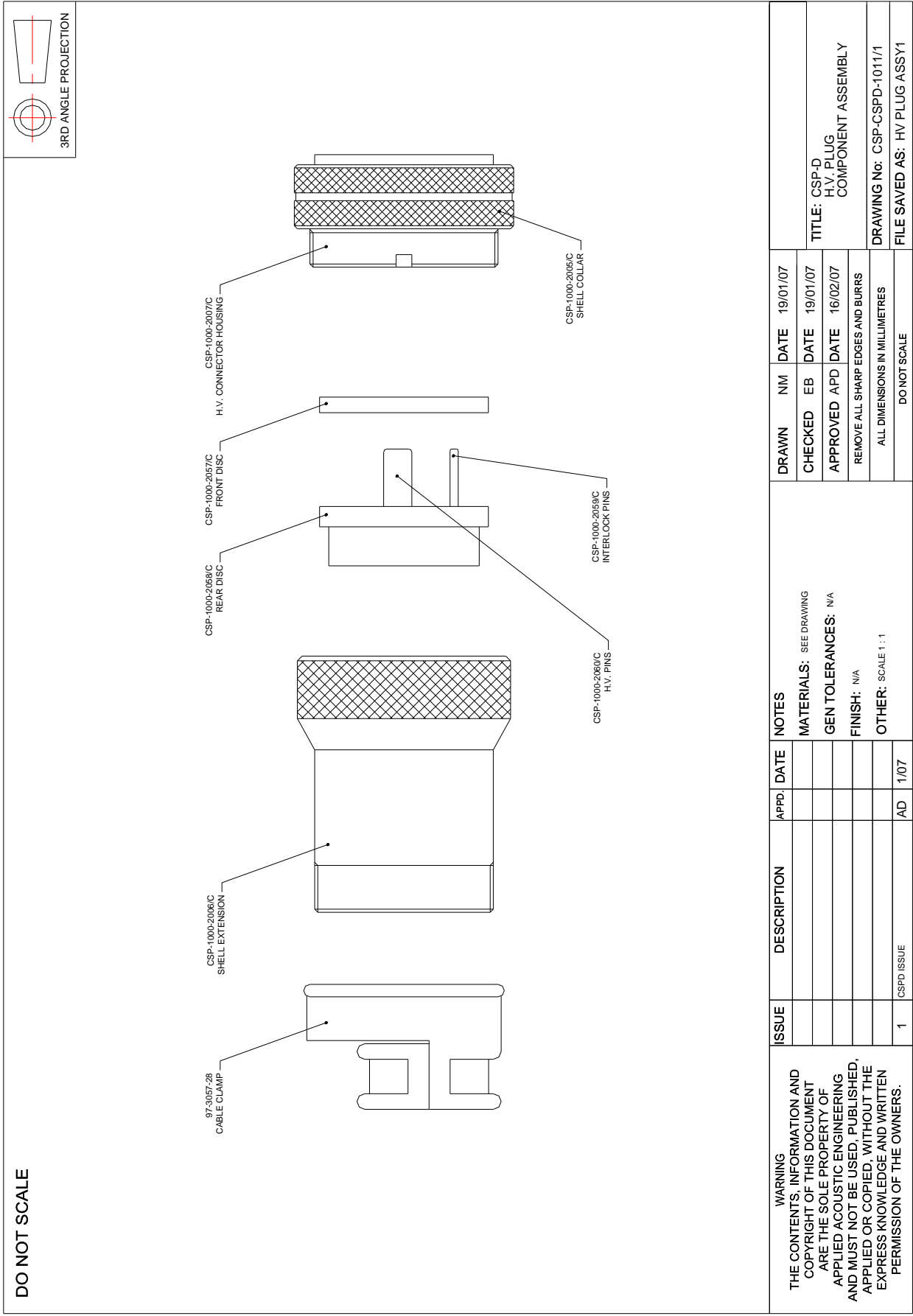

WARNING THE CONTENTS, INFORMATION AND COPYRIGHT OF THIS DOCUMENT ARE THE SOLE PROPERTY OF APPLIED ACOUSTIC ENGINEERING AND MUST NOT BE USED, PUBLISHED, APPLIED OR COPIED, WITHOUT THE EXPRESS KNOWLEDGE AND WRITTEN PERMISSION OF THE OWNERS.	ISSUE	DESCRIPTION	APPD	DATE	NOTES	DRAWN	NM	DATE
	1	CSPD ISSUE	AD	1/07				19/01/07
					MATERIALS: SEE DRAWING	CHECKED	EB	DATE
					GEN TOLERANCES: N/A	19/01/07		19/01/07
				FINISH: N/A	APPROVED	APD	DATE	16/02/07
				OTHER: SCALE 1 : 1	REMOVE ALL SHARP EDGES AND BURRS			
					ALL DIMENSIONS IN MILLIMETRES			
					DO NOT SCALE			
					DRAWING No: CSP-CSPD-1011/1			
					FILE SAVED AS: HV PLUG ASSY1			
					TITLE: CSP-D HV PLUG COMPONENT ASSEMBLY			

<p>DO NOT SCALE</p> <p>1. CLEAN AND DEGREASE THE HV PINS CSP-1000-2060/C. STRIP 12mm OF INSULATION FROM THE ENDS OF 2, 1500mm LENGTHS OF H.V. CABLE. SOLDER THE HV PINS ONTO THE CABLE (THE SOLDERING IRON SHOULD BE 100W OR MORE). CHECK FOR GOOD CONNECTION BEFORE CLEANING AND DEGREASING. APPLY HEATSHRINK AS SHOWN, RED ON ONE PIN, BLACK ON THE OTHER, USE A 50mm LENGTH OF HEATSHRINK AND COVER UP TO THE RETAINING RING GROOVE.</p>	<p>PIN POLARITY REAR VIEW</p> <p>3RD ANGLE PROJECTION</p> <p>3. FIT THE RETAINING RINGS (CSP-1000-2053/C) ON THE H.V. PINS. PUSH THE H.V. PINS BACK INTO THE RECESSES IN THE REAR DISC ENSURING CORRECT POLARITY.</p>	<p>2. TAKE 2100mm OF TWIN SCREENED CABLE (FEC 140-643) STRIP 50mm OF THE OVERALL GREY INSULATION FROM ONE END AND REMOVE THE SCREEN. STRIP 5mm OF INSULATION FROM THE RED AND THE BLUE INNER CORES. FEED THE 2 WIRES THROUGH THE SMALL HOLES IN THE PTFE REAR DISC CSP-1000-2058/C AND SOLDER THE INTERLOCK PINS TO THE WIRES. CLEAN AND DEGREASE THE PINS AND PUSH THEM INTO THE RECESS IN THE REAR DISC. THE PINS ARE NOT POLARITY SENSITIVE.</p>	<p>4. PUSH THE PTFE FRONT DISC (CSP-1000-2057/C) OVER THE ASSEMBLY AS SHOWN. REFER TO DRAWING CSP-1000-3005/C AND ASSEMBLE THE CONNECTOR AS FOLLOWS:</p> <ol style="list-style-type: none"> PUSH THE 2 PTFE DISCS INTO THE HOUSING FEED THE LOCKING COLLAR OVER THE HOUSING SO THAT IT ROTATES FREELY SECURE THE PTFE INSERTS INTO THE HOUSING USING CIRCLIP (NIFCSB-055) SCREW THE EXTENSION SHELL ONTO THE HOUSING SCREW THE CABLE CLAMP ONTO THE EXTENSION SHELL AND SECURE THE CABLE WITH THE CABLE CLAMP. <p>5. USING AN 8KV MEGGER PERFORM THE FOLLOWING INSULATION TESTS:</p> <ol style="list-style-type: none"> POSITIVE AND NEGATIVE HIGH VOLTAGE PINS POSITIVE HIGH VOLTAGE PIN TO CASE NEGATIVE HIGH VOLTAGE PIN TO CASE POSITIVE HIGH VOLTAGE PIN TO BOTH INTERLOCK PINS NEGATIVE HIGH VOLTAGE PIN TO BOTH INTERLOCK PINS <p>NOTE: BECAUSE OF THE HIGH VOLTAGE INVOLVED, ONLY EXPERIENCED PERSONNEL MUST CARRY OUT THE ABOVE TEST. EXERCISE EXTREME CAUTION, KEEPING CLEAR FROM THE ASSEMBLY WHEN TESTING.</p> <p>6. SEE DRAWING CSP-1000-3004/C FOR DETAILS OF JUNCTION BOX END OF THE CABLE.</p>	<p>WARNING THE CONTENTS, INFORMATION AND COPYRIGHT OF THIS DOCUMENT ARE THE SOLE PROPERTY OF APPLIED ACOUSTIC ENGINEERING AND MUST NOT BE USED, PUBLISHED, APPLIED OR COPIED, WITHOUT THE EXPRESS KNOWLEDGE AND WRITTEN PERMISSION OF THE OWNERS.</p> <table border="1"> <thead> <tr> <th>ISSUE</th> <th>DESCRIPTION</th> <th>APPD.</th> <th>DATE</th> <th>NOTES</th> </tr> </thead> <tbody> <tr> <td>1</td> <td>CSPD ISSUE</td> <td>AD</td> <td>01/07</td> <td></td> </tr> </tbody> </table> <p>MATERIALS: SEE DRAWINGS GEN TOLERANCES: ±2mm FINISH: N/A OTHER: SCALE 1:2</p>	ISSUE	DESCRIPTION	APPD.	DATE	NOTES	1	CSPD ISSUE	AD	01/07		<table border="1"> <thead> <tr> <th>DRAWN</th> <th>NM</th> <th>DATE</th> <th>19/01/07</th> </tr> </thead> <tbody> <tr> <td>CHECKED</td> <td>EB</td> <td>DATE</td> <td>19/01/07</td> </tr> <tr> <td>APPROVED</td> <td>APD</td> <td>DATE</td> <td>16/02/07</td> </tr> <tr> <td colspan="4">REMOVE ALL SHARP EDGES AND BURRS</td> </tr> <tr> <td colspan="4">ALL DIMENSIONS IN MILLIMETRES</td> </tr> <tr> <td colspan="4">DO NOT SCALE</td> </tr> </tbody> </table> <p>TITLE: CSP-D HIGH VOLTAGE PLUG ASSEMBLY DRAWING No: CSP-CSPD-1012/1 FILE SAVED AS: HV PLUG ASSY2.DWG</p>	DRAWN	NM	DATE	19/01/07	CHECKED	EB	DATE	19/01/07	APPROVED	APD	DATE	16/02/07	REMOVE ALL SHARP EDGES AND BURRS				ALL DIMENSIONS IN MILLIMETRES				DO NOT SCALE			
ISSUE	DESCRIPTION	APPD.	DATE	NOTES																																			
1	CSPD ISSUE	AD	01/07																																				
DRAWN	NM	DATE	19/01/07																																				
CHECKED	EB	DATE	19/01/07																																				
APPROVED	APD	DATE	16/02/07																																				
REMOVE ALL SHARP EDGES AND BURRS																																							
ALL DIMENSIONS IN MILLIMETRES																																							
DO NOT SCALE																																							

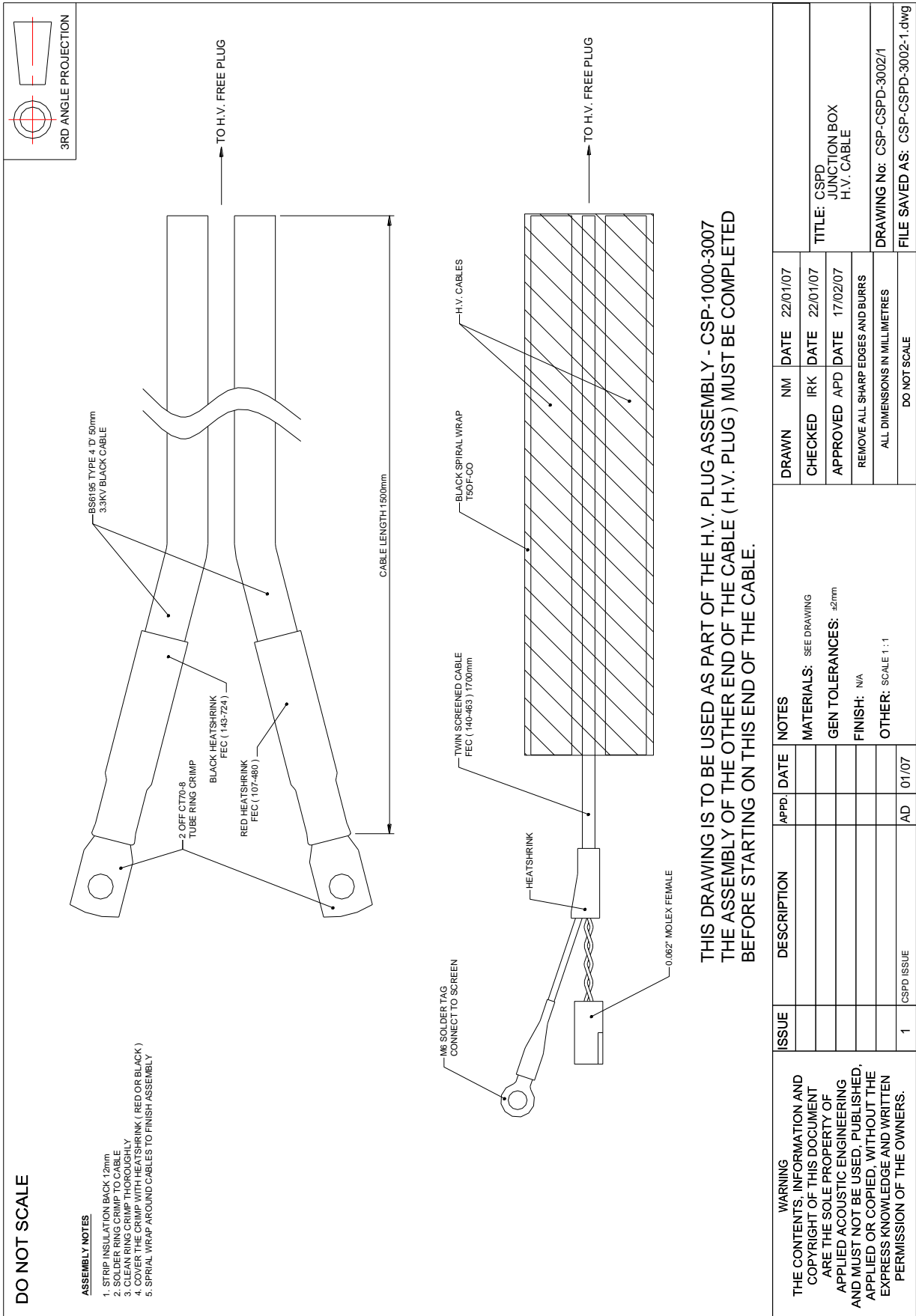

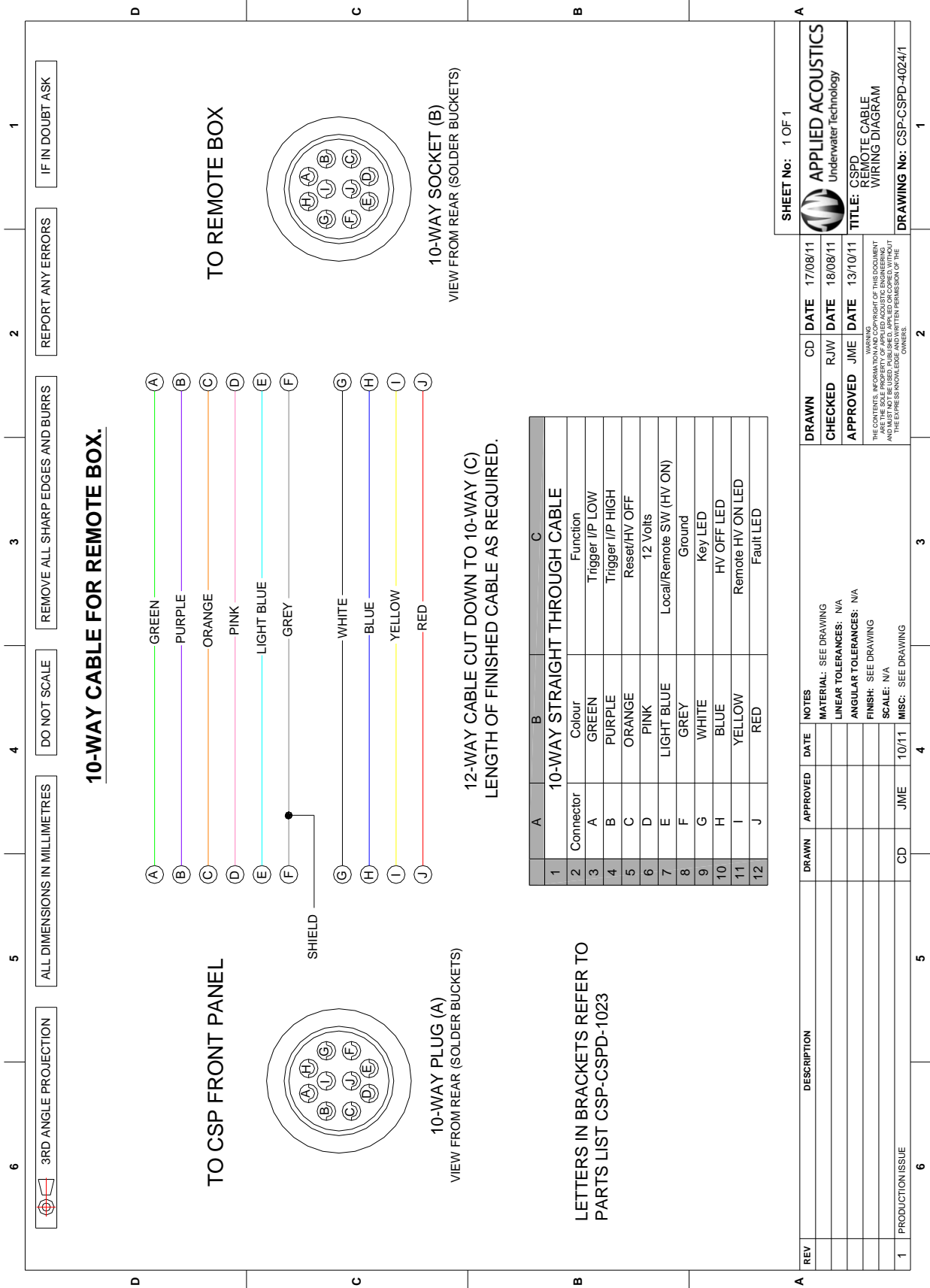

REV	DESCRIPTION	DRAWN	APPROVED	DATE	NOTES
1	PRODUCTION ISSUE	CD	JME	10/11	MISC: SEE DRAWING

DRAWN	CD	DATE	DATE	DATE	DATE
APPROVED	JME	13/10/11	18/08/11	17/08/11	17/08/11

SHEET No: 1 OF 1

APPLIED ACOUSTICS
 Underwater Technology

TITLE: CSPD REMOTE CABLE WIRING DIAGRAM

DRAWING No: CSP-CSPD-4024/1

THIS PAGE IS INTENTIONALLY LEFT BLANK

Applied Acoustic Engineering Limited is a leading company in the design and manufacture of a wide range of subsea navigation and positioning products, and marine seismic survey equipment.

The extensive product range includes the innovative USBL tracking system, Easytrak, a variety of positioning and release beacons and seismic sub-bottom profiling equipment for offshore geotechnical and seabed analysis.

All products use acoustics, underwater sound waves, in location, positioning, navigation and data acquisition applications.