



## Super SeaSpy Colour CCD Underwater Camera

### Features

- High resolution colour CCD sensor
- Standard depth rating of 4,000 metres
- Highly resistant to shock and vibration
- Wide power supply 12Vdc to 48Vdc
- LED brightness control (manual or auto)
- Wide angle version available

### Applications

- ROV inspection work
- ROV tooling package monitoring
- Harbour, river and canal inspection
- Police, customs and emergency services
- On-line industrial machinery inspection
- Restricted access areas



Super SeaSpy

The Super SeaSpy underwater video camera is a compact, high resolution, full colour camera with integral low voltage lighting.

Built to survive the harsh underwater inspection environment, the Super SeaSpy has been designed to be compact and rugged while providing a high quality colour picture.

The Super SeaSpy has integrated white ring LEDs providing uniform illumination across the viewing area. A feedback loop automatically adjusts the lighting level so that optimum picture quality is achieved, regardless of the reflectivity of work surfaces. This integral lighting provides a camera that is well suited for close proximity inspection work where little or no lighting is available.

The light can also be adjusted manually, thanks to a single wire control, compatible with several standards. In a warm environment, the LEDs are protected by a temperature sensor.

The Super SeaSpy has an internal focus adjustment that allows the focal range to be set between 50mm and infinity. The camera power supply provides excellent protection for the efficient operation of the camera module. Fitted with an integral video line driver the Super SeaSpy compensates attenuation of

the video signal when used over various umbilical lengths. This line driver is adjustable and is protected against overvoltage.

As with all Tritech cameras the Super SeaSpy is fitted with a high quality water corrected viewport to optimise the picture quality. This water corrected viewport results in a camera that provides a crisp picture during close proximity viewing in murky water.



Super SeaSpy showing size



### Specifications

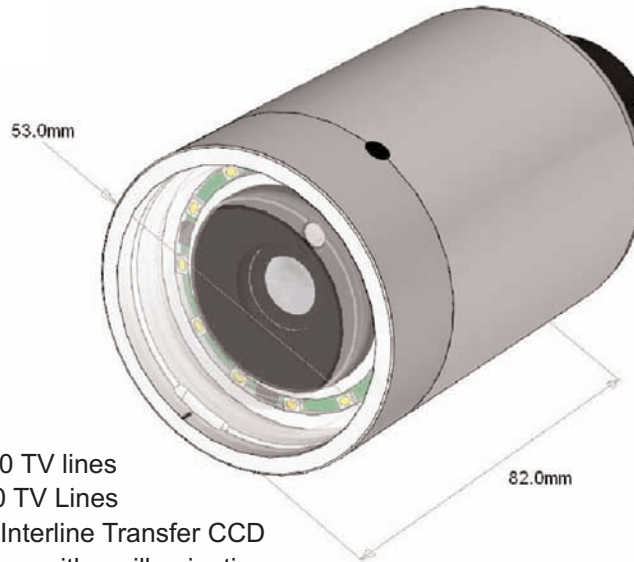

#### Video

NTSC resolution	> 480 TV lines
PAL resolution	>500 TV Lines
Sensor	1/3" Interline Transfer CCD
Sensitivity	0.5 Lux with no illumination
Iris (PAL)	50Hz 1/50 to 1/100,000 sec
Iris (NTSC)	60Hz 1/60 to 1/100,000 sec
Signal to Noise Ratio	>50dB (AGC off)
Video Output	1.0V p-p Composite, 75ohms unbalanced, protected
Video Line Drive Capability	>500m with good quality coax, with internal amplifier
Scanning System (PAL)	CCIR, 50Hz, 625 lines
Scanning System (NTSC)	RS170, 60Hz, 525 lines

#### Light

Light Control	Auto or Manual
Illumination	Ring of 12 LEDs (20.4 candela max.)

#### Power supply

Voltage	+12 to +48VDC
Power max.	4.8 Watts

#### Optics

Lens	4.3mm, F2.0
Focal Length	50mm to Infinity
Field of View (Diagonal)	70 degrees
Zoom	N.A.
Focus	Internally Adjustable

#### Environmental

Storage Temperature	-30°C to +70°C
Operating Temperature	-10°C to +40°C
Depth Rating	4000m

#### Mechanical

Housing Material	Stainless Steel
Sizes	Refer to drawing
Weight in Air	0.65kg
Weight in Water	0.45kg
Viewport	Acrylic Water Corrected
Connector	Tritech 6 Pin

"This camera is not designed for use in a helium/oxygen atmosphere"

All specifications are subject to change in line with Tritech's policy of continual product development.

Ref: EDS-CAM-004.8



#### Tritech International Limited

Peregrine Road • Westhill Business Park • Aberdeen  
AB32 6JL • United Kingdom

T: +44 (0)1224 744111  
F: +44 (0)1224 741771  
E-mail: sales@tritech.co.uk  
Website: www.tritech.co.uk

Distributed by:

#### Subsea Technologies Inc.

1323 Price Plaza Drive  
Katy, Texas 77449

Tel. : 281 398 5600  
Fax : 281 754 4401

Email: sales@subseatechnologies.com  
<http://www.subseatechnologies.com>