

TW5390



The **connection** of things.®

TW5390 Smart GNSS Antenna for Precise Positioning

Overview

The TW5390 is a multi-band (L1/L2), multi-constellation integrated GNSS receiver/antenna with Inertial Measurement Unit (Untethered Dead Reckoning) and integrated L-Band corrections receiver for stand alone RTK for Precise Point Positioning. The TW5390 is capable of providing sub 10 cm accuracy to support the most demanding navigation, automation and precision agriculture applications.

Interference Resilience

The TW5390 incorporates a latest generation multi-band (L1/L2) GNSS receiver with a Tallysman Accutenna™ multi-band (L1/L2) dual feed patch. The state of the art GNSS receiver supports concurrent tracking of all four major constellations (GPS, BeiDou, Galileo and GLONASS) in multiple frequency bands, offering high availability for RTK solutions with a quick convergence time. The multi-band (L1/L2) architecture is the most effective method for the removal of ionospheric error. The TW5390 employs multi-stage filtering with low noise figure LNAs, combined with the dual feed Accutenna™, which greatly improves the rejection of multi-path signal interference. The IMU Sensor Fusion further mitigates effects of severe multi-path reflections and provides continuous position availability during periods of GNSS outages caused by signal obstruction offering exceptional performance to meet the most challenging precise positioning applications.

Corrections Applications

The TW5390 incorporates an L-Band correction receiver which offers sub 10 cm accuracy through real-time PPP-RTK corrections via the Point Perfect subscription service. (No RTK base station is required, typical of traditional RTK applications.) The L-Band receiver offers quick convergence and continuous corrections in geographic regions without IP/Network coverage. Point Perfect streaming corrections are available in continental US and Europe.

The TW5390 may also be configured to operate with the IP/Network corrections stream when operating in a challenging urban environment where L-Band coverage may be less optimal.

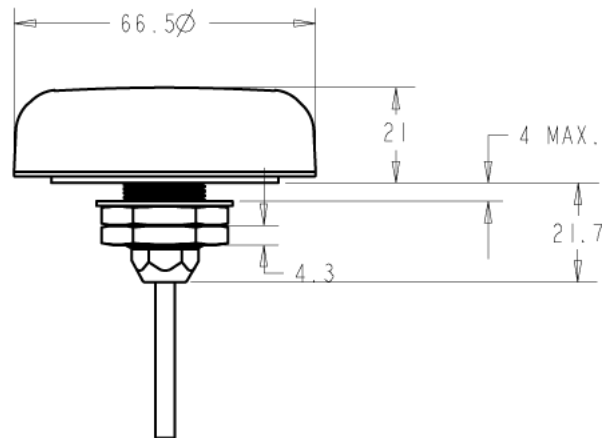

Mechanical Dimensions (mm)

Features

- Integrated L-Band corrections receiver for exceptional precision
- Improved noise immunity with multi-band GNSS receiver
- Improved multi-path rejection with Dual feed Accutenna™
- Multi-band GNSS receiver is unaffected by ionospheric errors
- High reliability timing with expansive constellation array
- High position availability in urban environment with UDR
- 5V operation
- RS-485 differential signalling
- Industrial grade IP69K enclosure
- Rugged fixed mount
- Multiple cable lengths (5m, 15m and 25m)
- Available with conical radome

TW5390 Smart GNSS Antenna

Specifications

Antenna	Electrical
Architecture.....Multi-band (L1/L2), Dual Feed	Voltages.....5 VDC
Axial Ratio.....L1: < 1 dB typical.	Current.....1 Watts (nominal operating) Measured @ 5VDC supply
Frequencies.....GPS L1C/A L2C, GLO L10F L20F, GAL E1B/C E5b, BDS B1I B2I, QZSS L1C/A L2C	Environmental
SBAS L1 C/A.....WAAS, EGNOS, MSAS, GAGAN	Operating Temperature.....-40°C to +85°C
Channels.....184-channel u-blox F9 engine	Storage Temperature.....-40°C to +85°C
Anti-jamming.....Active CW detection	Weatherproof.....IP69K
Corrections Receiver.....L-Band PPP-RTK (SSR)	Shock.....Vertical axis 50G, other axis 30G 3 axis sweep – 15 min
Signal Support.....GPS: L1 C/A, L2P, L2C, L5 3	Vibration.....10-200 Hz log sweep 3G
.....GLONASS: L1 C/A, L2 C/A	Sensitivity
.....Galileo 3: E1, E5A/B	Tracking & Nav.....-166 dBm
Corrections Data Rate.....Continental: 2400 bps	Reacquisition.....-160 dBm
Coverage.....EU and US	Hot starts.....-158 dBm
Format.....SPARTN, RTCM	Cold starts.....-147 dBm
Interface	Acquisition
Pwr, Gnd	Cold start......25 sec
Tx, RX, Timepulse.....RS-485 levels	Aided start......3 sec
Serial Protocol	Reacquisition......2 sec
Output.....NMEA 0183, UBX Binary	Position
Baud Rate.....Configurable	Standard Horizontal PVT.....1.5m CEP
Mechanical	Standard Horizontal SBAS.....1.0m CEP
Dimensions......66.5 mm dia. x 21 mm H	SPARTN Corrected Horizontal.....<0.06m CEP*
Weight......135 g	Convergence.....<45 sec
Mounting Method.....Fixed Mount	
Cable Length......5m with RJ45 termination	

Ordering Information:

33-5390-7-yy-zz-PCO (PCO = NMEA out, no adaptor cable.)

yy = Radome (00=grey conical, 10=grey low profile, 01=white conical, 11=white low profile)
zz = Cable length in meters. Standard is 5m. (15m and 25m are special order only)

TW5382 SDK Test Adaptor required for programming 33-0095-2

Please refer to the Ordering Guide for the current and complete list of available products.



The connection of things.®

Contact us:
info@tallymatics.com
T: +1 613 591-3131

Tallymatics manufactures high performance GNSS smart antennas, telematics products and solutions for a wide range of applications. With support for both RF wireless and data networks, Tallymatics enables high-resolution location awareness of mobile field assets across any type of wireless network. Tallymatics is a division of Tallysman.

Tallymatics Inc.
36 Steacie Drive,
Ottawa ON
K2K 2A9 Canada

© 2019 Tallymatics Inc. All rights reserved. Tallymatics, "The connection of things" tag line and the Tallymatics logo are trademarks or registered trademarks of Tallymatics Inc. and/or its affiliates in Canada and certain other countries. All other trademarks mentioned in this document are the property of their respective owners. The information presented is subject to change without notice. Tallysman assumes no responsibility for any errors or omissions in this document. Tallymatics is a division of Tallysman Inc. Tallymatics hereby disclaims any or all warranties and liabilities of any kind.

www.tallymatics.com