



SmartSight MV100 Operator's Manual



DeepSea Power & Light

A division of SeeScan, Inc.

4033 Ruffin Road
San Diego, CA 92123

support@deepsea.com

www.deepsea.com

WARNING!

Read this Operator's Manual carefully before using this product. Failure to understand and follow the contents of this manual may result in electrical shock, fire, and/or serious personal injury.

For support and additional information about using your DeepSea product, go to www.deepsea.com/support or scan this QR code.



Copyright © 2025 SeeScan, Inc. All rights reserved.

DeepSea Power & Light reserves the right to make changes to the design and/or the specifications of this product at any time and without prior notice. Changes made in this way come without obligation to update units already in operation. This Operator's Manual may also be changed without prior notice. The latest documentation for your product can be downloaded from www.deepsea.com/support.

Table of Contents

SmartSight MV100.....	1
Read This First!	4
Configuration.....	7
Specifications.....	10
Introduction.....	14
Troubleshooting	18
RMA Procedure for Repair	19
Warranty Information	19

Read This First!

Users and operators of the SmartSight MV100 should read and understand the information in this section of the manual in order to be familiar with important warnings, hazards, and maintenance requirements.

Safety Symbols

In this manual, safety symbols and signal words are used to communicate important safety information. This section is provided to improve understanding of these signal words and symbols.

DANGER

DANGER indicates a hazardous situation which, if not avoided, will result in death or serious injury.

WARNING

WARNING indicates a hazardous situation which, if not avoided, could result in death or serious injury.

CAUTION

CAUTION indicates a hazardous situation which, if not avoided, could result in minor or moderate injury.

NOTICE

NOTICE indicates information that relates to the protection of property or proper function of the device.



This symbol means read the operator's manual carefully before using the equipment. The manual contains important information on the safe and proper operation of the equipment



This symbol means always wear safety glasses with side shields or goggles when handling or using this equipment to reduce the risk of eye injury



This symbol indicates the risk of electrical shock.



This symbol indicates the risk of explosion.

General Safety Rules

Read all safety warnings and instructions. Failure to follow the warnings and instructions may result in electrical shock, fire, explosion, and/or serious injury.

SAVE THESE INSTRUCTIONS!

DANGER

High Voltage Equipment



Do not operate any high voltage equipment in or around water without using a Ground Fault Circuit Interrupter (GFCI) and an isolation transformer, especially when divers are in the water.

WARNING

Improper Use and Handling



- Whenever possible, subsea electronic systems should be connected to either an active or passive cathodic protection system such as a network of anodes to prevent corrosion of critical components when deployed.
- This product can be configured with a variety of standard pinouts and will be shipped with a pinout label identifying the connector type and the internal connections of power and control signals. Always check the pinout of the unit against the system specifications prior to installation.
- This product operates on low voltage DC power anywhere from 10V DC up to 48V DC. Connecting the unit to a power source outside this range may result in malfunction or damage to the item.
- Never place the pressure housing in a vice or other hard clamping tool unless explicitly instructed to do so in this manual. Should it become necessary to hold onto the unit tighter than can be managed by hand, use a clean and good quality strap wrench.

DANGER

Flooded Housing



A flooded or partially flooded housing presents a significant hazard of both electrical shock and explosion. Water in contact with internal electronics may short to the housing, exposing users to potentially dangerous voltages. It is also possible that water in contact with internal electrical circuits may electrolyze, producing an explosive mixture of hydrogen and oxygen gasses trapped inside the pressure vessel.

For safety reasons, always assume the camera has flooded and take necessary precautions if it stops working underwater. When working with a potentially flooded camera, it is important to use appropriate personal protective equipment (PPE) to include, at a minimum, eye and hand protection and protective clothing.

Follow these steps if the pressure housing becomes flooded or is suspected of flooding:

1. Immediately power off the unit.
2. Put on appropriate PPE, including protective clothing, eye protection, and protective gloves.
3. Relieve any internal pressure by venting the PRV or loosening the bulkhead connector from the unit.
4. Remove the rear endcap retaining ring and then lever the endcap off with a flat blade screwdriver using the groove just forward of the connector mating surface. The endcap should separate in a smooth linear motion. No twisting is necessary.
5. Pour out any water trapped inside the housing.
6. If the unit is flooded, rinse the internal components with clean, fresh water in order to minimize contamination and corrosion damage.
7. Allow parts to dry in air or in an oven set to 60°C (140°F).

NOTICE

Proper Cables and Interconnects



This product transmits data over high-speed serial interfaces using controlled impedance transmission lines such as 100Ω differential pairs. Use of controlled impedance connectors and cables designed for subsea applications is critical to the proper operation of the unit.

WARNING

Field Service and Modification



Except for when specifically instructed, this product does not require the user to open the pressure volume or break the factory validated high pressure seals to operate. Opening the pressure volume creates a risk of contamination of the high-pressure seal surfaces which may result in water intrusion and failure.

This product is configured for optimal function at the factory. Opening and modifying any of the factory configured hardware, such as the lens assembly, can affect focus and imaging performance. Access to or modification of the internal components should not be attempted without the guidance of a qualified service representative.

NOTICE

Pre and Post Dive Inspection



Before deployment, always check to make sure the bulkhead connector assembly is secure.

Prior to and following each deployment, perform a visual inspection of the following areas for damage, wear, or corrosion:

- Bulkhead connector assembly
- Interconnect cable
- Optical port
- Port retainer and pressure housing

Rinse the unit with fresh water after use, especially in saltwater environments.

Customer Service

DeepSea Power & Light provides service to our global customers through our Service and Repair department. Contact DeepSea Support with comments, suggestions, and feedback, or to request service or support for your product.

To learn more about this product, along with the other products and services provided by DeepSea Power & Light, please visit www.deepsea.com or reach out to us at support@deepsea.com.

Configuration

The SmartSight MV100 is highly configurable and can be specified with a range of lens, sensor, housing, and connector options to maximize utility and ease integration with existing platforms.

Sensor Options

The SmartSight MV100 can be fitted with a range of Sony Pregius global shutter sensors, from the large pixel pitch and high sensitivity of the 0.4MP sensor up to the better-than-HD resolution 3.2MP option. All sensors are also available in either color or monochromatic pixel array options depending on the application requirements.

Sensor selection impacts features beyond just resolution and sensitivity. The pixel pitch and array size determine the diagonal size of the sensor, which changes the area of the image projected by the lens captured in each exposure. As a result, a sensor with a larger sensor size will have a wider field of view compared to a smaller sensor using the same lens.

Sensor Option	Sony IMX287	Sony IMX273	Sony IMX392	Sony IMX265
Sensor Resolution	0.4 MP	1.6 MP	2.3 MP	3.2 MP
Sensor Size	6.3 mm	6.3 mm	7.9 mm	8.9 mm
Pixel Array	720 x 540	1440 x 1080	1920 x 1200	2048 x 1536
Pixel Size	6.9 μm x 6.9 μm	3.45 μm x 3.45 μm	3.45 μm x 3.45 μm	3.45 μm x 3.45 μm
Frame Rate	286 FPS	71.6 FPS	48.3 FPS	35.4 FPS
LLC Frame Rate ¹	350 FPS	111 FPS	80 FPS	51 FPS
Sensor Type	Color, Mono	Color, Mono	Color, Mono	Color, Mono
Shutter	Global	Global	Global	Global

Lens and Port Options

The field of view of a particular configuration is determined by the size of the image sensor, focal length of the lens, and the type of optical port fitted to the unit. Flat ports have a reduced field of view in water compared to operation in air, but the optimal focus is the same in either condition. Dome ports maintain the same field of view in air and water, but are not able to focus in air and appear near-sighted until underwater where they are optimally focused. For more information on this topic, see our knowledgebase article here:

<https://www.deepsea.com/dome-view-ports-best-performance-under-pressure/>

The table below shows the compatible lens and housing port options and provides the model number reference corresponding to that lens and port combination.

LENS	PORT	
	Glass Flat Port	Glass Dome + Crash Guard
6 mm, f/4.0	MV100-F-TI-___-060	
2.7 mm, f/2.9	MV100-F-TI-___-027	MV100-D-TI-___-027
2.33 mm, f/2.9		MV100-D-TI-___-023

Table 1 – SmartSight MV100 Port and Lens Options

¹ LLC = Lossless Compression. Option only available on select BFS type modules.

Sensor Option	6mm/Flat	2.7mm/Flat	2.7/Dome	2.3mm/Dome
0.4 MP	32°	67°	101°	117°
1.6 MP	32°	67°	101°	117°
2.3 MP	40°	80°	105°	125°
3.2 MP	43°	83°	120°	N/A

Table 2 - Available Field of View by sensor and lens/port option

Housing Options

The SmartSight MV100 is available in both flat and dome port housing options, each offering different lens and field of view configurations (see Table 2).

Housing selection also affects the depth limit options of the camera. Flat port options are limited to 6,000 m, and dome port housings are available in both 6,000 m and 11,000 m configurations. While a 6,000 m and an 11,000 m housing look the same externally, there are internal differences between the dome seat and support geometry in either housing to achieve the higher pressure rating.

NOTICE

Bulkhead Connector Selection



Regardless of the housing configuration, bulkhead connectors should be chosen that meet or exceed the housing's operating depth limits. **If a customer-specified connector does not meet the housing's pressure rating, the connector will limit the camera's factory certified depth rating.**

Power Options

SmartSight MV100 cameras can be powered with either a discrete 10-48 VDC input voltage or by utilizing a Power over Ethernet (PoE) connection, which superimposes a DC voltage (usually 48 VDC) onto the wire pairs carrying data signals to the camera. The PoE feature of the MV100 camera is compliant with IEEE 802.3af-2003 standards.

If both discrete power and PoE power are applied to the camera, the MV100 hardware will default to drawing power from the discrete input.

Discrete Input and Output Options

The SmartSight MV100 hardware provides electrically isolated discrete input and output pins that can be wired to the bulkhead and provide external control and synchronization functions. If these features are required, a bulkhead with sufficient pins to support power, Ethernet, and these I/O functions needs to be selected. The default SubConn DBH13M is the recommended connector for most applications as it provides four discrete conductors (plus a shield) supporting power and discrete input and output signals in addition to the 8-pins needed for gigabit Ethernet communications.

Catalog Configuration Reference

Example Configuration:		MV100	-D	-TI	-BFS	-023	-C	-027	-I	-SUDBH13M/S	13C009	
MODEL		MV100 = SmartSight MV100										
PORT		D = DOME F = FLAT										
HOUSING		TI = Titanium, 6,000m 11 = Titanium, 11,000m (DOME PORT ONLY)										
MODULE		BFS = FLIR Blackfly S Series										
RESOLUTION		004 = 0.4MP, 720x540, 6.9µm pixel, Global Shutter 016 = 1.6MP, 1440x1080, 3.45µm pixel, Global Shutter 023 = 2.3MP, 1920x1200, 3.45µm pixel, Global Shutter 032 = 3.2MP, 2048x1536, 3.45µm pixel, Global Shutter										
CHROMA		C = RGB Color M = Monochrome										
LENS		023 = 2.3 mm F/2.8 (DOME PORT ONLY) 027 = 2.7 mm F/2.9 (DOME OR FLAT PORT) 060 = 6.0 mm F/5.6 (FLAT PORT ONLY)										
BRACKET		M = Metric M6 Saddle Bracket I = Imperial 1/4-20 Saddle Bracket										
CONNECTOR		SUDBH13M/S = SubConn DBH13M SS Ethernet SUDBH8M/S = SubConn DBH8M SS Ethernet										
PINOUT		PINOUTS – SEE PINOUT TABLE ON PAGE 11 13C009 = use for SUDBH13M/S, discrete or PoE power, 1000 Gbps, discrete input and output 08E021= use for SUDBH8M, discrete power, 10/100 Mbps limited, no discrete I/O 08E025= use for SUDBH8M, PoE power, 1000 Gbps capable, no discrete I/O										

EXAMPLE CONFIGURATIONS

MODEL	PORT	HOUSING	MODULE	RESOLUTION	CHROMA	LENS	BRACKET	CONNECTOR	PINOUT
MV100	F	TI	BFS	032	C	060	M	SUDBH13M/S	13C009
MV100	D	TI	BFS	004	M	027	I	SUDBH8M/S	08E025

Specifications

Optical Specifications				
Model	MV100-D-T-BFS		MV100-F-T-BFS	
<i>Lens Options</i>	2.3mm F/2.8	2.7mm F/2.9	2.7mm F/2.9	6.0mm F/5.6
<i>Sensor Options</i>	0.4MP, 1.6MP, 2.3MP, 3.2MP Global Shutter			
Environmental Specifications				
Model	MV100-D-T-BFS		MV100-F-T-BFS	
<i>Max Depth</i>	6000 m (11,000 m option*)		6000 m	
<i>Operating Temp</i>	-10 to 40°C [14°F to 104°F]			
<i>Storage Temp</i>	-30 to 60°C [-22°F to 140°F]			
Mechanical Specifications				
<i>Housing</i>	Titanium housing		Titanium housing	
<i>Optical Port</i>	Borosilicate Dome Port		Borosilicate Flat Port	
<i>Mounting Bracket</i>	Saddle bracket with either metric M6 or 1/4-20 imperial titanium inserts			
<i>Weight in Air</i>	0.65 kg [1.4 lbs.]		0.65 kg [1.4 lbs.]	
<i>Weight in Water</i>	0.37 kg [0.84 lbs.]		0.44 kg [1.0 lbs.]	
Electrical Specifications				
<i>Interface</i>	10/100/1000 BaseT Ethernet, GigE Vision v1.2 Compliant			
<i>Inputs/Outputs</i>	Isolated: 1 IN, 1 OUT			
<i>Power</i>	2.7W maximum			
<i>Voltage</i>	10-48VDC, PoE IEEE802.3af-2003			
<i>Standard Connector</i>	SubConn DBH13M Stainless Steel			

*Please contact Sales for applications requiring 11,000 m rating.

Standard Pinout Information

WARNING



Always verify the pinout of your product against the printed pinout label or documentation supplied with your product before connecting with other systems or powering the device. DeepSea is not responsible for damage caused by improper wiring or incorrect power applied to the product. If you are unsure of how your item is pinned out, contact us at support@deepsea.com and provide the model number, purchase order and serial number of your item and we will provide a pinout drawing for your product.

The following pinouts are considered “standard” conventions by DeepSea. We strongly urge all of our customers to adhere to these conventions to avoid accident and potential injury. DeepSea is not responsible for damage caused by improper wiring, incorrect power applied to the product, or by using a non-standard pinout.

Standard Pinout Reference

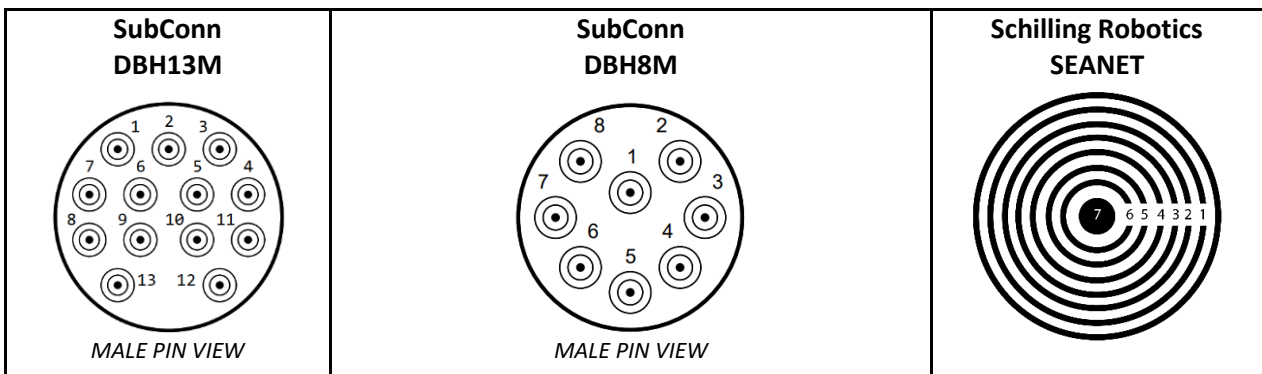

PIN	Ethernet Camera Discrete Power 10/100/1000 Mbps	Ethernet Camera Discrete Power 10/100Mbps	Ethernet Camera PoE 10/100/1000 Mbps	IP Camera NIM
1	DC-	DC-	TxRx D- 0V PoE	DC+
2	SCREEN	DC-	TxRx D+ 0V PoE	DC-
3	DC+	DC+	TxRx C+ 48V PoE	CHASSIS
4	TxRx D-	DC+	TxRx C- 48V PoE	RD-
5	TxRx D+	TD-	TxRx A- TD-	RD+
6	TxRx C+	TD+	TxRx A+ TD+	TD-
7	TxRx C-	RD-	TxRx B- RD-	TD+
8	TxRx A-	RD+	TxRx B+ RD+	
9	TxRx A+			
10	TxRx B-			
11	TxRx B+			
12	OPTO OUT			
13	OPTO IN			
ID	13C009	08E021	08E025	07E004

Dimensions

Flat Port Housing Configurations

Unit shown with SubConn DBH8M bulkhead option

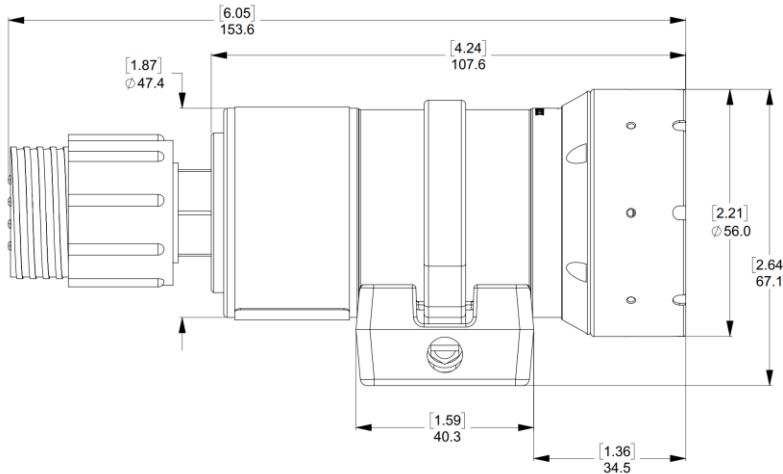

Units: mm[inch] | Scale: 2:1 | View Orientation: STARBOARD (RIGHT SIDE) |

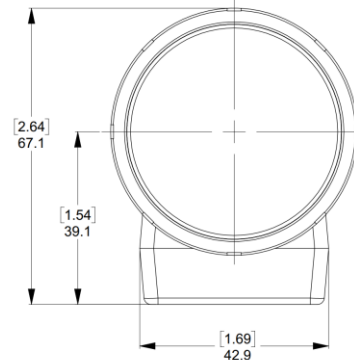

Units: mm[inch] | Scale: 2:1 | View Orientation: FORWARD |

Dome Port Housing With Cowl Configurations

Unit shown with SEA-CON MCBH8 Ethernet bulkhead option

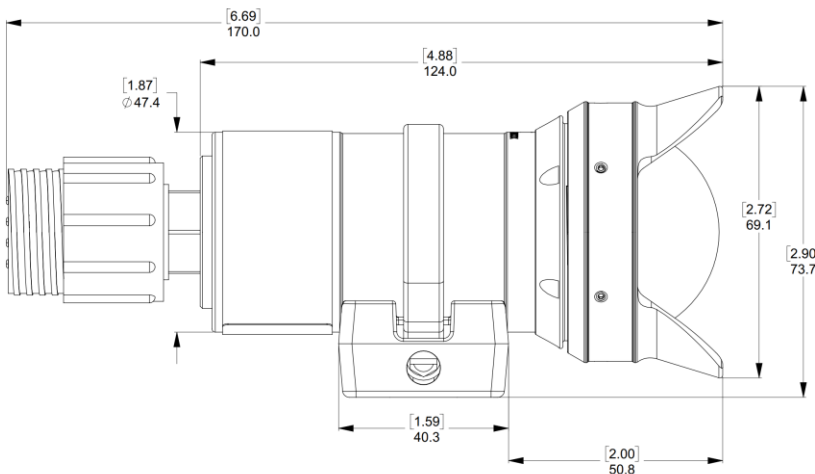

Units: mm[inch] | Scale: 2:1 | View Orientation: STARBOARD (RIGHT SIDE) |

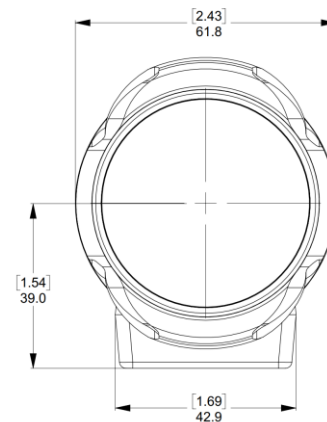

Units: mm[inch] | Scale: 2:1 | View Orientation: FORWARD |

Dome Port Housing Without Cowl Configurations

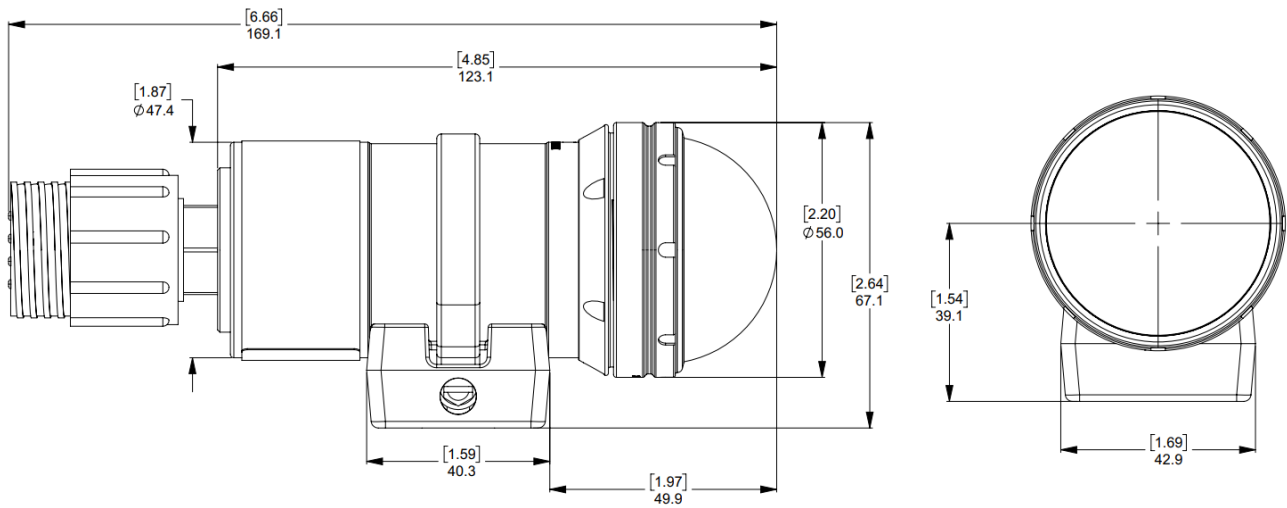

Units: mm[inch] | Scale: 2:1 | View Orientation: STARBOARD (RIGHT SIDE) |

Units: mm[inch] | Scale: 2:1 | View Orientation: FORWARD |

Mounting Bracket Options

SmartSight MV100 cameras are provided with a standard saddle bracket with titanium inserts in either imperial 1/4"-20 or metric M6 threads.

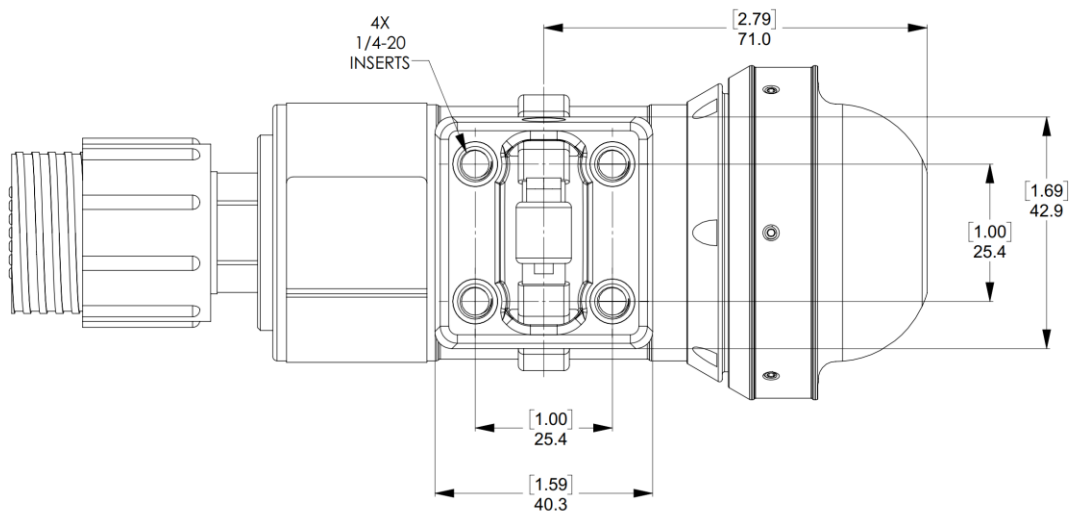

Units: mm[inch] | Scale: 2:1 | View Orientation: BOTTOM |

Introduction

DeepSea Power and Light's SmartSight MV100 family of machine vision cameras combines best-in-class gigabit Ethernet machine vision camera modules, underwater optics, proven subsea housings, and proprietary electronics that extend the utility of these cameras beyond their out-of-the-box features. The MV100 platform is the first foray into machine vision systems for DeepSea and is targeted at the most demanding subsea artificial intelligence (AI), machine learning (ML), and computer vision (CV) applications.

As a machine vision camera, the SmartSight MV100 is designed to be integrated as an element in a larger control system for image data acquisition. Uncompressed image data is sent over Ethernet to a host device at up to a gigabit per second.

The SmartSight MV100 is built on the HD Multi SeaCam platform, which allows for a wide range of configuration options such as different resolution sensors, various focal length lenses, and flat and dome port configurations, which can be mixed and matched to configure the camera for a large variety of applications. The electrical and mechanical interface is standardized which allows these cameras to be interoperable in most configurations and provides operational flexibility.

External Description

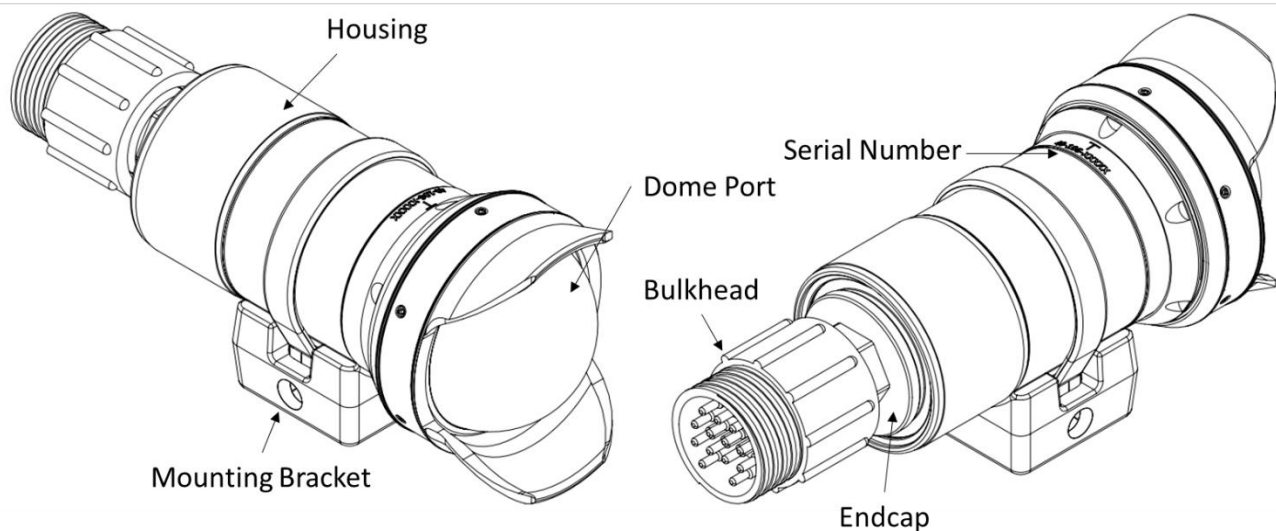

Controlling the Camera

Control of the MV100 camera is provided through a set of Application Programming Interfaces (APIs) and Software Development Kits (SDKs) that handle low-level configuration of everything from the network options to exposure settings and discrete I/O controls.

- **FLIR Spinnaker SDK and SpinView GUI:** <https://www.flir.com/products/spinnaker-sdk/>

The Spinnaker SDK is provided by FLIR and supports its Blackfly S and other families of machine vision cameras. FLIR's SDK is a multi-platform, multi-language, high reliability solution for controlling and collecting image data from SmartSight BFS series machine vision cameras. FLIR also provides a graphical user interface (GUI) application built on the Spinnaker SDK to accelerate development, aid troubleshooting, and assist in the configuration of the Blackfly S module used in the MV100 family. This SDK is not maintained by DeepSea Power and Light.

- **SmartSight SDK and GUI:** https://files.seescan.com/url/mv100_gui_software

DeepSea's SmartSight SDK and example GUI application provide an extension of the Spinnaker SDK and automate many of the additional features provided by the MV100 platform. These features include input power configuration, input/output triggering, and field firmware updates. The SmartSight SDK is currently limited to Windows 10 or higher and is only available as a Python distribution.

Resolution, Sensitivity, and Frame Rates

Frame rate and resolution can be traded off to fit the available bandwidth of the Ethernet connection between the SmartSight MV100 camera and the host system. The MV100 camera module balances design and application tradeoffs through multiple features. Binning (additive and averaging), where adjacent pixels on the sensor are combined in either a 2x2, 3x3, or 4x4 fixed pattern, reduces the effective resolution to enable higher frame rates as a result. Additive binning can also be leveraged to improve the sensitivity of the camera by summing adjacent pixel values, resulting in the appearance of having one larger pixel.

Discrete Input/Output Pins

All SmartSight cameras are equipped with optically isolated discrete input and output pins that can be assigned to multiple functions, such as triggering an image capture or synchronizing an external strobe light with the image exposure period.

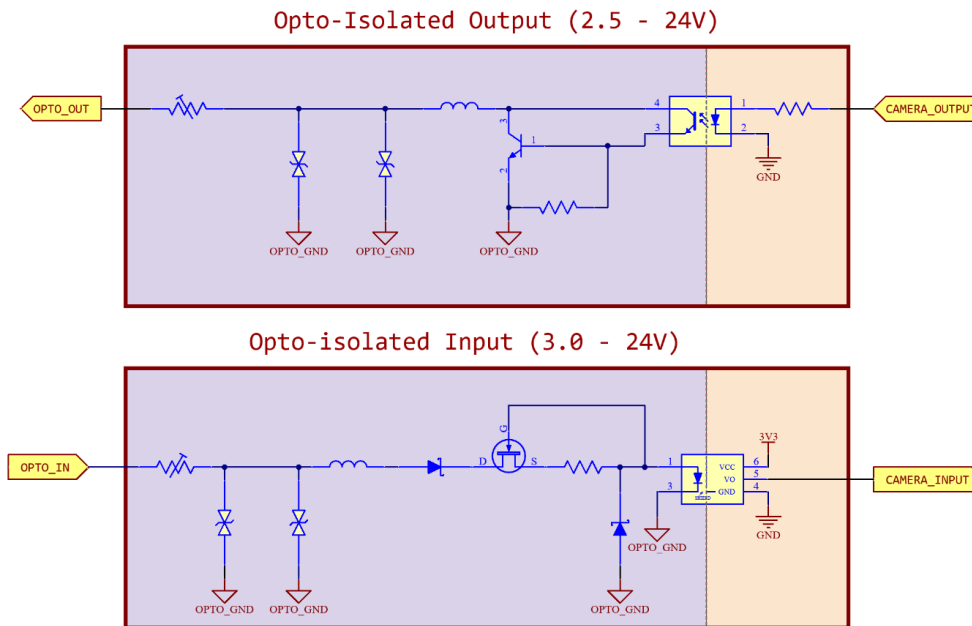

Figure 1 - Schematic of isolated discrete input and output pins

The discrete input and output pins can be mapped to various functions including onboard timers, software triggers, and the exposure trigger controls, enabling a broad range of application integration options. Common I/O configurations include:

Map	Example Function
Map discrete input to exposure trigger	Command the camera to take an image or start a sequence of image captures.
Map output pin to Exposure Active signal from the camera	Synchronize external lighting with an image capture.
Connect output trigger of one camera to input trigger of a second camera	Synchronize exposure of both cameras in a stereo vision application.

Table 3 - Common I/O Configurations

NOTICE

Triggering Input/Output Limitations



Due to underlying limitations of the FLIR Blackfly S camera module, **discrete input and output functions are not available concurrently**. Only the discrete input is available when operating off a PoE power source.

Input Power Mode	Pin Function Available?	
	Isolated Input	Isolated Output
Discrete 10-48VDC	YES	YES
Power over Ethernet	NO	YES

Integration Procedure

Unpacking

The SmartSight MV100 camera package includes:

- SmartSight MV100 camera
- Quick-Start Guide – includes QR codes linking to support and technical reference pages

Connecting to Your MV100 for the First Time

1. Prepare a host computer with an Ethernet port along with either a PoE switch or a discrete power supply 10~48 V.

Note: It is not recommended to connect both power sources, as this can create ground loops or unintentionally create connections between networking equipment and separate power supplies.

However, the camera will prioritize discrete power over PoE when both power sources are available.

2. Prepare the camera bulkhead connector as required, verifying proper lubrication of all O-rings and seal surfaces with a silicone lubricant (spray recommended).
3. Mate the female underwater connector to the male bulkhead using a smooth linear motion, making sure the connectors are fully seated, and that the seals are engaged.
4. Screw the locking sleeves together firmly by hand. **Do not use tools.** Tightening locking sleeves with tools may result in damage from over-tightening.
5. Connect the camera to the host PC: Plug the camera into the Ethernet port of the host PC. Refer to the pinout diagram on page 11 for specific details.
Note: If using PoE, connect the camera to the PoE switch and the switch to the host PC.
6. Provide power to the camera: Power the camera using either Power over Ethernet (PoE) or the discrete power supply. Refer to the pinout diagram for further details.
7. Set up the camera: Follow the MV100 Quick Start Guide for easy setup and configuration instructions to quickly access the advanced features of the MV100 system.

The Quick-start Guide and other software tools and documentation can be sourced from the SmartSight MV100 Product Knowledgebase site.

Link: <https://q.dspl.com/mv100-help/>

Care and Maintenance

The SmartSight MV100 camera is designed to require minimal maintenance for proper operation and a long service life. Maintaining your MV100 camera according to the below timeline will help prolong the life of your equipment.

After every dive...

- Rinse the camera with fresh water to prevent buildup of salt and mineral deposits outside seals.

Every year...

- Disconnect the inline connector from the camera and visually inspect for any signs of corrosion, water intrusion, wear, or damage to the pins and shell of the mating connector and bulkhead.
- Clean all pin and bulkhead seals and apply fresh lubrication to O-rings and rubber molded pins as necessary.
- Look over the housing for any indications of mechanical damage sustained during subsea operations.
- Visually inspect the optical port for any signs of moisture, cracks, or water intrusion.
- Check for feature and software updates on the SmartSight MV100 product website, www.dspl.com/mv100.

Every five years...

- In addition to the normal annual maintenance, remove the camera from operation and return to DeepSea for a high-pressure seal replacement service. You may also contact our support team for instructions on performing this maintenance in the field at support@deepsea.com.

Troubleshooting

1. If the MV100 stops working while underwater, always assume that it has been flooded. See Flooding Repair procedure on page 5.
2. If it has been determined that the unit is not flooded, or if it does not power on during pre-deployment checks, troubleshoot the product in the following sequence:
 - a. Check the cable/inline connector to make sure that correct voltage and current are being supplied, and that the pin-out matches the MV100 being used. See page 10 of this manual for electrical specs and standard connector pin-outs.
 - b. Remove the endcap to access the bulkhead connector. Inspect the assembly for visual signs of wear. Use a multi-meter check for continuity or shorts in the connector. Try a spare connector, if available.
 - c. If the MV100 still does not work, return it to DeepSea Power & Light using the RMA Procedure.

Resources

Additional information and troubleshooting guides for your product may be available on our Customer Help site at <https://help.deepsea.com/support/home>. Create an account there to access the broadest range of content on our products.

RMA Procedure for Repair

Should it be necessary to return your product to the factory, follow the Flooding Repair procedure on page 5. Leave the connector partially unscrewed before shipping the product to DeepSea Power & Light.

For warranty and non-warranty repairs, please contact DeepSea Power & Light for an RMA number prior to returning your item. Provide the product's model number, serial number, and any other pertinent information along with a description of the problem when you request the RMA. You may request an RMA via:

- **Phone:** + 1 (858) 576-1261
- **Email:** RMA@deepsea.com
- **RMA form on our website:** <https://www.deepsea.com/return-material-authorization/>.

When shipping your item, be sure that the freight is pre-paid (CODs will not be accepted) and that the RMA number is clearly printed on the outside of the box. All shipments should be sent to the address below:

DeepSea Power & Light

Attn: RMA #####

4033 Ruffin Road

San Diego, CA 92123-1817

U.S.A

Tel: (858) 576-1261

Fax: 858-576-0219

Email: RMA@deepsea.com

Warranty Information

Limited Warranty

Seller warrants that the goods (except internal electronic components) sold under this contract will be free from defect in material and workmanship for a period of one year from the date of shipment from the factory, if they have been properly used. Internal electronic components are warranted for 90 days from the date of shipment from the factory, if they have been properly used. This warranty will be limited to the repair or replacement of parts and the necessary labor and services required to repair the goods. IT IS EXPRESSLY AGREED THAT THIS WARRANTY WILL BE IN LIEU OF ALL WARRANTIES OF FITNESS AND IN LIEU OF THE WARRANTY OF MERCHANTABILITY. This warranty is the exclusive and only warranty to pass with the goods under this contract. No agent, employee, or representative of the Seller has any authority to bind Seller to any information, representation, or warranty concerning the goods sold under this contract, and unless an affirmation, representation, or warranty made by an agent, employee, or representative is specifically included within this contract, it will not be enforceable by Buyer. If notice of defect is given to DeepSea Power & Light within such 90 day or one-year warranty period, the sole obligation of DeepSea Power & Light shall be to furnish new or repaired parts free of charge in exchange for parts which have been proved defective and does not include any other costs such as the cost of removal of the defective part, installation, labor, or consequential damages of any kind, the exclusive remedy being to require DeepSea Power & Light to furnish such new parts. Under no circumstances shall the Buyer be entitled to recover any incidental damages as that term is defined in Commercial Code §2715.