

BLOCK AND CIRCUIT DIAGRAMS

Section 3

CONTENTS - Section 3**PAGE**

1	Introduction.....	4
---	-------------------	---

DRAWINGS**PAGE**

1	CSP-1000-5000/D	CSP Control Brd Schematic 1 of 2	5
2	CSP-1000-5000/D	CSP Control Brd Schematic 2 of 2	6
3	CSP-1000-5002/C	CSP Relay Brd Schematic	7
4	CSP-1000-5003/C	CSP Key In Brd Schematic	8
5	CSP-1000-5017/A	CSP Thyristor Int Brd Schematic	9
6	CSP-CSPD-5001/A	CSPD HV Detect Brd Schematic	10
7	CSP-CSPD-5002/1	CSPD HV Monitor Brd Schematic	11
8	CSP-CSPD-4021/A	CSPD Control Wiring	12
9	CSP-CSPD-4010/1	CSPD HV Wiring	13
10	CSP-CSPD-1009/1	CSPD Thyristor Assembly	14
11	CSP-CSPD-1011/1	CSP High Voltage Plug Assembly	15
12	CSP-CSPD-1012/1	CSP High Voltage Plug Component Assembly	16
13	CSP-CSPD-3002/1	CSP Junction Box HV Cable	17
14	CSP-1000-4012/C	Remote Box Wiring	18
15	CSP-1000-4007/C	Remote Cable Wiring	19

INTRODUCTION TO SECTION 3

Section 3 contains schematics only. For circuit descriptions refer to Section 2.

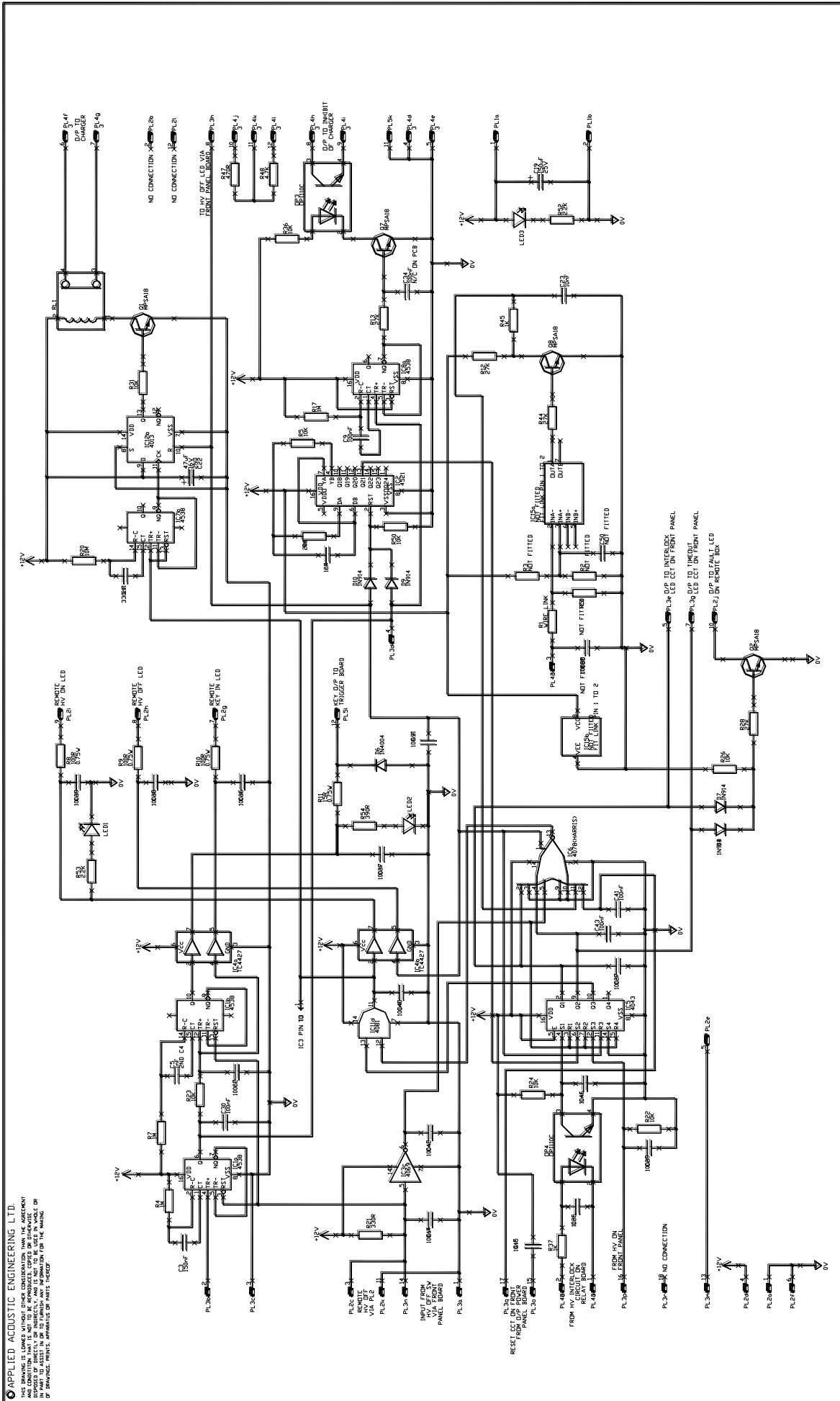

APPLIED ACOUSTIC ENGINEERING LTD.
 ALL RIGHTS RESERVED. THE DESIGN AND CONSTRUCTION OF THIS BOARD IS THE PROPERTY OF APPLIED ACOUSTIC ENGINEERING LTD. AND IS NOT TO BE REPRODUCED, COPIED OR OTHERWISE USED IN ANY MANNER WITHOUT THE WRITTEN PERMISSION OF APPLIED ACOUSTIC ENGINEERING LTD. IN PART TO ASSIST IN OR TO FULFILL ANY OBLIGATION FOR THE MANUFACTURE OF SIMILAR PRINTS. APPEARANCE OF PARTS THEREOF

ISSUE	DESCRIPTION	APPD DATE	ALL DIMS IN mm	NOT TO SCALE	APPLIED ACOUSTIC ENGINEERING LTD.	DRAWN MG	DATE 01/05/08	TITLE
D	CSPD MDS DCR 325	APD 1/07	MATERIAL		APPLIED ACOUSTIC ENGINEERING LTD.	CHECKED NM	DATE 31/01/07	CSP1000 CONTROL BOARD CIRCUIT DIAGRAM SHEET 1 OF 2
C	REDRAW REMOVING ERRORS	APD 5/08	FILE NAME CTRL BOARD 1.SCH		APPLIED ACOUSTIC ENGINEERING LTD.	APPROVED	DATE	DRAWING No. CSP-1000-5000/D

APPLIED ACOUSTIC ENGINEERING LTD.
 THE COMPANY SHALL NOT BE RESPONSIBLE FOR THE DESIGN OR CONSTRUCTION OF THE BOARD OR THE PERFORMANCE OF THE BOARD UNDER ANY CONDITIONS OF USE OR OPERATION.
 THE COMPANY SHALL NOT BE RESPONSIBLE FOR THE DESIGN OR CONSTRUCTION OF THE BOARD OR THE PERFORMANCE OF THE BOARD UNDER ANY CONDITIONS OF USE OR OPERATION.
 THE COMPANY SHALL NOT BE RESPONSIBLE FOR THE DESIGN OR CONSTRUCTION OF THE BOARD OR THE PERFORMANCE OF THE BOARD UNDER ANY CONDITIONS OF USE OR OPERATION.

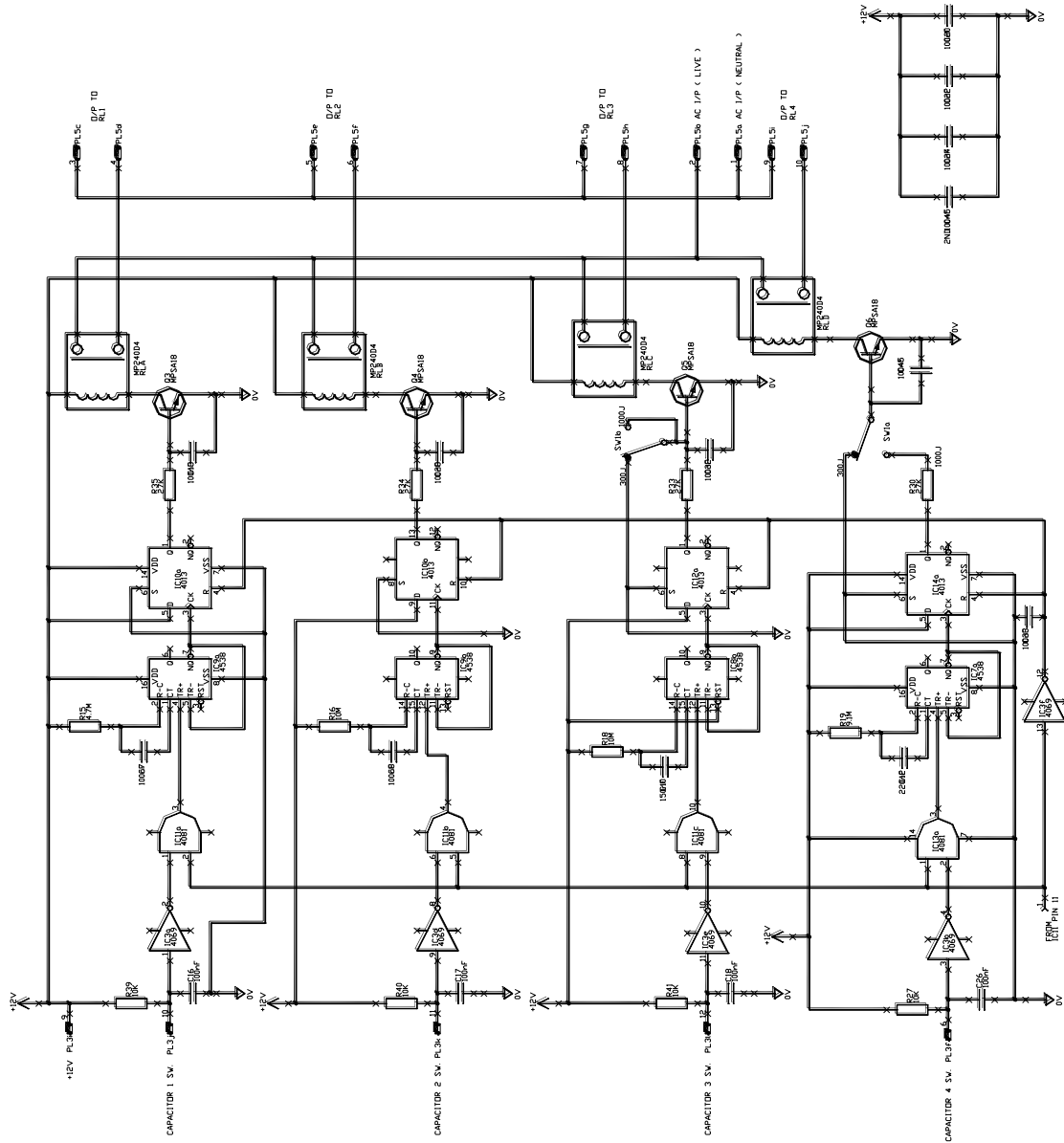

ISSUE	DESCRIPTION	APPD	DATE	ALL DIMS IN mm	NOT TO SCALE
D	CSPD ISSUE DCR 325	APD	1/07	MATERIAL	
C	REDRAW REMOVING ERRORS	APD	5/02	FILE NAME CTRL BOARD CSPD.SCH	

APPLIED
 ACOUSTIC
 ENGINEERING
 LTD.

DRAWN	MG	DATE
CHECKED	NM	31/01/07
APPROVED		

TITLE
 CSP1000 CONTROL BOARD CIRCUIT DIAGRAM SHEET 2 OF 2

DRAWING No.
CSP-1000-5000/D

APPLIED ACOUSTIC ENGINEERING LTD. IS NOT RESPONSIBLE FOR CONSIDERATION THAN THE AGREEMENT OF THE USER. THIS DRAWING IS TO BE USED AS A REFERENCE ONLY AND NOT TO BE REPRODUCED COPIED OR OTHERWISE DISPOSED OF DIRECTLY OR INDIRECTLY, AND IS NOT TO BE USED IN WHOLE OR IN PART TO ASSIST IN OR TO FURNISH ANY INFORMATION FOR THE MAKING OF DRAWINGS, PRINTS, APPARATUS OR PARTS THEREOF.

(CONNECTOR INTERLOCK PINS)

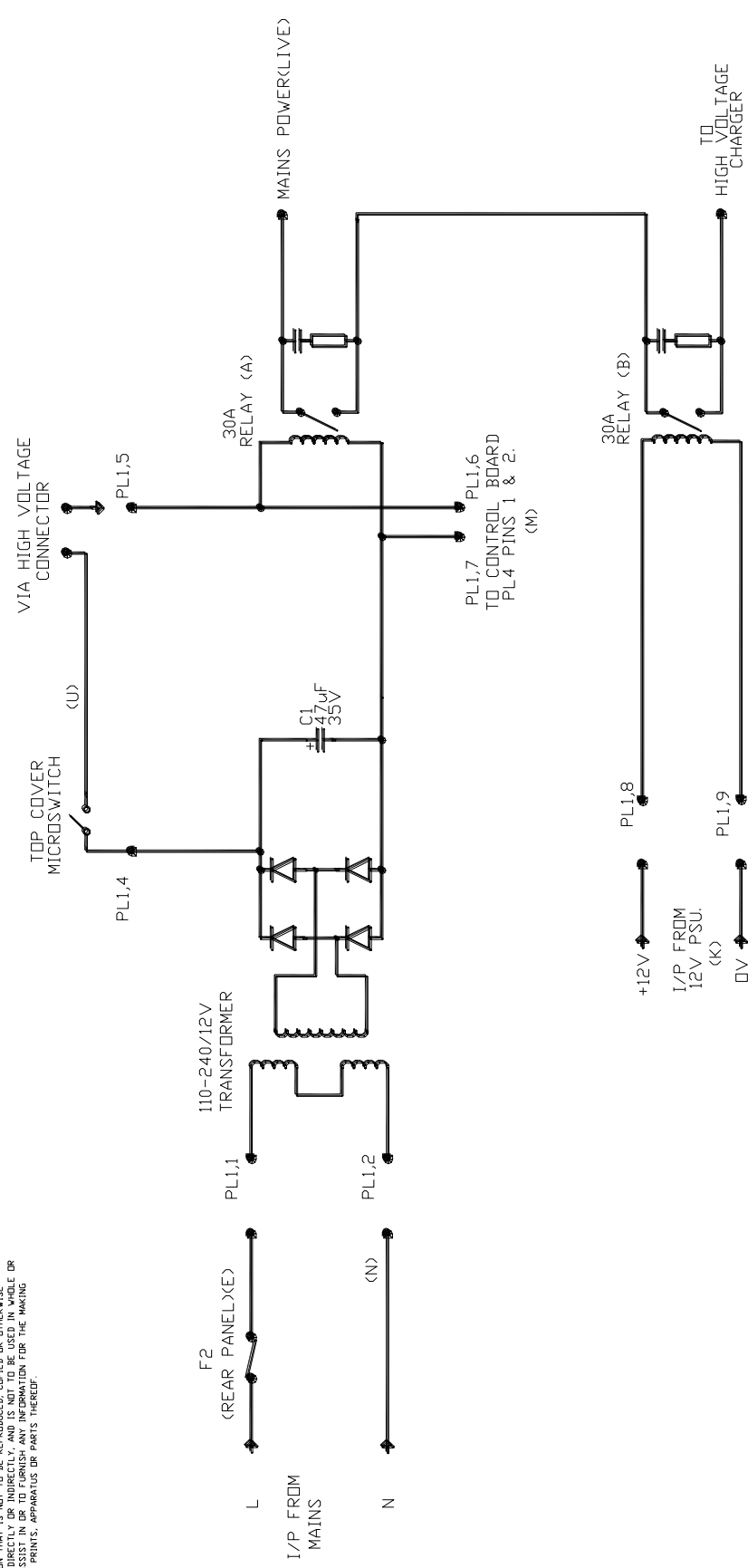

ISSUE	DESCRIPTION	APPD.	DATE	ALL DIMS IN mm	NOT TO SCALE
C	NEW DRAWING No.		15/05/02	MATERIAL	RELAY BOARD.SCH

APPLIED ACOUSTIC ENGINEERING LTD.

DRAWN	DATE
MG	15/05/02
CHECKED	DATE
IRK	15/05/02
APPROVED	DATE
JME	15/05/02

TITLE
CSP1000 RELAY BOARD SCHEMATIC

DRAWING No. CSP-1000-5002/C

APPLIED ACOUSTIC ENGINEERING LTD.
 THIS DRAWING IS LOANED WITHOUT OTHER CONSIDERATION THAN THE AGREEMENT
 AND CONDITION THAT IS NOT TO BE REPRODUCED, COPIED OR OTHERWISE
 DISPOSED OF DIRECTLY OR INDIRECTLY, AND IS NOT TO BE USED IN WHOLE OR
 IN PART FOR THE DESIGN OR CONSTRUCTION OF ANY APPARATUS OR PARTS THEREOF.
 BY DRAWINGS, PRINTS, APPARATUS OR PARTS THEREOF.

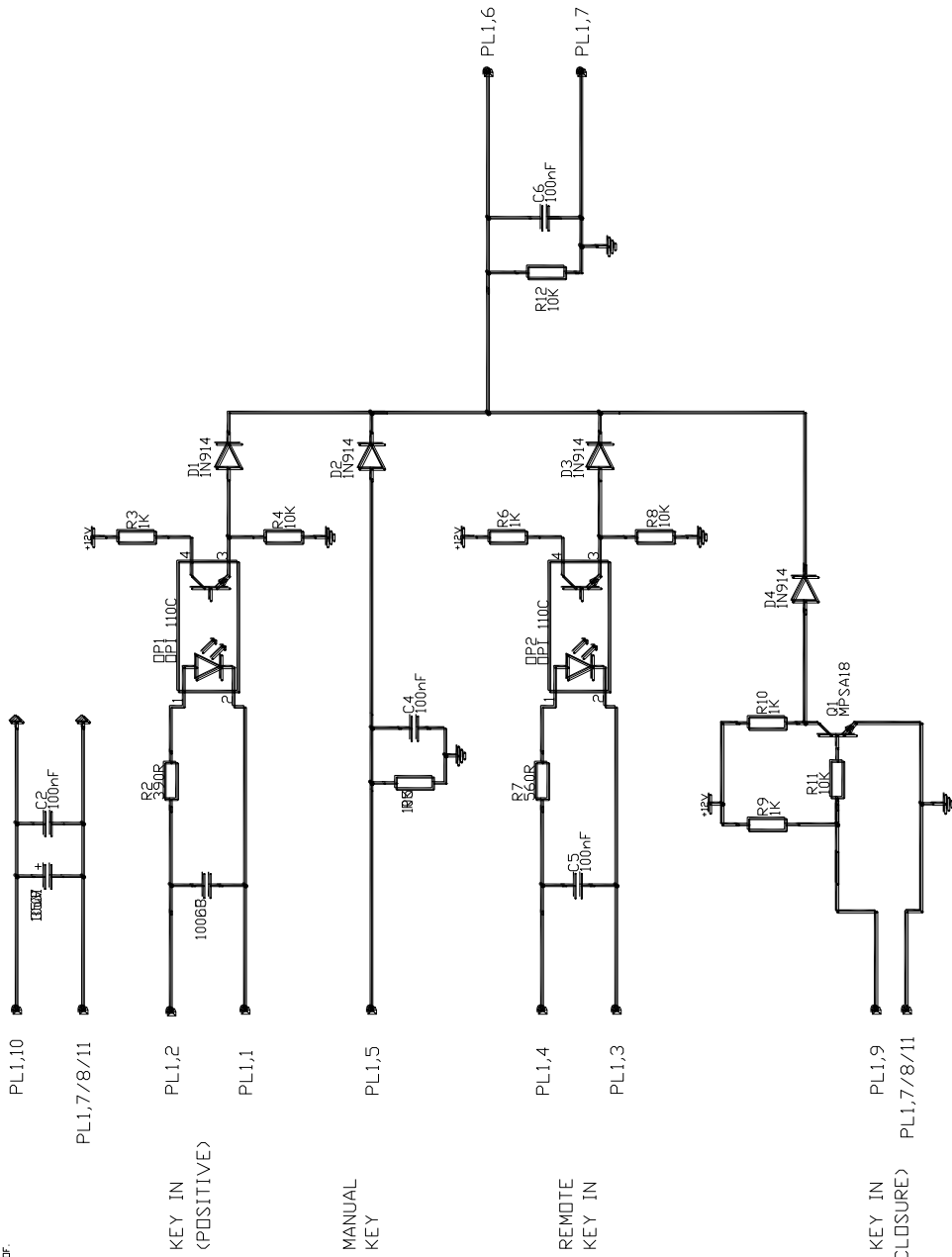

ISSUE	DESCRIPTION	APPD.	DATE	ALL DIMS IN mm	NOT TO SCALE	APPLIED ACOUSTIC ENGINEERING LTD.		DRAWN	MG	DATE	15/05/02	TITLE	CSP1000 KEY BOARD SCHEMATIC
				MATERIAL				CHECKED	IRK	DATE	15/05/02		
C	NEW DRAWING No.		15/05/02	FILE NAME	KEY BOARD.SCH			APPROVED	JME	DATE	15/05/02	DRAWING No.	CSP-1000-5003/C

APPLIED ACOUSTIC ENGINEERING LTD.
 THE COMPANY MAKES NO WARRANTY, REPRESENTATION OR STATEMENT OF ANY KIND IN RELATION TO THE ACCURACY OF THE INFORMATION CONTAINED HEREIN, AND ACCEPTS NO LIABILITY FOR ANY ERRORS OR OMISSIONS. THE INFORMATION IS PROVIDED AS IS, WITHOUT WARRANTY OF ANY KIND, EXPRESS OR IMPLIED, INCLUDING BUT NOT LIMITED TO THE WARRANTIES OF MERCHANTABILITY, FITNESS FOR A PARTICULAR PURPOSE AND NONINFRINGEMENT. IN NO EVENT SHALL THE COMPANY BE LIABLE FOR ANY DAMAGES, INCLUDING GENERAL, SPECIAL, INCIDENTAL OR CONSEQUENTIAL DAMAGES, ARISING OUT OF OR IN CONNECTION WITH THE USE OF THE INFORMATION CONTAINED HEREIN.

BEHLKE MODULE INTERFACE
 CSP-1000-5017 PCB

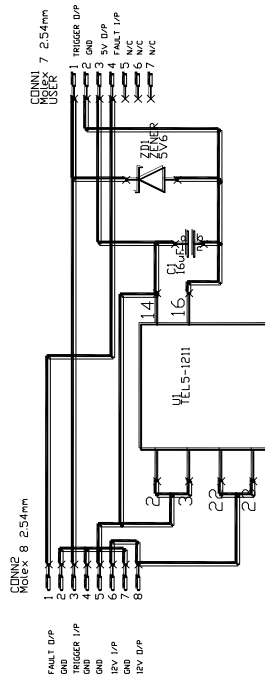

ISSUE	DESCRIPTION	APPD	DATE	ALL DIMS IN mm	NOT TO SCALE	APPLIED ACOUSTIC ENGINEERING LTD.	DRAWN	DATE	TITLE
A	FIRST ISSUE	NM	08/05	MATERIAL			NM	10/10/05	CSP2200 BEHLKE INTERFACE CIRCUIT
				FILE NAME			CHECKED		
				CSP2200_THY_TRIG_A			APPROVED		
									DRAWING No. CSP-1000-5117

APPLIED ACOUSTIC ENGINEERING LTD.
 THE INFORMATION CONTAINED HEREIN IS UNCLASSIFIED EXCEPT WHERE SHOWN OTHERWISE AND IS NOT TO BE REPRODUCED, COPIED, OR OTHERWISE DISSEMINATED IN ANY MANNER WITHOUT THE WRITTEN PERMISSION OF APPLIED ACOUSTIC ENGINEERING LTD. FOR THE ISSUING OF DRAWINGS, PRINTS, APPARATUS OR PARTS THEREOF.

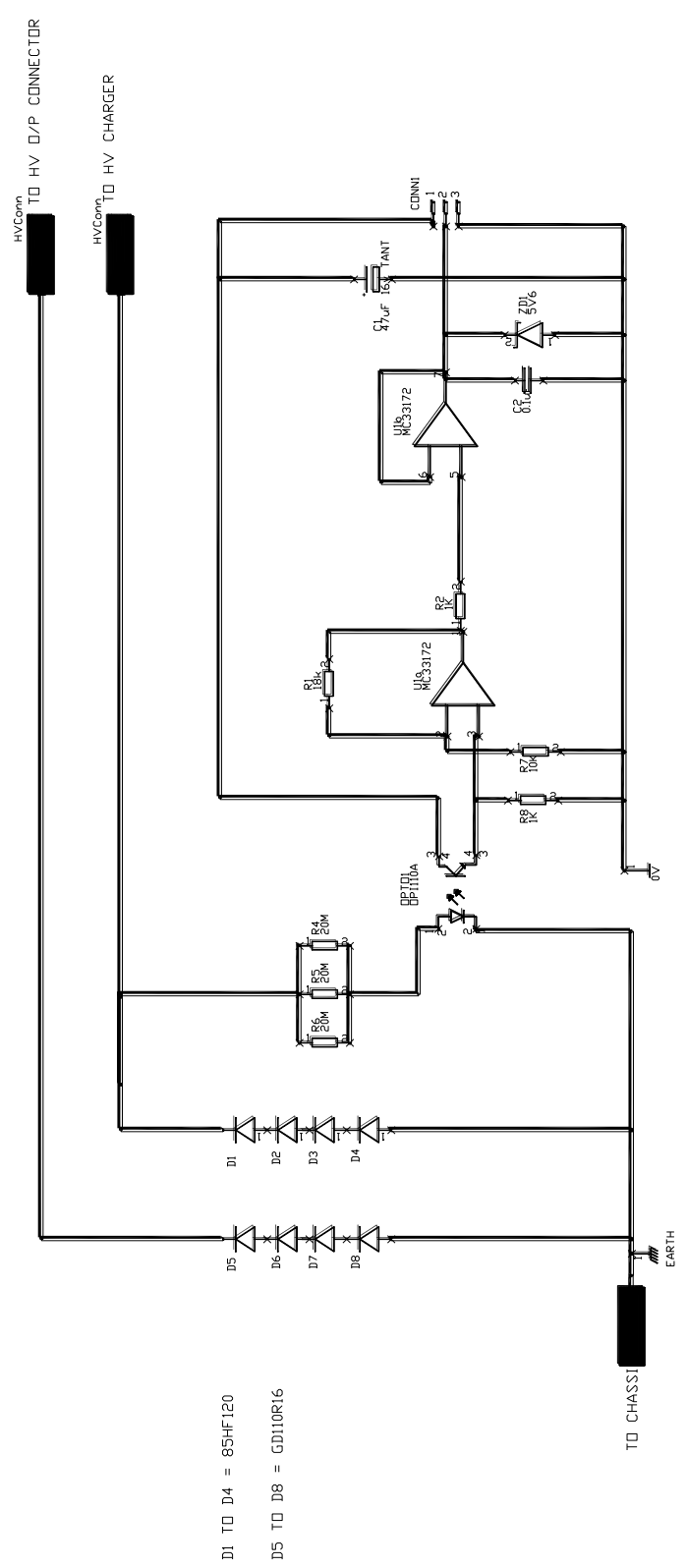

D1 TO D4 = 85HF120
 D5 TO D8 = GD110R16

ISSUE	DESCRIPTION	APPD	DATE	ALL DIMS IN mm	NOT TO SCALE	DRAWN	DATE	TITLE
A	FIRST ISSUE	NM	11/06	MATERIAL		NM	23/11/06	CSP - D HV DIODE BOARD
				FILE NAME		CHECKED	DATE	
				CSP-CSPD-5001-A		APPROVED	DATE	DRAWING No. CSP-CSPD-5101 A

APPLIED ACOUSTIC ENGINEERING LTD.
 THE INFORMATION CONTAINED HEREIN IS UNCLASSIFIED
 AND DISTRIBUTION IS NOT TO BE RESTRICTED, COPIED OR REPRODUCED
 DIRECTLY OR INDIRECTLY, AND IS NOT TO BE USED IN WHOLE OR
 IN PART FOR THE DESIGN OR CONSTRUCTION OF ANY EQUIPMENT OR
 BY DRAWINGS, PRINTS, APPARATUS OR PARTS THEREOF.

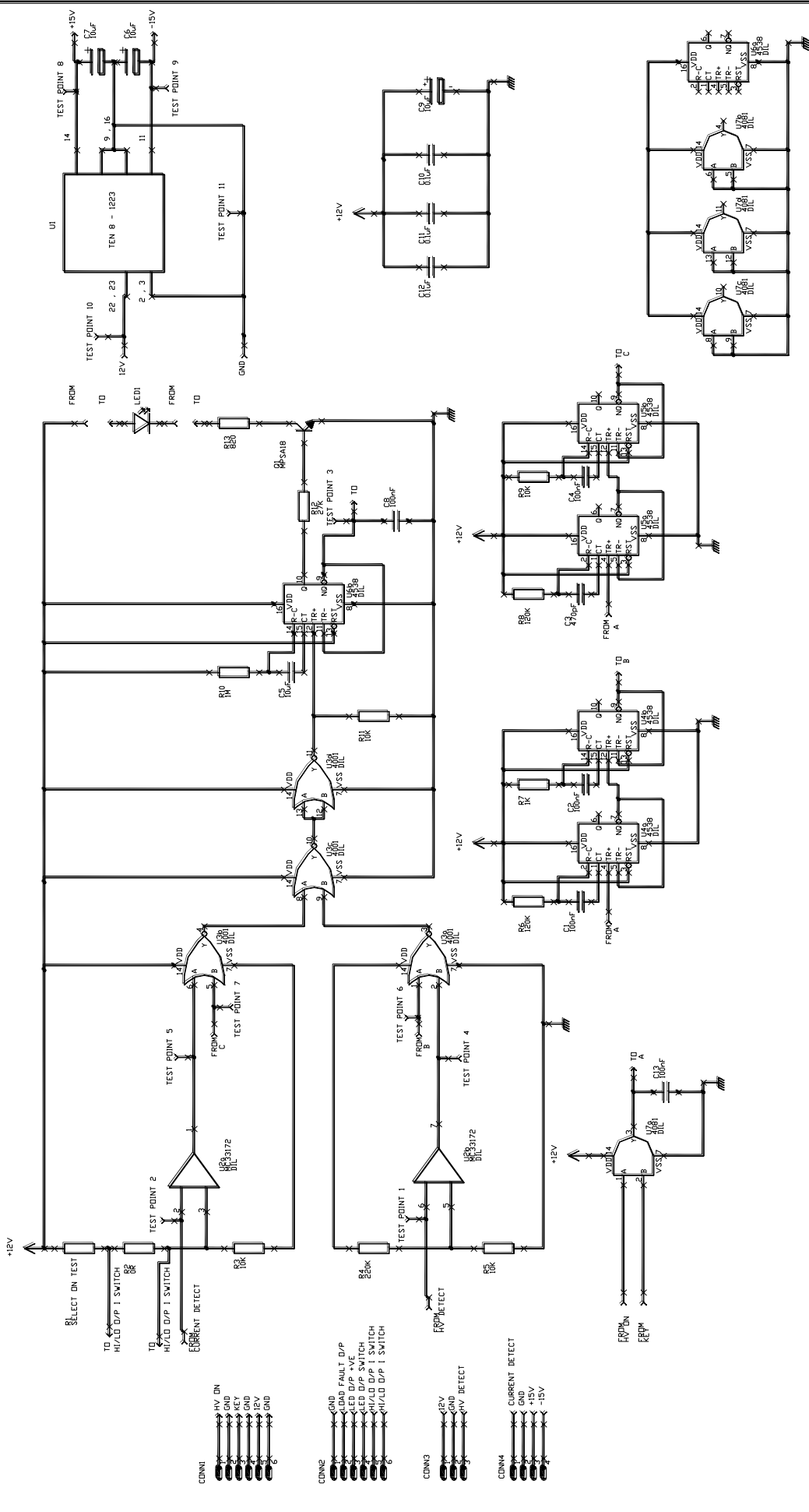

ISSUE	DESCRIPTION	APPD	DATE	ALL DIMS IN mm	NOT TO SCALE	DRAWN	DATE	TITLE
1	PRODUCTION	AD	10/06	MATERIAL		NM	27/11/06	CSP D HV MONITOR BOARD
				FILE NAME	CSP_CSPD 5102 1	APPROVED		DRAWING No.CSP 5102 1

APPLIED ACUSTIC ENGINEERING LTD.
 THIS DRAWING IS LOANED WITHOUT OTHER CONSIDERATION THAN THE AGREEMENT
 AND CONDITION THAT IS NOT TO BE REPRODUCED, COPIED OR OTHERWISE
 DISPOSED OF DIRECTLY OR INDIRECTLY, AND IS NOT TO BE USED IN WHOLE OR
 IN PART FOR THE MANUFACTURE OF ANY APPARATUS OR PARTS THEREOF.
 IF DRAWINGS, PRINTS, APPARATUS OR PARTS THEREOF

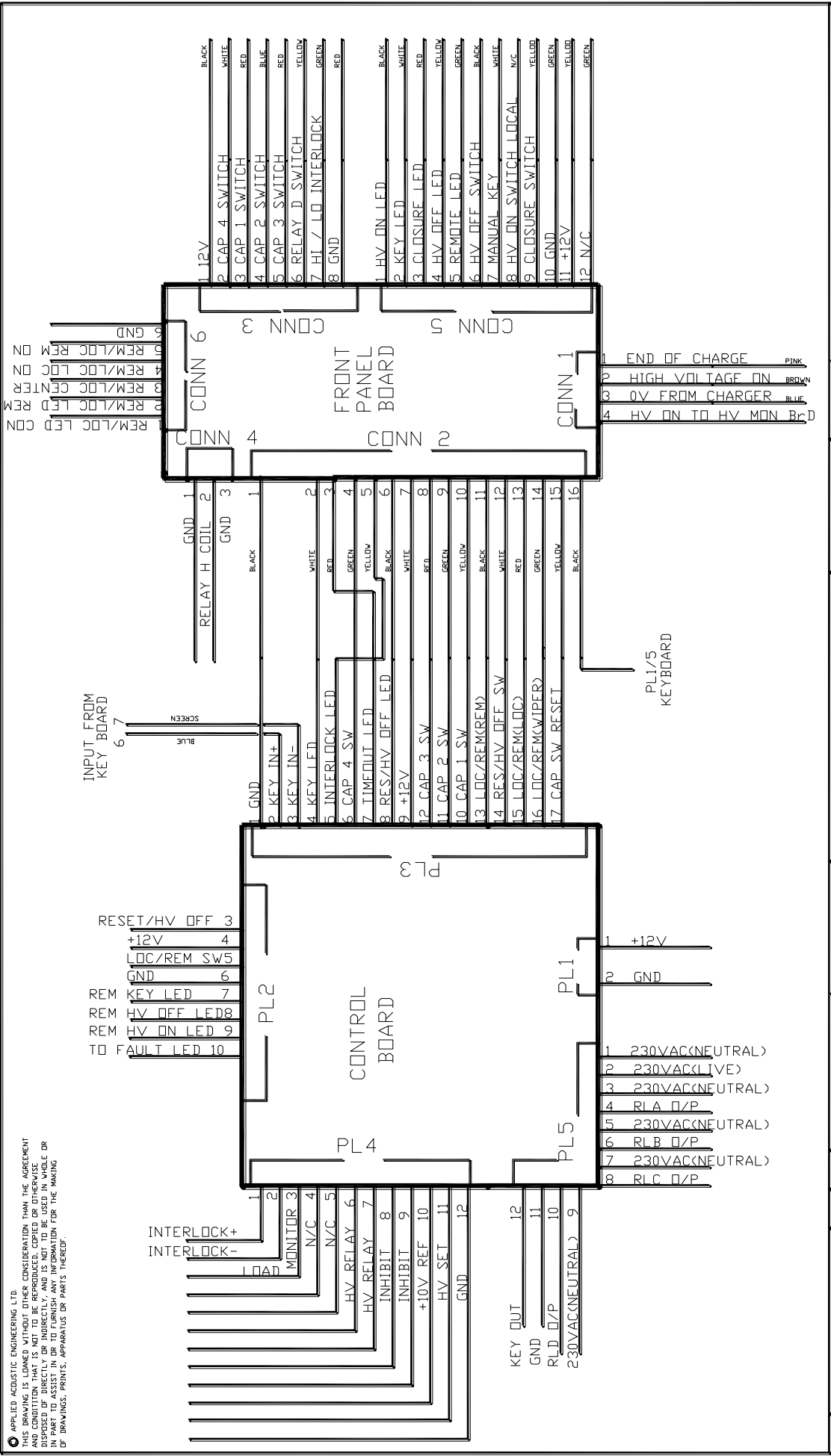

ISSUE	DESCRIPTION	APPD.	DATE	ALL DIMS IN mm	NOT TO SCALE	APPLIED ACUSTIC ENGINEERING LTD.	DRAWN	MG	DATE	15/05/02	TITLE	CSP-D CONTROL ASSEMBLY WIRING DIAGRAM
				MATERIAL			CHECKED	TRK	DATE	15/05/02		
A	CSPD ISSUE		31/02/07	FILE NAME CSPD CONTROL WIRING.SCH			APPROVED	JME	DATE	15/05/02	DRAWING No.	CSP-CSPD-4021/A

DO NOT SCALE REPORT ANY ERRORS IF IN DOUBT ASK PROJECTION THIRD ANGLE

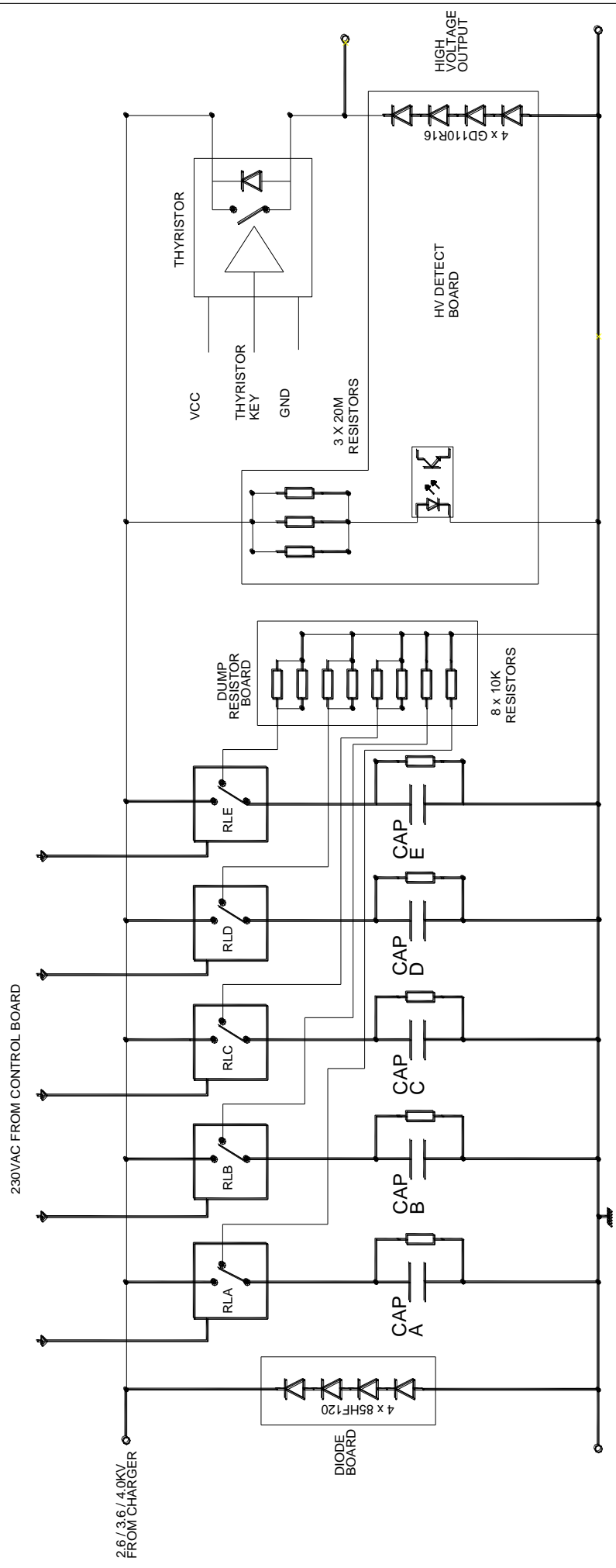

RESISTORS ACROSS CAPACITORS 10MEG-OHM

<p>WARNING</p> <p>THE CONTENTS, INFORMATION AND COPYRIGHT OF THIS DOCUMENT ARE THE SOLE PROPERTY OF APPLIED ACOUSTIC ENGINEERING AND MUST NOT BE USED, PUBLISHED, APPLIED OR COPIED, WITHOUT THE EXPRESS KNOWLEDGE AND WRITTEN PERMISSION OF THE OWNERS.</p>	ISSUE	DESCRIPTION	APPD	DATE	NOTES	
	1	CSP-D NEW ISSUE	APD	12/06	MATERIAL: GEN TOLERANCES: FINISH: MISC: N/A SCALE: N/A	
			DRAWN	NM	DATE	11/12/06
			CHECKED	EB	DATE	11/12/06
			APPROVED		DATE	
			REMOVE ALL SHARP EDGES AND BURRS			DRAWING No: CSP- CSPD-4010/1
			ALL DIMENSIONS IN MILLIMETRES			FILE SAVED AS: CSP-CSPD-HV WIRING

DO NOT SCALE

IF IN DOUBT ASK

REPORT ANY ERRORS

PROJECTION THIRD ANGLE

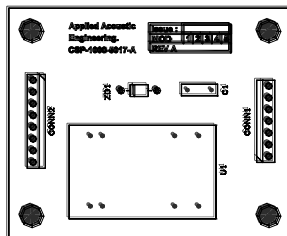
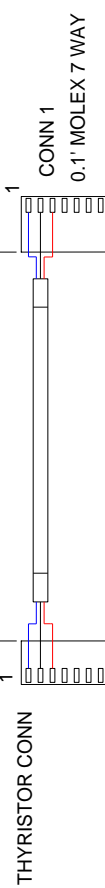
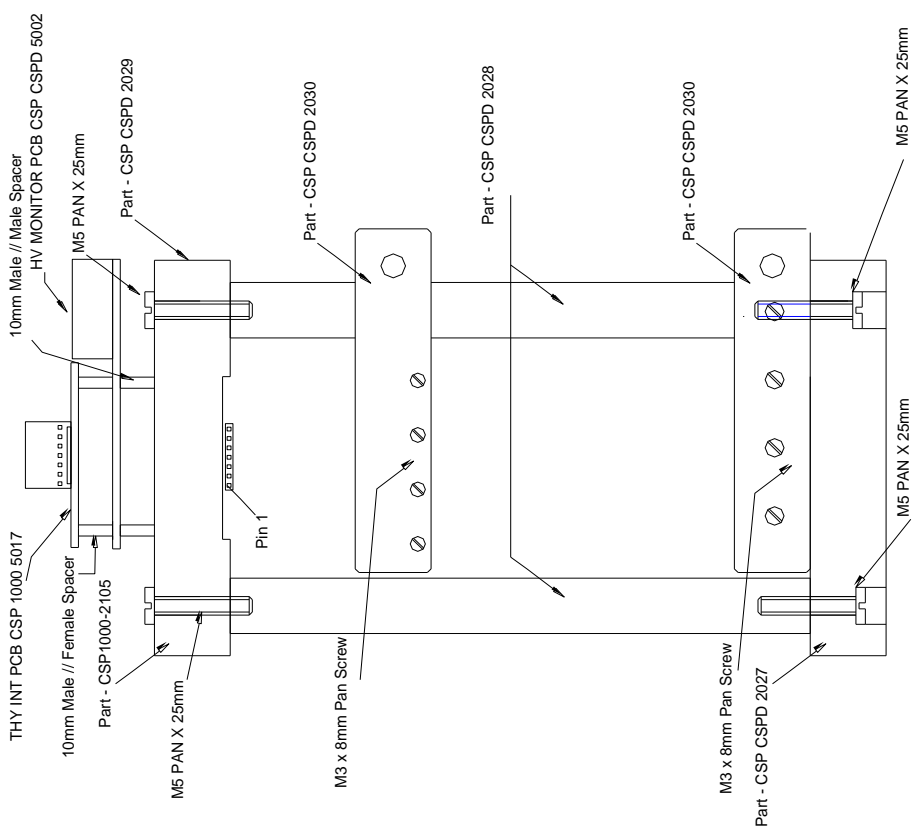

- CONN 1
- 1 TRIGGER
 - 2 GND
 - 3 +5VDC
 - 4 FAULT
 - 5 N/C
 - 6 N/C
 - 7 N/C
- CONN 2
- 1 FAULT O/P } N/C
 - 2 GND
 - 3 TRIGGER I/P } CABLE 'W'
 - 4 GND
 - 5 GND
 - 6 12VDC O/P } CABLE 'Q'
 - 7 GND
 - 8 12VDC } CABLE 'P'

<p>WARNING</p> <p>THE CONTENTS, INFORMATION AND COPYRIGHT OF THIS DOCUMENT ARE THE SOLE PROPERTY OF APPLIED ACOUSTIC ENGINEERING AND MUST NOT BE USED, PUBLISHED, APPLIED OR COPIED, WITHOUT THE EXPRESS KNOWLEDGE AND WRITTEN PERMISSION OF THE OWNERS.</p>	ISSUE	DESCRIPTION	APPD	DATE	NOTES
	1	CSPD First Issue	AD	01/07	MATERIAL: N/A GEN TOLERANCES: N/A FINISH: N/A MISC: SCALE: N/A
	DRAWN	NM	DATE	25/01/07	
	CHECKED	ED	DATE	25/01/07	TITLE: CSP D Thyristor Module Clamp Assembly & Interface
	APPROVED		DATE		
	REMOVE ALL SHARP EDGES AND BURRS				DRAWING No: CSP CSPD 1019/1
	ALL DIMENSIONS IN MILLIMETRES				FILE SAVED AS: CSPD THY CLAMP ASY

DO NOT SCALE

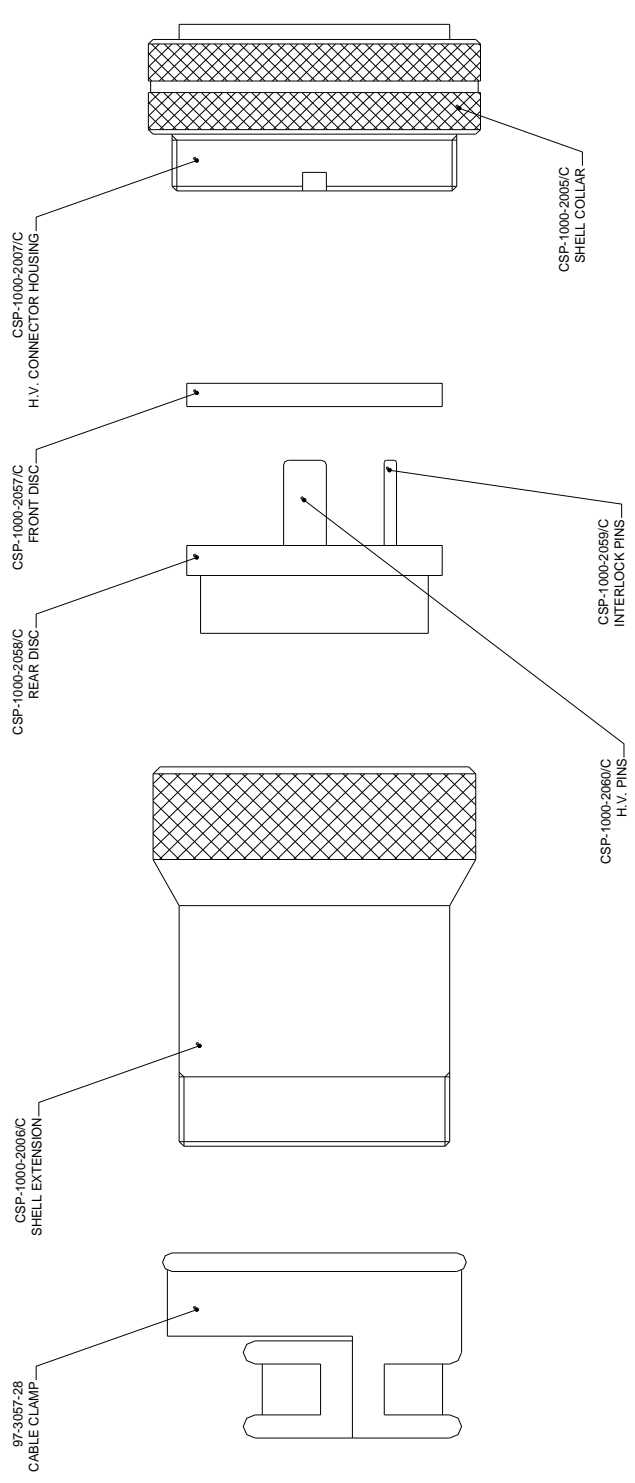
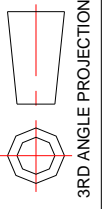

<p>WARNING THE CONTENTS, INFORMATION AND COPYRIGHT OF THIS DOCUMENT ARE THE SOLE PROPERTY OF APPLIED ACOUSTIC ENGINEERING AND MUST NOT BE USED, PUBLISHED, APPLIED OR COPIED, WITHOUT THE EXPRESS KNOWLEDGE AND WRITTEN PERMISSION OF THE OWNERS.</p>	ISSUE	DESCRIPTION	APPD	DATE	NOTES	DRAWN	NM	DATE	19/01/07
	1	CSPD ISSUE	AD	1/07		CHECKED	EB	DATE	19/01/07
						APPROVED		DATE	
						REMOVE ALL SHARP EDGES AND BURRS			
						ALL DIMENSIONS IN MILLIMETRES			
						DO NOT SCALE			
						TITLE: CSP-D H.V. PLUG COMPONENT ASSEMBLY			
						DRAWING No: CSP-CSPD-1011/1			
						FILE SAVED AS: HV PLUG ASSY1			

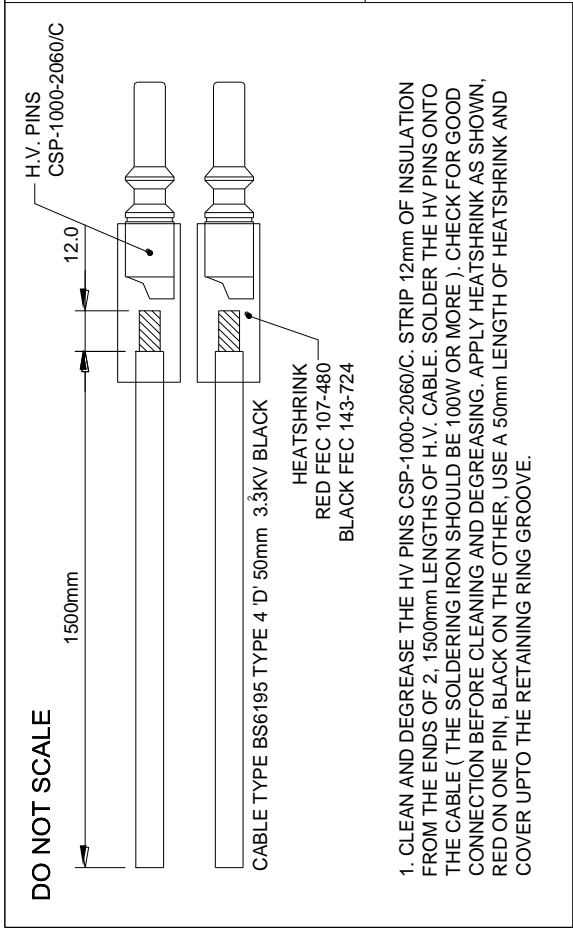

1. CLEAN AND DEGREASE THE HV PINS CSP-1000-2060/C. STRIP 12mm OF INSULATION FROM THE ENDS OF 2, 1500mm LENGTHS OF H.V. CABLE. SOLDER THE HV PINS ONTO THE CABLE (THE SOLDERING IRON SHOULD BE 100W OR MORE). CHECK FOR GOOD CONNECTION BEFORE CLEANING AND DEGREASING. APPLY HEATSHRINK AS SHOWN, RED ON ONE PIN, BLACK ON THE OTHER, USE A 50mm LENGTH OF HEATSHRINK AND COVER UP TO THE RETAINING RING GROOVE.

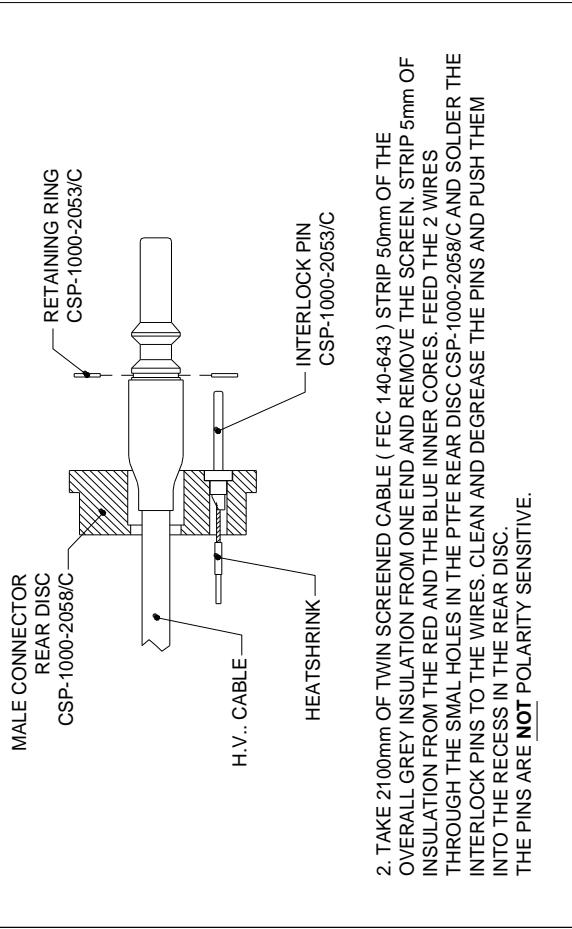

2. TAKE 2100mm OF TWIN SCREENED CABLE (FEC 140-643) STRIP 50mm OF THE OVERALL GREY INSULATION FROM ONE END AND REMOVE THE SCREEN. STRIP 5mm OF INSULATION FROM THE RED AND THE BLUE INNER CORES. FEED THE 2 WIRES THROUGH THE SMALL HOLES IN THE PTFE REAR DISC CSP-1000-2058/C AND SOLDER THE INTERLOCK PINS TO THE WIRES. CLEAN AND DEGREASE THE PINS AND PUSH THEM INTO THE RECESS IN THE REAR DISC. THE PINS ARE **NOT** POLARITY SENSITIVE.

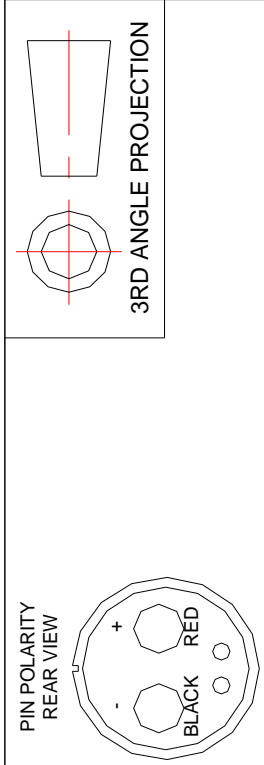

3. FIT THE RETAINING RINGS (CSP-1000-2053/C) ON THE H.V. PINS. PUSH THE H.V. PINS BACK INTO THE RECESSES IN THE REAR DISC ENSURING CORRECT POLARITY.

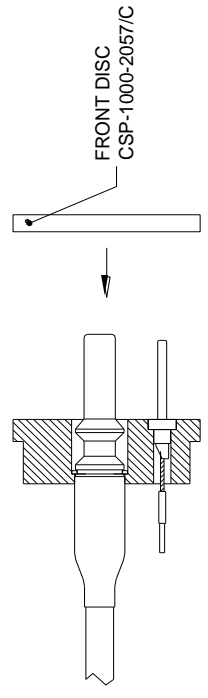

4. PUSH THE PTFE FRONT DISC (CSP-1000-2057/C) OVER THE ASSEMBLY AS SHOWN. REFER TO DRAWING CSP-1000-3005/C AND ASSEMBLE THE CONNECTOR AS FOLLOWS:

- PUSH THE 2 PTFE DISCS INTO THE HOUSING
- FEED THE LOCKING COLLAR OVER THE HOUSING SO THAT IT ROTATES FREELY
- SECURE THE PTFE INSERTS INTO THE HOUSING USING CIRCLIP (NIFCSB-055)
- SCREW THE EXTENSION SHELL ONTO THE HOUSING
- SCREW THE CABLE CLAMP ONTO THE EXTENSION SHELL AND SECURE THE CABLE WITH THE CABLE CLAMP.

5. USING AN 8KV MEGGER PERFORM THE FOLLOWING INSULATION TESTS:

- POSITIVE AND NEGATIVE HIGH VOLTAGE PINS
- POSITIVE HIGH VOLTAGE PIN TO CASE
- NEGATIVE HIGH VOLTAGE PIN TO CASE
- POSITIVE HIGH VOLTAGE PIN TO BOTH INTERLOCK PINS
- NEGATIVE HIGH VOLTAGE PIN TO BOTH INTERLOCK PINS

NOTE: BECAUSE OF THE HIGH VOLTAGE INVOLVED, ONLY EXPERIENCED PERSONNEL MUST CARRY OUT THE ABOVE TEST. EXERCISE EXTREME CAUTION, KEEPING CLEAR FROM THE ASSEMBLY WHEN TESTING.

6. SEE DRAWING CSP-1000-3004/C FOR DETAILS OF JUNCTION BOX END OF THE CABLE.

ISSUE	DESCRIPTION	APPD	DATE	NOTES
1	CSPD ISSUE	AD	01/07	<p>MATERIALS: SEE DRAWINGS</p> <p>GEN TOLERANCES: ±2mm</p> <p>FINISH: N/A</p> <p>OTHER: SCALE 1:2</p>
<p>WARNING</p> <p>THE CONTENTS, INFORMATION AND COPYRIGHT OF THIS DOCUMENT ARE THE SOLE PROPERTY OF APPLIED ACOUSTIC ENGINEERING AND MUST NOT BE USED, PUBLISHED, APPLIED OR COPIED WITHOUT THE EXPRESS KNOWLEDGE AND WRITTEN PERMISSION OF THE OWNERS.</p>				
DRAWN		NM	DATE	19/01/07
CHECKED		EB	DATE	19/01/07
APPROVED			DATE	
REMOVE ALL SHARP EDGES AND BURRS				
ALL DIMENSIONS IN MILLIMETRES				
DO NOT SCALE				
DRAWING No: CSP-CSPD-1012/1				FILE SAVED AS: HV PLUG ASSY2.DWG

DO NOT SCALE

ASSEMBLY NOTES

1. STRIP INSULATION BACK 12mm
2. SOLDER RING CRIMP TO CABLE
3. CLEAN RING CRIMP THOROUGHLY
4. COVER THE CRIMP WITH HEATSHRINK (RED OR BLACK)
5. SPIRAL WRAP AROUND CABLES TO FINISH ASSEMBLY

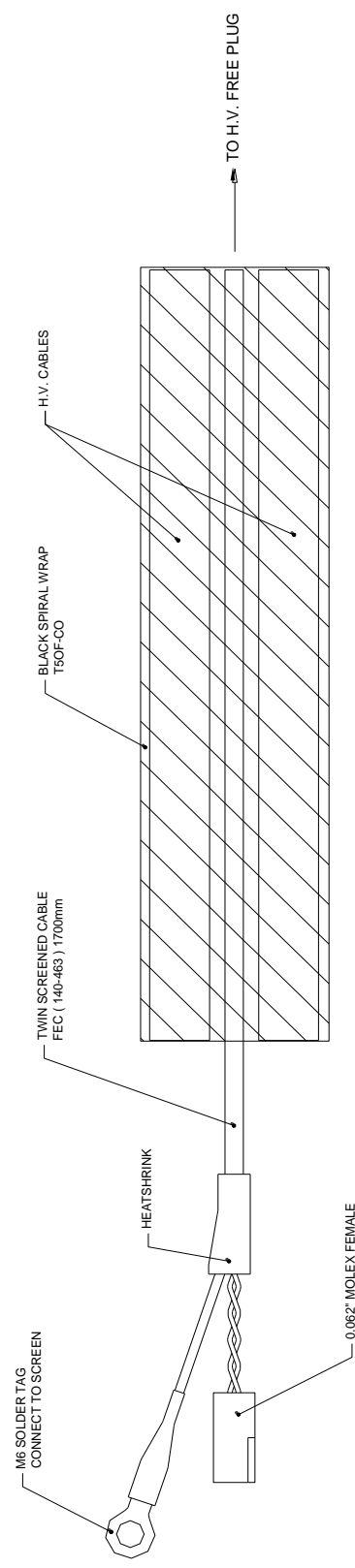
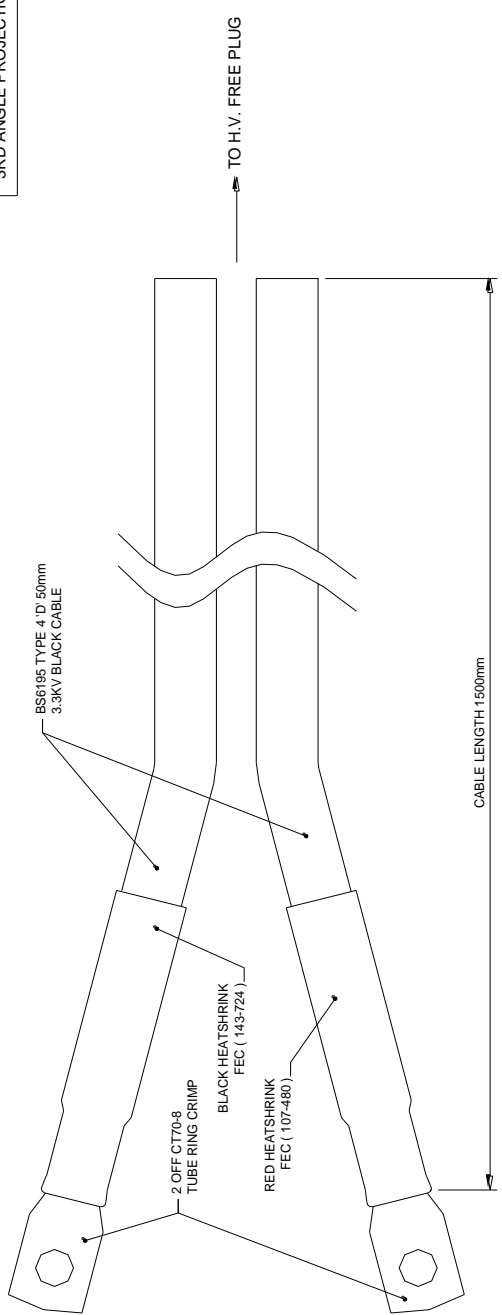
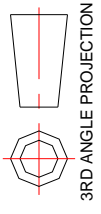

THIS DRAWING IS TO BE USED AS PART OF THE H.V. PLUG ASSEMBLY - CSP-1000-3007/C THE ASSEMBLY OF THE OTHER END OF THE CABLE (H.V. PLUG) MUST BE COMPLETED BEFORE STARTING ON THIS END OF THE CABLE.

ISSUE	DESCRIPTION	APPD.	DATE	NOTES	DRAWN	NM	DATE
1	WARNING THE CONTENTS, INFORMATION AND COPYRIGHT OF THIS DOCUMENT ARE THE SOLE PROPERTY OF APPLIED ACOUSTIC ENGINEERING AND MUST NOT BE USED, PUBLISHED, APPLIED OR COPIED, WITHOUT THE EXPRESS KNOWLEDGE AND WRITTEN PERMISSION OF THE OWNERS.			MATERIALS: SEE DRAWING GEN TOLERANCES: ±2mm FINISH: N/A OTHER: SCALE 1: 1			22/01/07
					CHECKED	IRK	22/01/07
					APPROVED	DATE	
					REMOVE ALL SHARP EDGES AND BURRS		
					ALL DIMENSIONS IN MILLIMETRES		
					DO NOT SCALE		
					DRAWING No: CSP-CSPD-3002/1		
					FILE SAVED AS: JBOX HV CABLE		

DO NOT SCALE

CONNECTOR WIRING DETAILS

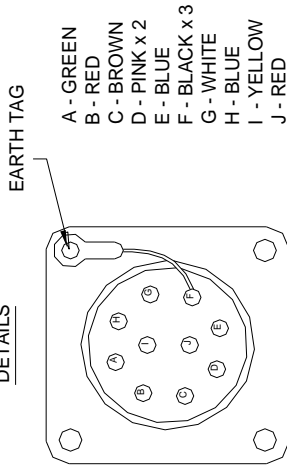

REAR VIEW

- 1 x DIE CAST BOX (GREY)
- 1 x BNC CONNECTOR
- 2 x SPDT SWITCH SOCKET
- 2 x SWITCH BODY
- 1 x SCREEN SQUARE (YELLOW)
- 1 x SCREEN SQUARE (RED)
- 1 x 12V LED (YELLOW)
- 1 x 12V LED (RED)
- 1 x 5mm LED (YELLOW)
- 1 x 5mm LED (RED)
- 2 x RESISTOR 180R 1/4W
- 2 x RESISTOR 820R 1/4W
- 1 x RESISTOR 10K 1/4W
- 2 x CAPACITOR 0.1uF CERAMIC
- 1 x AMPHENOL CONNECTOR 10 PIN MALE
- 4 x M3 x 16mm PAN HEAD
- 4 x M3 WASHERS
- 4 x M3 SHAKEPROOF WASHERS
- 4 x M3 NYLOC NUTS

KEY/FAULT LEDS

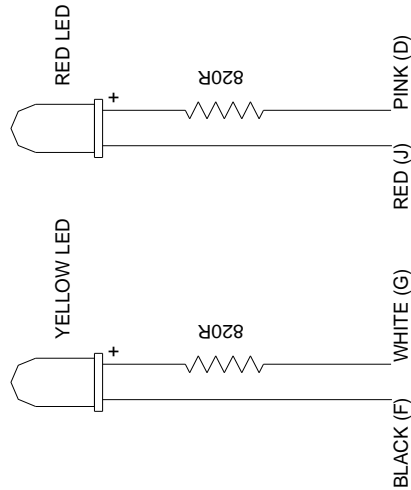

HIGH VOLTAGE ON

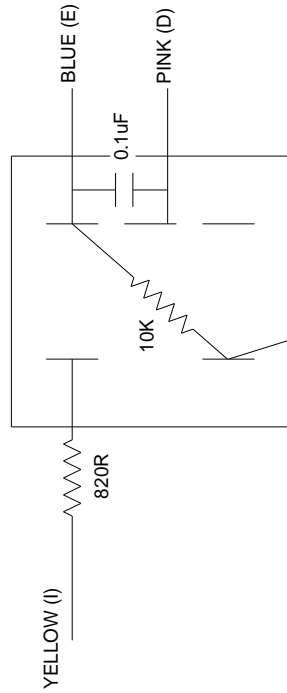

HIGH VOLTAGE OFF

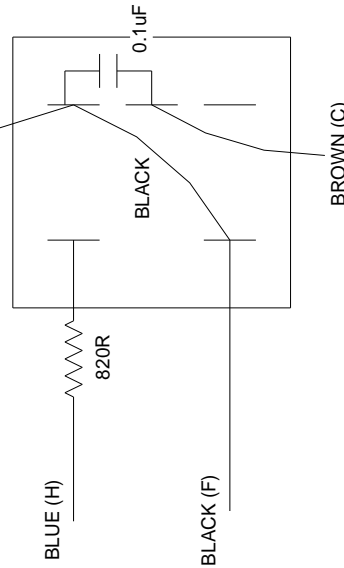

BNC CONNECTOR

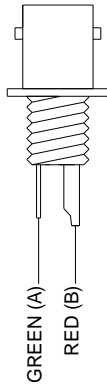

ISSUE	DESCRIPTION	APPD	DATE	NOTES	DRAWN	TDA	DATE
				MATERIALS: SEE DRAWING			08/07/02
				GEN TOLERANCES: N/A	CHECKED	IRK	08/07/02
				FINISH: N/A	APPROVED	JME	08/07/02
				OTHER: SEE DRAWING	REMOVE ALL SHARP EDGES AND BURRS		
					ALL DIMENSIONS IN MILLIMETRES		
C	PRODUCTION	JME	07/02		DO NOT SCALE		

WARNING
THE CONTENTS, INFORMATION AND COPYRIGHT OF THIS DOCUMENT ARE THE SOLE PROPERTY OF APPLIED ACOUSTIC ENGINEERING AND MUST NOT BE USED, PUBLISHED, APPLIED OR COPIED WITHOUT THE EXPRESS KNOWLEDGE AND WRITTEN PERMISSION OF THE OWNERS.

FILE SAVED AS: 1000 RBOX WIR.DWG
DRAWING No: CSP-1000-4012/C
TITLE: CSP1000 REMOTE BOX WIRING DETAILS NEW SWITCHES A16-1

APPLIED ACOUSTIC ENGINEERING, LTD.
 THIS DRAWING IS LOANED WITHOUT OTHER CONSIDERATION THAN THE AGREEMENT
 AND CONDITION THAT IS NOT TO BE REPRODUCED, COPIED OR OTHERWISE
 DISPOSED OF DIRECTLY OR INDIRECTLY, AND IS NOT TO BE USED IN WHOLE OR
 IN PART TO ASSIST IN OR TO FURNISH ANY INFORMATION FOR THE MAKING
 OF DRAWINGS, PRINTS, APPARATUS OR PARTS THEREOF.

CSP FRONT PANEL

REMOTE BOX

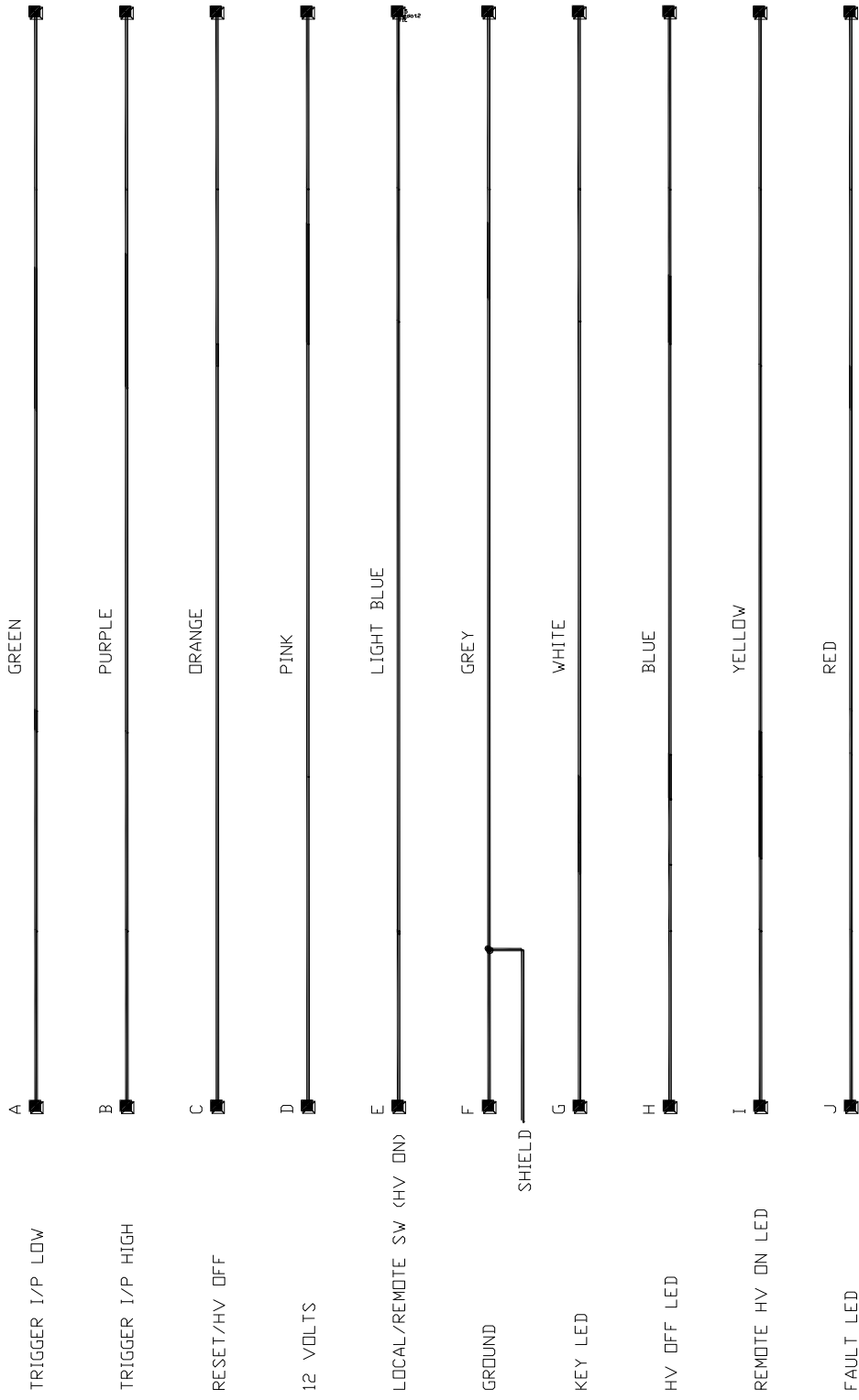

10 WAY PLUG (18-1P)

10 WAY SOCKET (18-1S)

ISSUE	DESCRIPTION	APPD.	DATE	ALL DIMS IN mm	NOT TO SCALE	APPLIED ACOUSTIC ENGINEERING LTD.	DRAWN MG	DATE	TITLE
								CHECKED TRK	
C	NEW DRAWING No. SWAP SHIELD END		15/05/02	FILE NAME REMOTE CABLE.SCH			APPROVED JME	DATE 15/05/02	DRAWING No. CSP-1000-4007/C



APPLIED ACOUSTICS

Underwater Technology

Applied Acoustic Engineering Ltd
Marine House
Marine Park
Gapton Hall Road
Great Yarmouth
NR31 0NL UK

Phone: +44 (0) 1493 440355
Fax: +44 (0) 1493 440720

E-mail techsupport@appliedacoustics.com
www.appliedacoustics.com